

lubrication systems



HYDRA

High performance hydraulic pump
for Lubrication systems



TABLE OF CONTENTS

REV07062021

Description	3	System structure	5
Features and benefits	3	Order	6
Applications	3	Components	7
Technical Data	4	Accessories	11
Technical data	4	Dimensions	13
Hydraulic data	4		
Electrical Data	4		
Lubricant Level control	4		
Release valve	4		



All ILC products must only be used for their intended purposes, as specified in this brochure and in all instructions. If the product is supplied together with user instructions, the user is required to read them and comply with them. Not all lubricants are suitable for centralised lubrication systems. ILC lubrication systems or relative components cannot be used together with gas, liquid gas, pressurised gas in solution and liquids with vapour pressure exceeding normal atmospheric pressure (1013 bar) by more than 0.5 bar, maximum temperature permitted. Any type of dangerous materials, namely those classified as such by European Community Directive (EC) 67/548/EEC, Article 2 (2), can only be used in ILC centralised lubrication systems or relative components upon consultation with ILC and after having received written approval from the company.

Features and benefits

The ILC Maximeter system has been designed to lubricate heavy duty and large machinery. The system consists of a Hydraulic pump (Hydra) which supplies the lubricant to a Single-line system equipped with CX, CM or CL valves. Each metering device supplies a single point and we can adjust its flow rate with precision.

The Maximeter systems have several advantages.

High performance pump

The Maximeter systems supply adjustable quantities of both grease and oil. Operation is not affected by changes in the lubricant temperature or viscosity. The metering devices can be located at great distances from the pump tanks.

Resistance

The Maximeter systems are suitable for work in difficult conditions, particular environments and temperatures below or above the standard.

Easy Installation

The Maximeter systems are simple to manage, install and maintain.

External Adjustment

The metering valves are externally adjustable without the use of special tools. Each point to be lubricated will receive the right amount of lubricant.

Visual Indicators

Each metering valve is equipped with an indicator which gives a visual indication of its correct operation. Troubleshooting is quick.

Simplified Maintenance

The replacement of the metering valves is quick and simple. It is not necessary to remove the line power supply connections or act on the adjacent metering devices: the replacement can be made between work cycles, without leakage of lubricant.

Applications



Front wheel loaders



Mining Trucks

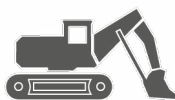

Digging buckets



Drag excavators



Bucket Excavator

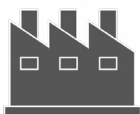

Cement factories



Shredders

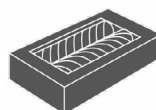

Mining Dimensioners

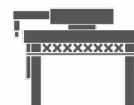

Port Loaders



Slurry Pumps

Technical data

Operating principle	Hydraulic Pump
Metering	Adjustable from 120 to 400 cc / min
Transmission ratio	10:1 with inlet pressure from 20 to 25 bar and Flow rate 10-18 l/1' 11:1 with inlet pressure from 26 to 32 bar and Flow rate 18-28 l/1'
Maximum Operating Pressure	241 bar [3500psi]
Safety Valve	Set to 250 bar ±10%
Lubricants	NLGI Grease from 00 to 2
Outlets	1
Working temperature	from -30 to +65 °C
Tank capacity	27 - 41 Kg
Materials	elastomer, steel, aluminium, bronze, copper, brass
Outlet connections	3/8" BSP F
Assembly position	Vertical

Hydraulic data

Inlet Pressure	max. 200 bar
Inlet Operating Pressure	from 20 to 32 bar
Hydraulic Inlet Pressure	min. 5 max. 28 l/1'
Hydraulic Fluid Temperature	max. +90 °C;
Inlet and return hydraulic connection	BSP 1/4"

Electrical Data

Lubricant Level control

Level Switch	Laser Sensor, Class 1, 2 signals
Protection	IP-67 IO-Link
Connection	Connector M12x1
Power supply	10-30 V DC
Signal Output	PNP
Fixing	M18x1

Release valve

Nomenclature	3/2 Ways	Input Port	1/2" BSP
Supply voltage	24 V DC	Output Port	1/2" BSP
Power	26 W	Release Port	3/8" BSP
Absorption	1.1 A	Max Pressure	400 Bar (5802 Psi)
Connector	Din 43650-A 3P		

Hydraulic Diagram

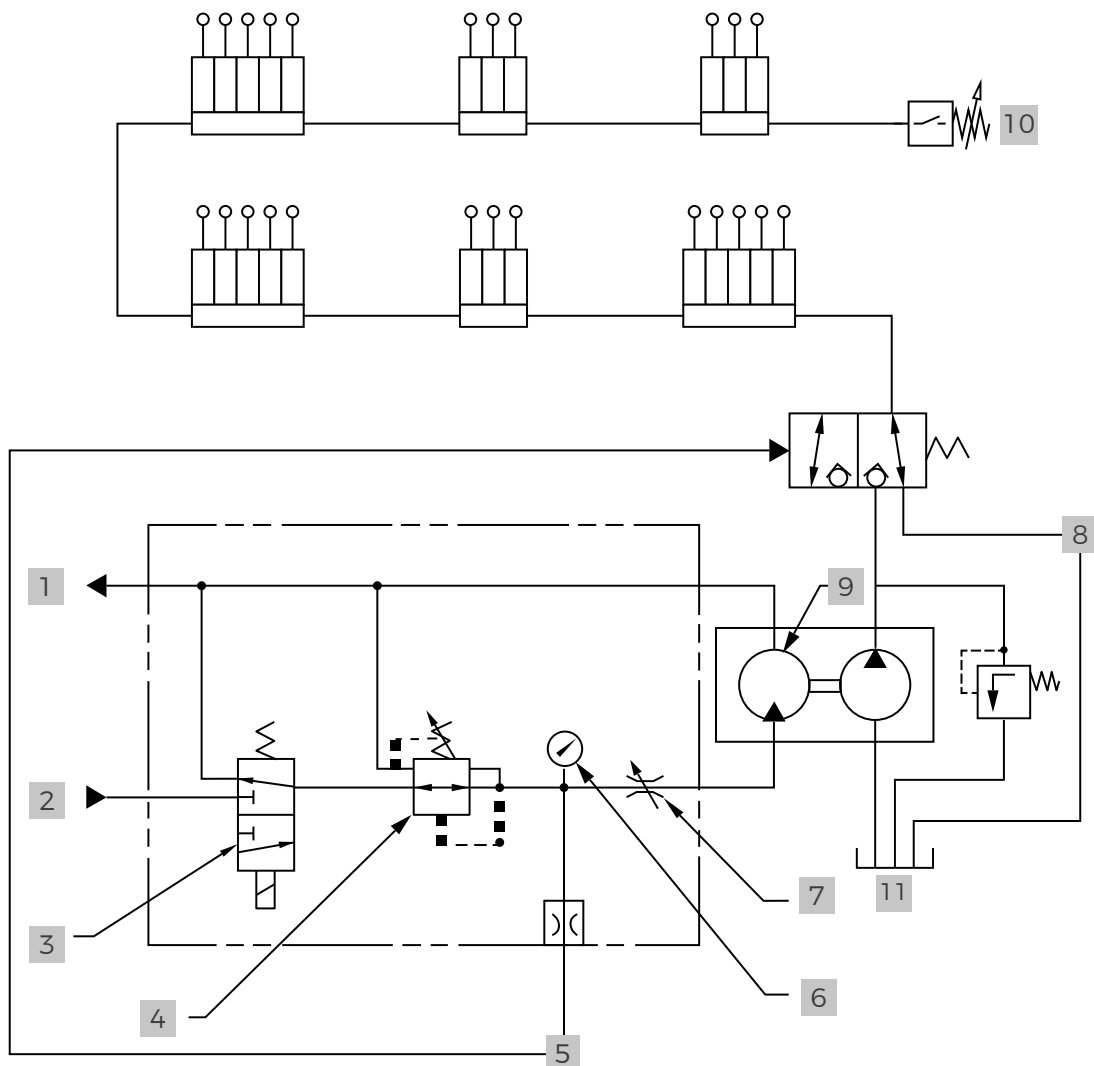

- | | | | |
|---|--------------------------|----|-----------------------------|
| 1 | Return to hydraulic line | 7 | Flow Rate Adjustment Valve |
| 2 | Hydraulic Oil Inlet | 8 | Lubricant outlet |
| 3 | Solenoid valve | 9 | Hydraulic Motor |
| 4 | Pressure Reducing Valve | 10 | End of line pressure switch |
| 5 | Release Valve | 11 | Lubricant Tank |
| 6 | Pressure gauge | | |

Order code configurator

| 86 | . | 27 | . | 1 | . | 1 | . | X | . | X | . | X |

A
B
C
D
E
F



A (Pump)		B (Release Module)		C (Tank) **	
27 kg	27	Yes	1	Cover Only	1
41 kg	41	No	X	Complete Tank	2
180 Kg	18	Valve Only Max Pressure	2*	Without a tank	X

**for progressive and double line systems*

***The complete tank is not available for the 180 kg model*

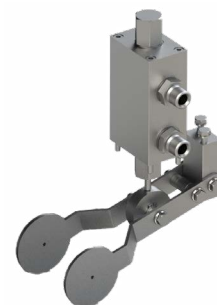

D (Presser Disc)		E (Electric Level Sensor)***		F (Loading Kit)***	
Yes	1	Yes	1	Yes	1
No	X	No	X	No	X

****requires presser disc (D)*

****requires presser disc (D)*

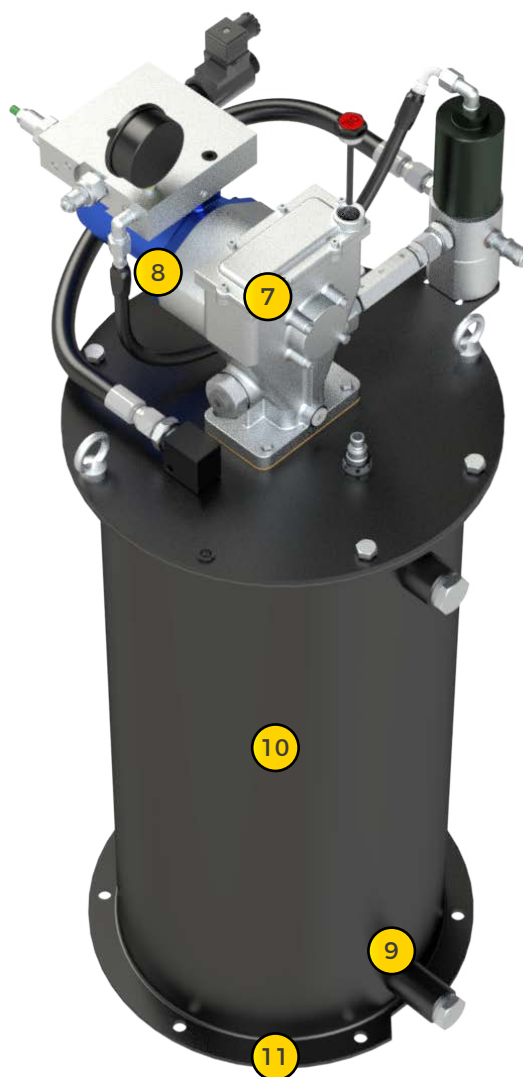
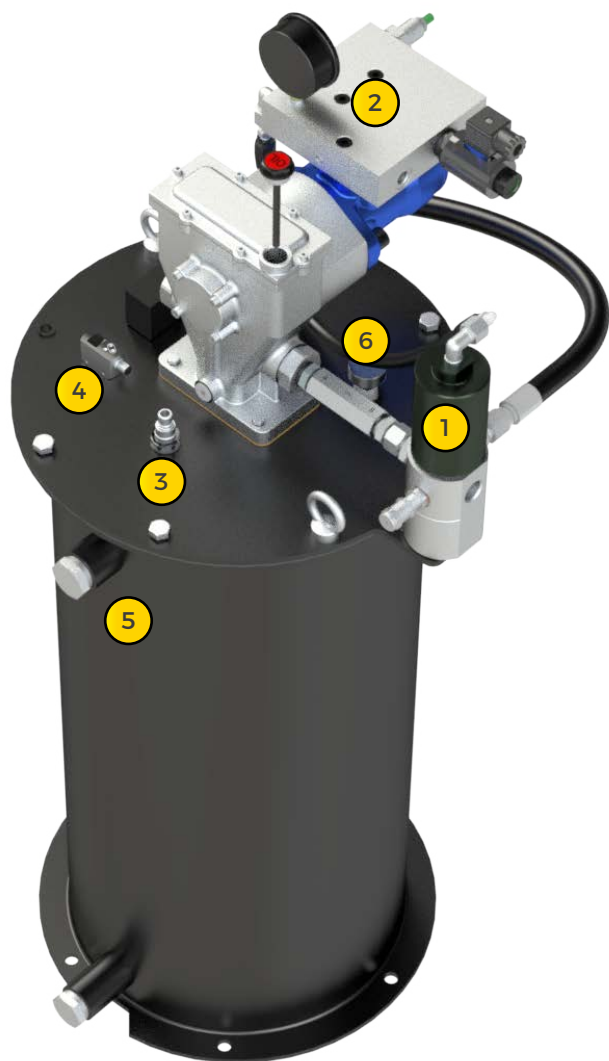

1 Release Valve

2 Control Unit

3 Overflow Connection

4 Minimum Level Control

5 Vent Plug

6 Tank vent

7 Pump body

8 Hydraulic Motor

9 Filling Connection

10 Tank

11 Fixing Plate

Pump

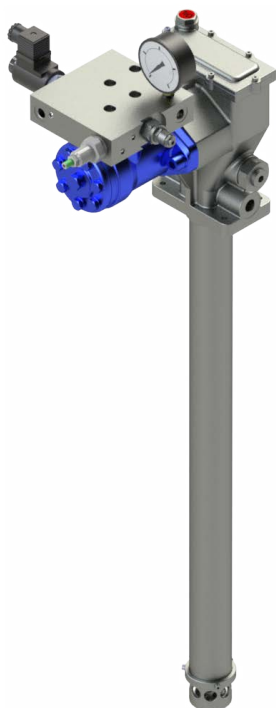

27/41 Kg



180/200 kg

With Pump Control

Dimensions	Part No.
27 Kg	86.27.X.X.X.X.X
41 Kg	86.41.X.X.X.X.X
180 Kg	86.18.X.X.X.X.X

Without Pump Control

Dimensions	Part No.
27 Kg	A72.079504
41 Kg	A72.079505
180 Kg	A72.079515

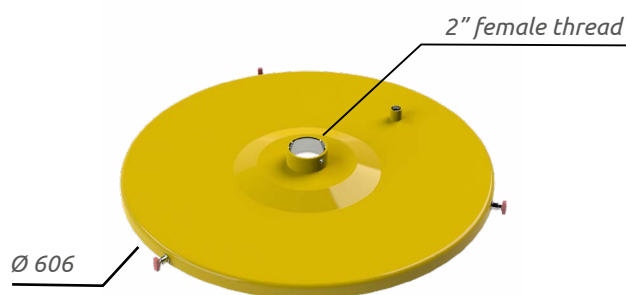

The 27 Kg and 41 Kg pumps are supplied with ILC tank of respective capacity.

Whereas, the 180 kg pump is designed for installation in standard 180 kg grease drums with 2" F perforated cover.

To simplify assembly (where the complete supply of drum cover is required) ILC provides an adapter plate that allows you to use any cover.

pump assembly does not require any drilling or mechanical machining of the drum cover. Only if the electric level is required, is it necessary to make a hole that allows reading the presser disc movement.

The pump is supplied with screws and gasket.

Release Valve



The release valve is required to feed the single-line systems equipped with CX, CL or CM valves. It releases the system pressure so that the metering devices are ready for a new cycle and protects the system from any overpressure. It is supplied complete with Flex pipes for the pump and the tank return port.

Part No.

A70.093786

Control Unit

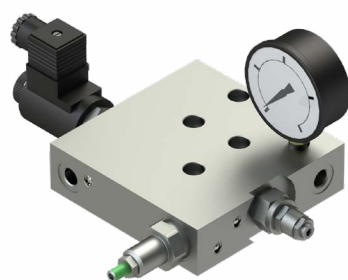

A Control manifold is integrated with the motor. The oil inlet pressure must never exceed 32 bar. The control houses a Solenoid valve, a Pressure Control Valve, a Flow Adjustment Valve and a Pressure gauge.

Part No.

A70.093772

Grease Filter



Filter

Part No.	Filtering Degree	Thread
07.261.2	150	3/8"
07.261.3	300	3/8"
07.261.4	150	1/2"
07.261.5	300	1/2"

Spare cartridge

Part No.	Filtering Degree
07.262.4	150
07.262.5	300

Safety Module



The release module is necessary in systems equipped with progressive metering devices or in double-line systems.

Part No.

A70.093820

Tank and Cover



Cover

Part No.	Kg
A72.079514	27
A72.079514	41
A72.079516	180

Complete Tank

Part No.	Kg
A72.079506	27
A72.079507	41

The cover is supplied complete with screws, vent plug, gasket and lifting eyebolts. The tank order code also includes the complete cover.

Level Sensors and Presser Disc must be ordered separately.

Overload Prevention System

The Overload prevention system is designed to improve the safety of workers. It helps prevent leaks that can cause slips and falls and reduce fire hazards. Compatible with any HYDRA grease tank, this product is easy to install, simple to use and reduces the labour work required to fill the tank, freeing personnel for other tasks.

It is made entirely of steel with anti-corrosion plating to withstand harsh environments, and is mechanically operated (does not require electricity).

The system's high-pressure mechanical shut-off valves are available in ½ inch NPT. The system can be operated with or without our grease **Laser Level Sensor**, which can be connected to an indicator at the filling station or in the cabin.

The mechanical grease overflow prevention system is suitable for mining, aggregate and industrial applications, as well as for use on off-road construction machines. Optional components are available for customised installations.

ADVANTAGES

- Improves workers' safety
- Helps avoid cleaning and potential fines
- Easy to install; simple to use
- Mechanical: does not require electricity to work
- Operating pressures of up to 400 bar
- Operating temperature range from -40 to +70°C
- Excess grease goes back to the external tank

Order Codes

Part No.	Description	Fig.
A70.093821	Overload Prevention Kit	1
14.691.0	Release Block	2

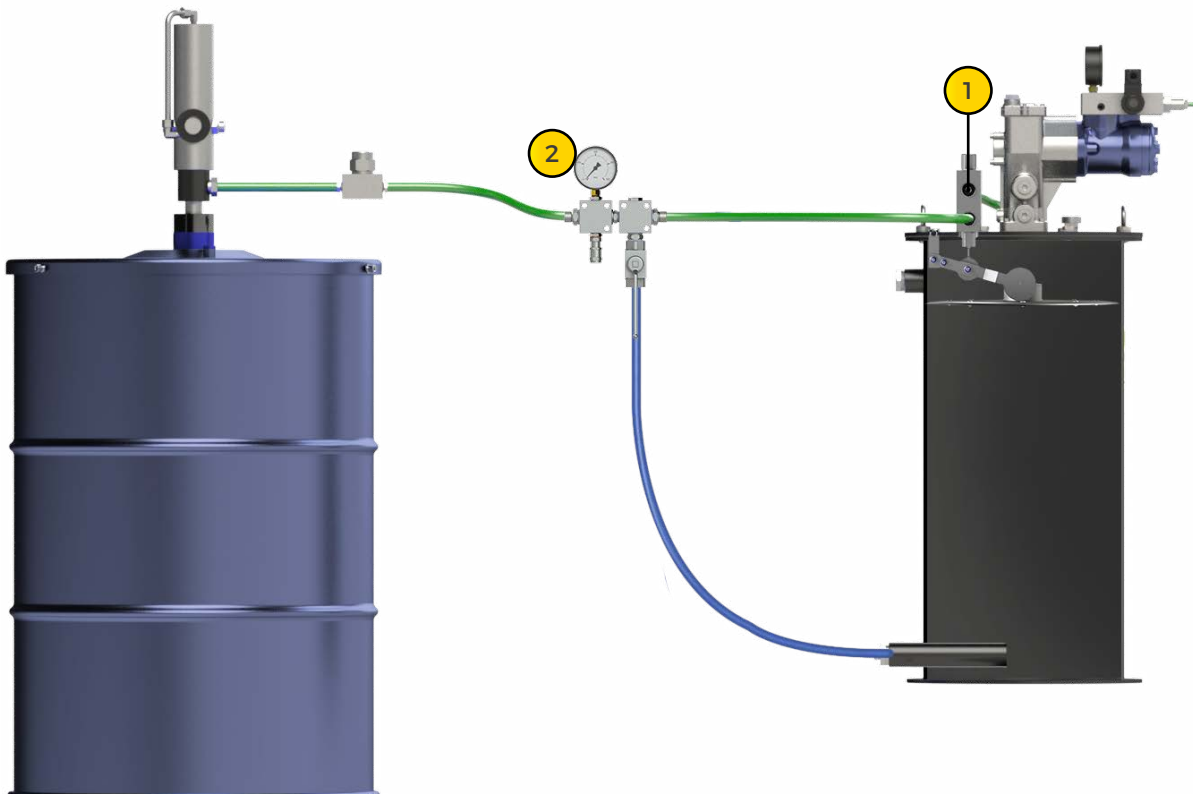

Laser Sensor (minimum and maximum level)



The laser level switch (Class 1) works together with the presser disc and provides a low and high lubricant level signal to the Controller.

Part No.

A91.111548

Presser Disc



The plate slides through the collar, along the pump rod, to ensure that the maximum amount of lubricant is used before topping up.

Dimensions

Part No.

27 / 41 Kg

A70.093768

180 Kg

31.600.4

Pressure switch



The pressure switch works together with the Controller. It monitors the lubricant pressure and reports to the Controller when the set pressure is reached. An adjustment ring nut allows to adjust the pressure between 40 and 400 bar. The pressure switch can be assembled at the end of the line.

Part No.

49.066.7

Controller



It allows adjusting the pause and work times, control alarms and, together with the pressure switch, ensure that the correct pressure is reached before deactivating the pump.

Part No.

86.BCT.24.DC

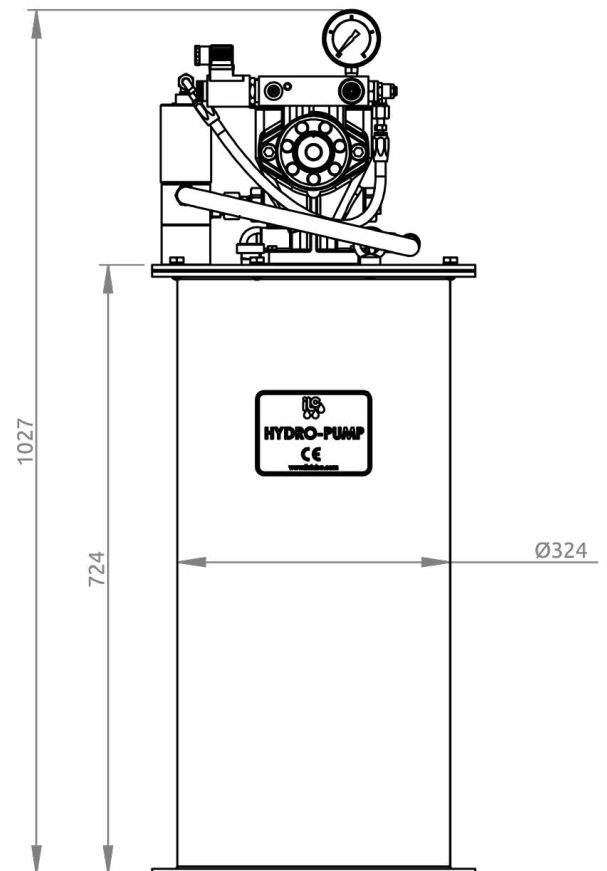
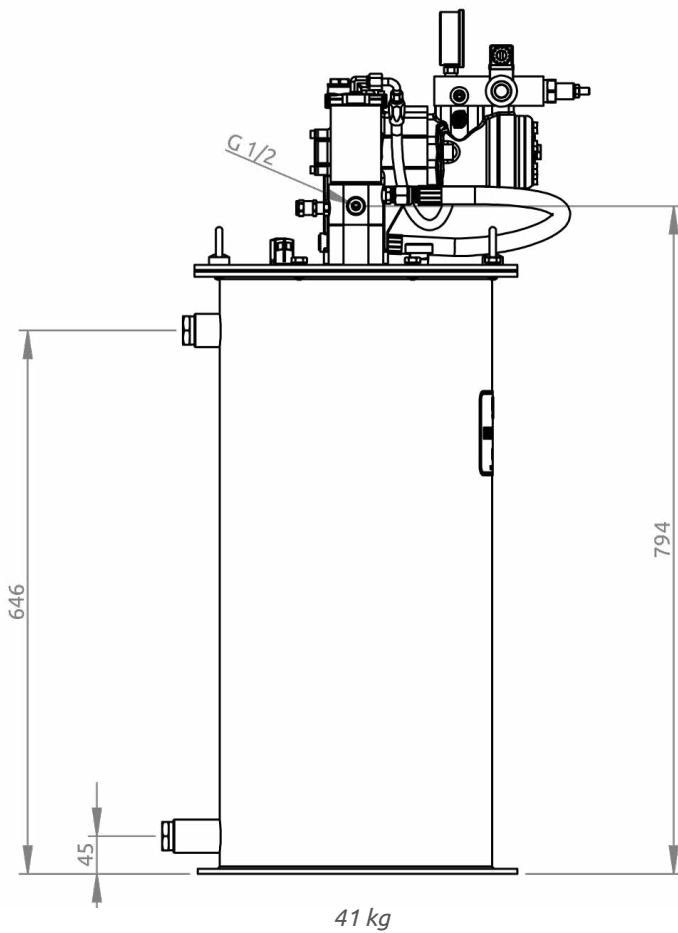
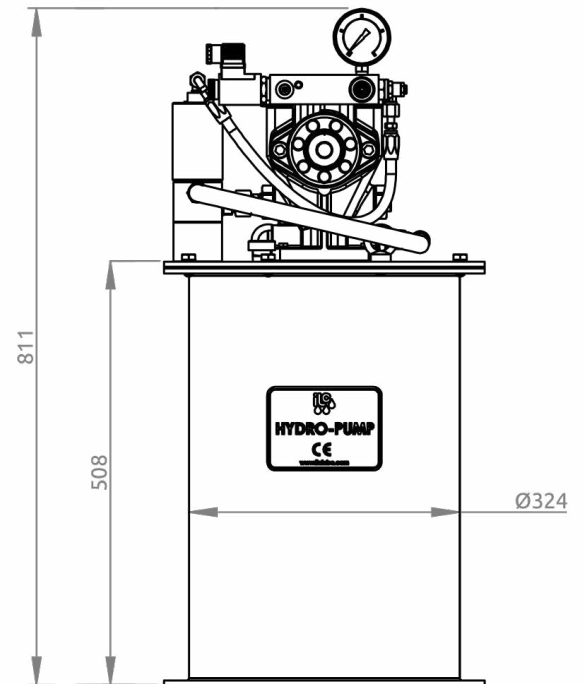
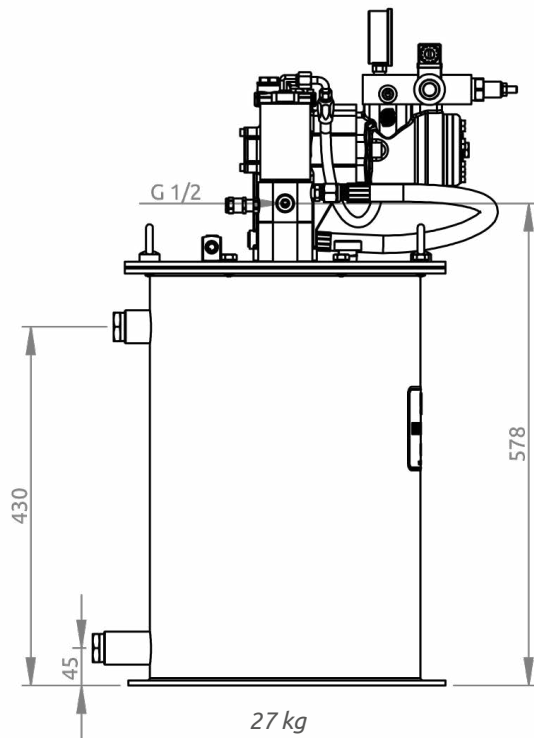

I.L.C. srl - Via Garibaldi, 149 - 20155 Gorla Minore - Italy
Phone +39 0331 601697 - Fax +39 0331 602001 - www.ilclube.com - info@ilclube.it

