

Two-line Lubricant Metering Devices Model VSG-KR / VSL-KR

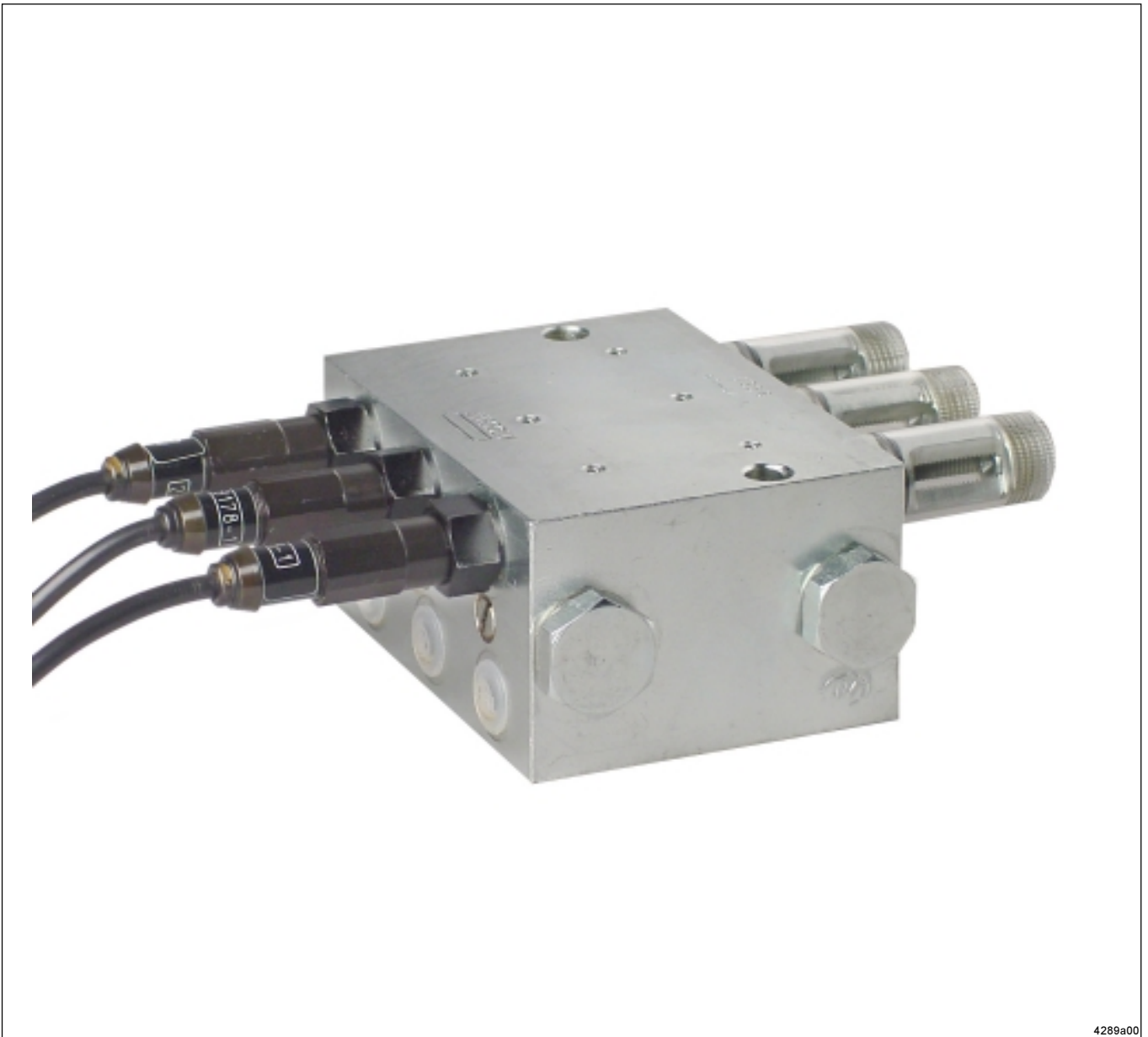

Table of Contents

	Page
General information	2
Technical data	3
Model identification	5
Description of operation	6
Installation	10
Accessories	11
Spare parts	12

Operation, Maintenance and Repair

Repairs should be carried out only by qualified persons who have been charged with the repair work and are familiar with centralized lubrication systems.

Since the pistons in the metering devices are fit with the smallest tolerances, the metering device must be replaced when the pistons are worn.

When synthetic lubricants are used, bear in mind that they must be compatible with the sealing material of the metering devices (polyurethane or Viton).

Use only lubricants which are appropriate for centralized lubrication systems. If in doubt, ask the supplier.

General Information

Appropriate Use

Use the two-line metering devices of the VSG/VSL series only for the supply of lubricant in centralized lubrication systems.

Installation

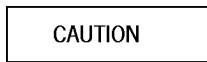

General Safety Instructions



Do not install or remove the metering devices when the system is under pressure or the pump in operation.

- Always protect the centralized lubrication system connected to the pump with a pressure reducing valve.
- Incorrect operation may lead to damage resulting from insufficient or excessive lubrication of bearings or lubrication points.
- Your own alterations or modifications of an installed system should only be carried out if approved with the manufacturer or his appointed dealer.
- Use only original LINCOLN spare parts or parts authorized by LINCOLN

For all work at the metering device, observe extreme cleanliness

- Attach the metering devices to even surfaces without tension.
When base plates are used (see Accessories), first weld the base plates without the metering devices and then attach the metering devices onto them.
- Protect the metering devices from dust and influences of heat (observe the maximum admissible operating temperatures).
- The metering devices must be easily accessible for check and installation work.
- Before connecting the feed lines to the metering devices, fill them with lubricant.
- When connecting the main lines take care to always connect the same line (I or II) to the same metering device inlet.
This makes it easier to check of the metering device because all indicator pins are either in or out after each cycle.

Further Information:

For the VSG-MR version:

Adjusting device with magnetically operated indication of function (1.2A-18002-A96)

For the VSG-KR-NP version:

Data sheet „Piston detector“ (9.3A-20016-A00)

Regulations for Prevention of Accidents

- Adhere to the rules valid in the country where the unit will be in operation.

Subject to modifications

Technical Data VSG-KR

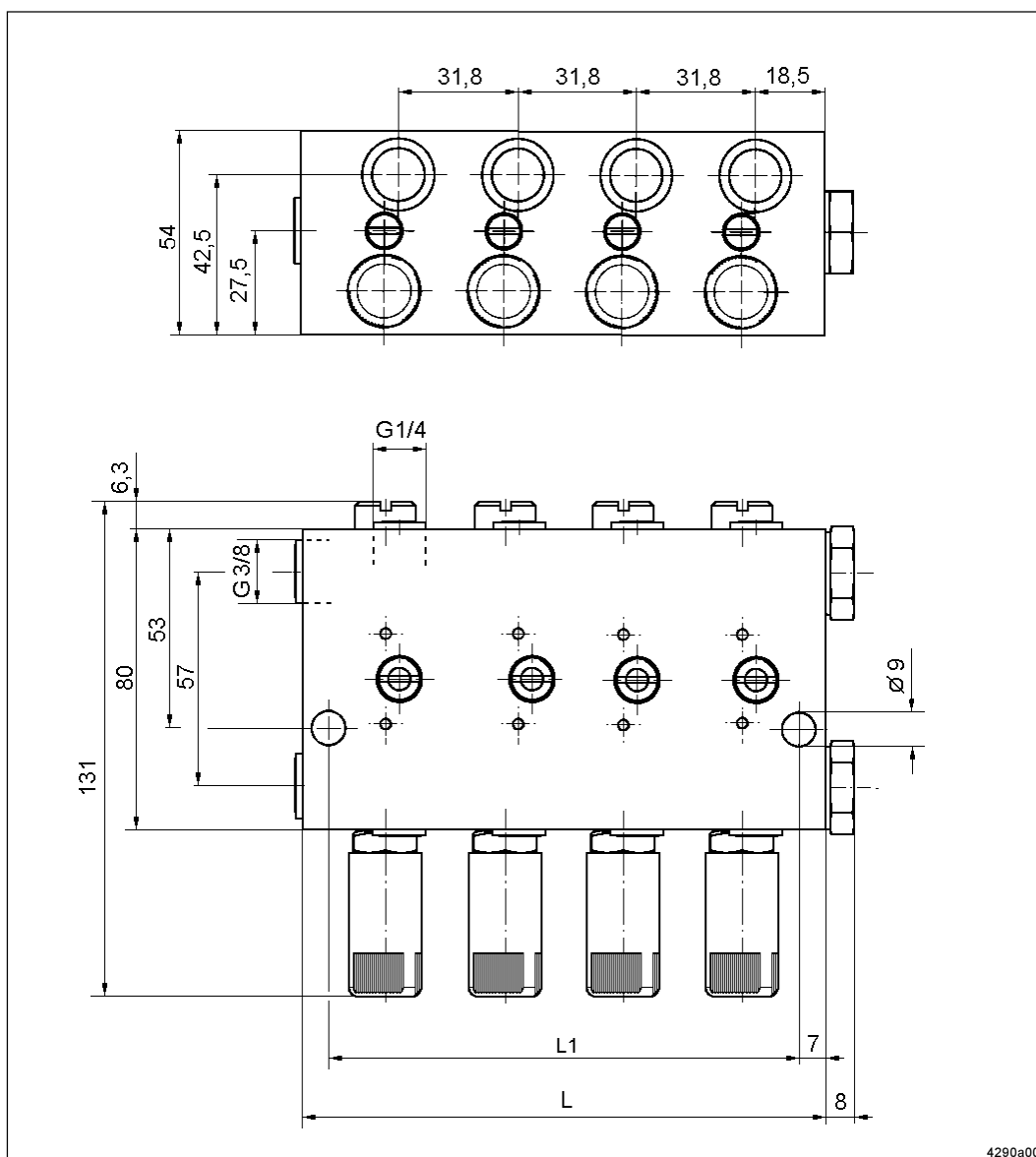

4290a00

TYPE	VSG2-KR	VSG4-KR	VSG6-KR	VSG8-KR
Number of outlets	2	4	6	8
L1 (mm)	30,5	62	94	126
L (mm)	44,5	76	108	140
Part no.	620-40015-1	620-40015-3	620-40015-5	620-40015-7

Technical Data:

Output volume: Q = 0-2,2 cm³/stroke, adjustable
 Operating pressure: p_{max} = 400 bar,
 p_{min} = 35 bar
 Main line connection: G^{3/8}₈
 Feed line connection: G^{1/4}₈

Subject to modifications

Technical Data VSL-KR

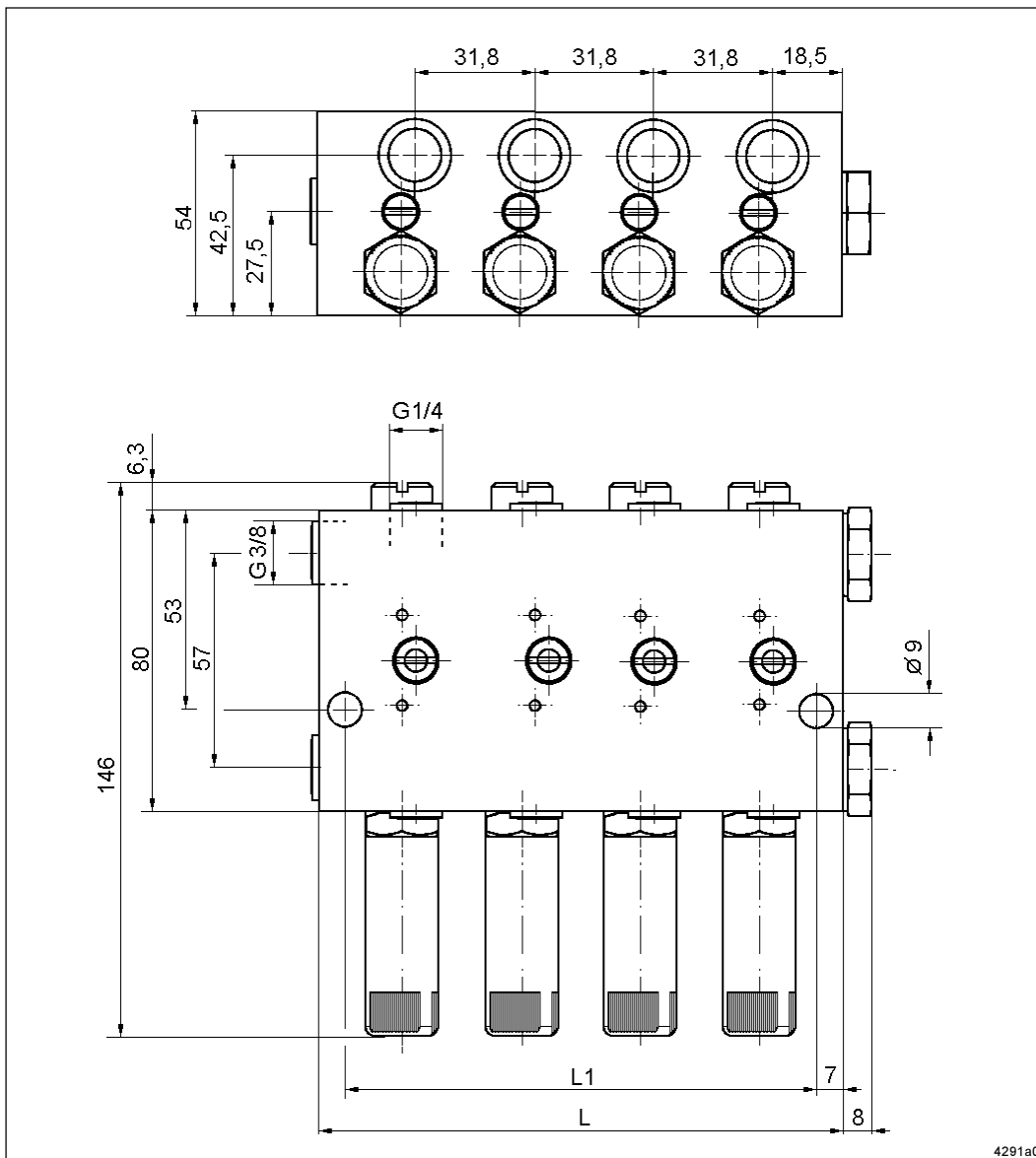

4291a00

TYPE	VSL2-KR	VSL4-KR	VSL6-KR	VSL8-KR
Number of outlets	2	4	6	8
L1 (mm)	30,5	62	94	126
L (mm)	44,5	76	108	140
Part no.	620-40062-3	620-40062-7	620-40064-3	620-40064-7

Technical Data:

Output volume: Q = 0-5 cm³/stroke, adjustable
 Operating pressure: p_{max} = 400 bar, p_{min} = 35 bar
 Main line connection: G³/₈
 Feed line connection: G¹/₄

Subject to modifications

VSG/VSL Identification Chart

Examples of type designations:

VSG	2 - D	1,1		
VSL	8 - KR		FKM	
VSG	6 KR		-	NP
VSG	VA 3 - KR		VA	
VSG	4 - KR		-	KNTU - A
VSG	1 - MR			
VSL	8 - KR		-	KSC

Basic type

- G : Max. output volume 2,2 cm³
- L : Max. output volume 5 cm³

- Standard version
- Steel body, galvanized
- VA : stainless body 1.4305

Number of outlets 1 to 8

Adjusting of output and monitoring

- KR: with indicator pin and progressive adjustment
- KD: with indicator pin and metering screws
- D : with metering screws (output volume in cm³)
- MR: adjustment with magnetically operated indication

Adjusting:

- Standard version: steel, galvanized
- VA : stainless steel 1.4305
- FKM : adjustment with Viton seal (over 80°C)
 (standard: polyurethane)

KN : with indicator pin and progressive adjustment as well as fitted proximity switch per pair of outlets

KA : with indicator pin and adapter (proximity switch to be supplied by customer)

KS : with indicator pin and progressive adjustment as well as fitted limit switch per pair of outlets

NP : with integrated proximity switch (piston detector)

C,TU : internal abbreviations

A : USA-version (NPT thread)

Note: The metering devices model D and KD are supplied with metering screws for maximum output (2.2 or 5 cm³) when no other specification is indicated.

Subject to modifications

Description of Operation

Model VSG, VSL Metering Devices

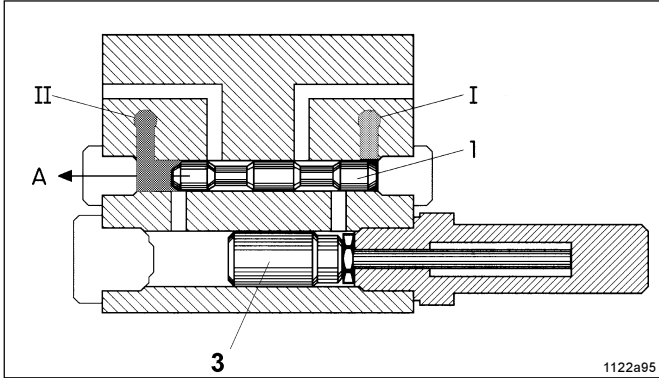

Fig. 1

Stage 1

Pressurised lubricant is supplied to the metering device via main line I. The control piston (1) starts moving in the direction of arrow A, displacing the lubricant in front of the control piston into the relieved main line II.

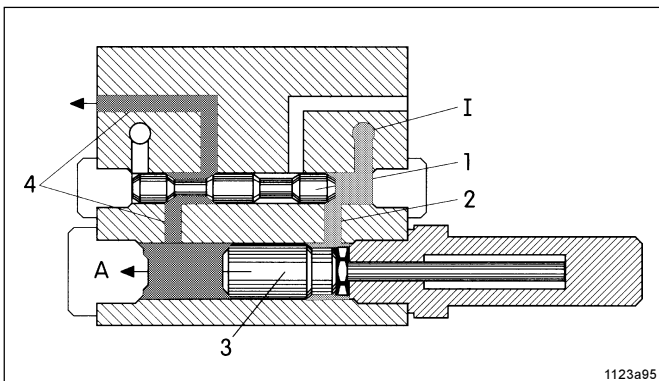

Fig. 2

Stage 2

When the control piston (1) uncovers the connecting passage (2) lubricant is transferred to the right end of the dispensing piston (3), thereby displacing it to the left in the direction of arrow A.

The lubricant volume ahead of the dispensing piston is transferred via the connection passage (4) to the lubrication point. With the dispensing piston in its terminal position, the pressure in main line I will continue to rise to reach the preset change-over pressure of the two-line system. At this stage, the change-over valve of the system operates to connect main line I which has so far been under pressure to the lubricant reservoir of the lubrication pump and the lubricant in main line I is depressurized.

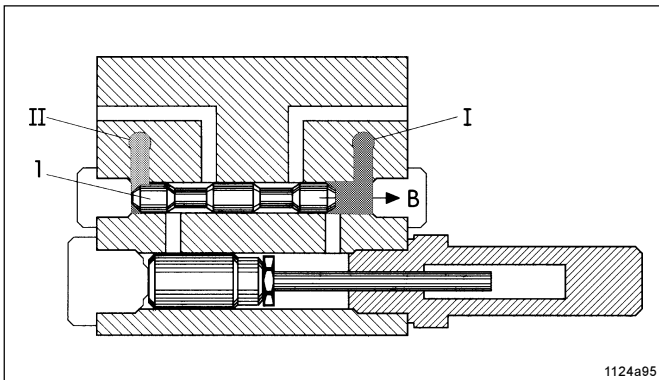

Fig. 3

Stage 3

At the same time the change-over valve connects main line II to the lubrication pump, thus pressurizing the lubricant in this main line. The control piston (1) moves in the direction of arrow B, displacing the lubricant ahead of the control piston into the relieved main line I.

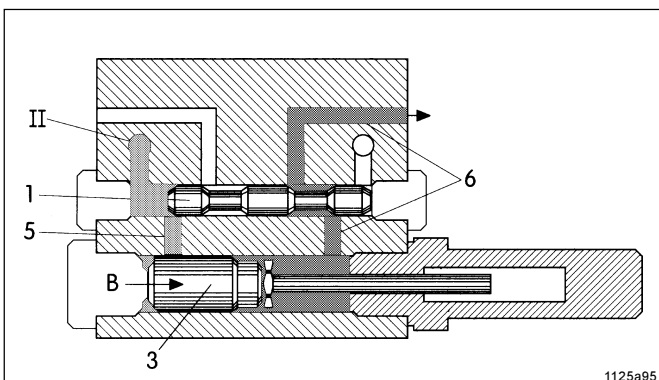

Fig. 4

Stage 4

When the control piston (1) uncovers the connecting passage (5) lubricant is transferred to the left end of the dispensing piston (3) and displaces it to the right in the direction of arrow B. The lubricant ahead of the dispensing piston (3) is transferred via the connecting passage (6) to the lubrication point. With the dispensing piston (3) in its terminal position, the pressure in main line II will continue to rise to reach the preset change-over pressure of the two-line system. At this stage, the change-over valve will once again cause a pressure changing-over in main lines I and II and the cycle will be repeated as described in stage 1.

Model VSG, VSL Metering Devices

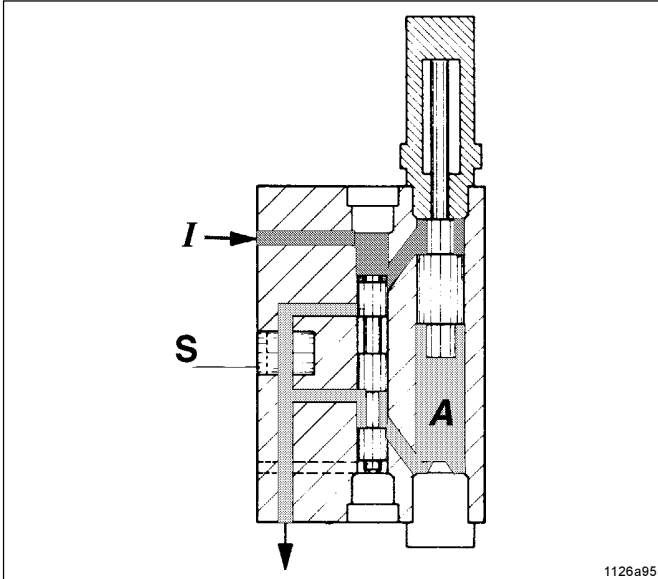

Fig. 5

1126a95

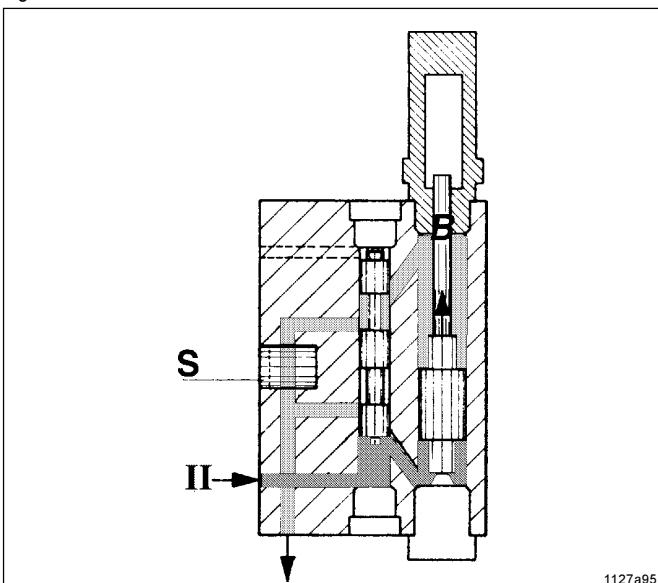

Fig. 6

1127a95

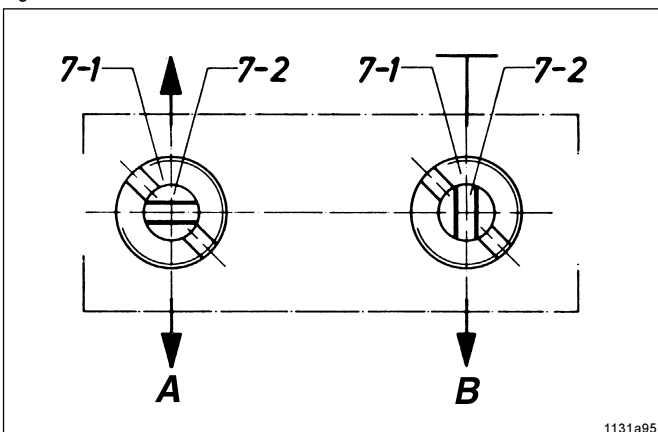

Fig. 7

1131a95

Cross-porting of outlets

This feature enables one outlet only of a pair of outlets to be used, and provides double the lubricant volume output per lubrication cycle.

Figure 5 shows stage 2 and figure 6 shows stage 4 of the operation cycle with this feature operative. All models of the series VSG and VSL are equipped with a lockable rotary slide for each pair of outlets.

Position of cross-porting rotary slide

- 7-1 lock screw
- 7-2 rotary slide horizontal: 2 outlets
- rotary slide vertical: 1 outlet

With the two main lines being relieved (i.e. when the pump is switched off) the lock screw 7-1 can be loosened and the rotary slide 7-2 can be turned through 90°. If the rotary slide is put into position A the connecting passage between the two outlets is closed, and the lubricant is discharged by the two outlets. If the rotary slide is in position B, the connecting passage is open. In this case one of the two outlets has to be closed by means of a closure plug, and then the double lubricant volume is discharged by the other outlet (Table 1).

Subject to modifications

Adjustment of the Output Volume

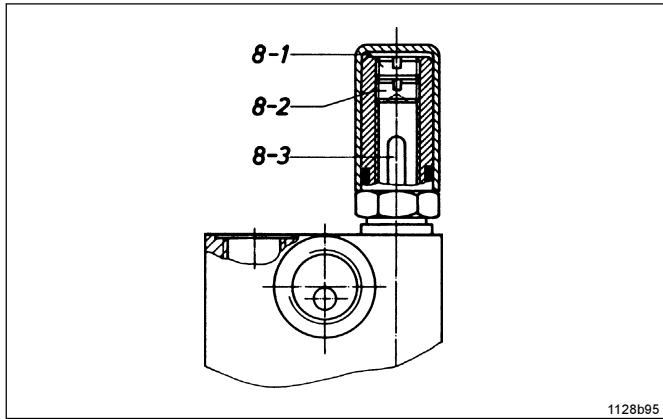

Fig. 8

Variation KR for infinitely variable adjustment and visual indication

Infinitely variable adjustment of lubricant output is achieved by turning the adjustment screw 8-2. Maximum output is available if the lock screw 8-1 and the adjustment screw 8-2 are in their uppermost position. By turning the screw downward the output can be continuously reduced. With the two screws in their fully closed position, the indicator pin 8-3 is completely restrained and, because the pin is attached directly to the dispensing piston, the lubricant output will be nearly zero.

The indicator pin shows the correct functioning of a pair of outlets. After setting the lubricant output, the adjustment screw 8-2 will be locked in position by means of screw 8-1.

CAUTION

To secure the setting, lock the adjusting screw only when the indicator pin is retracted.

Adjustment of the output volume: VSG-KR

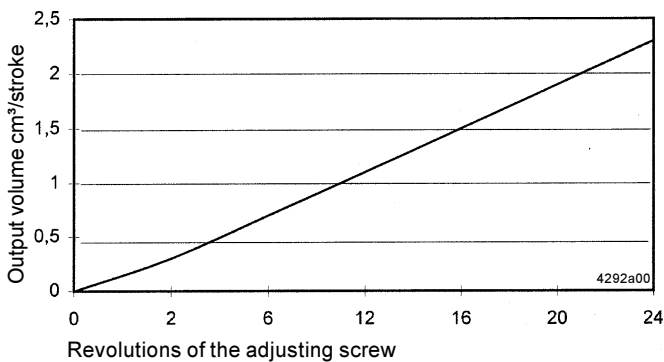

Adjustment of the output volume: VSL-KR

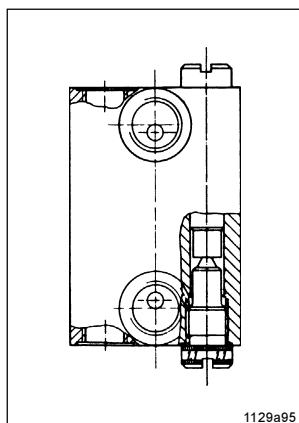
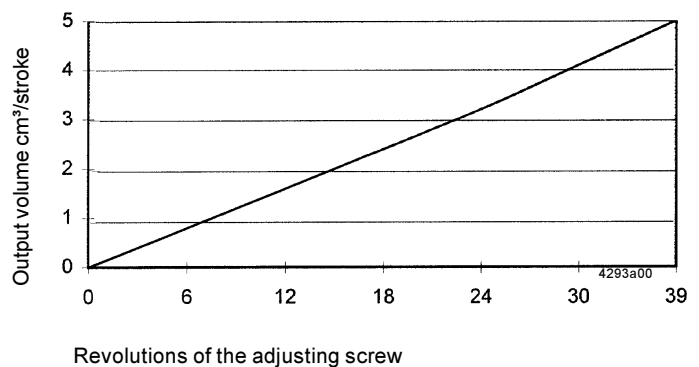

Fig. 9

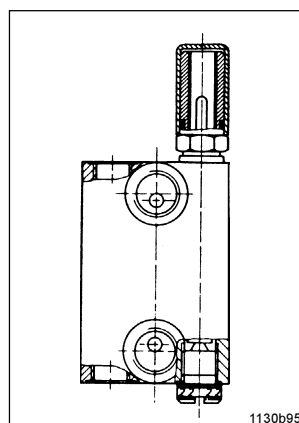

Fig. 10

D and KD variants for graded adjustment of the output volume

All metering devices of the VS series can also be supplied with metering screws as version D (fig. 9) or with metering screws and indicator pin for visual indication as version KD (fig. 10). The interchangeable metering screws limit the stroke of the delivery piston. The longer the metering screw is, the smaller the output volume will be.

For each series there are four metering screws (table 2) which must be ordered separately. The metering devices are supplied with metering screws for the maximum output delivery if no other specification is mentioned on ordering. The D variant is recommended for extreme conditions of operation: high temperatures or aggressive media.

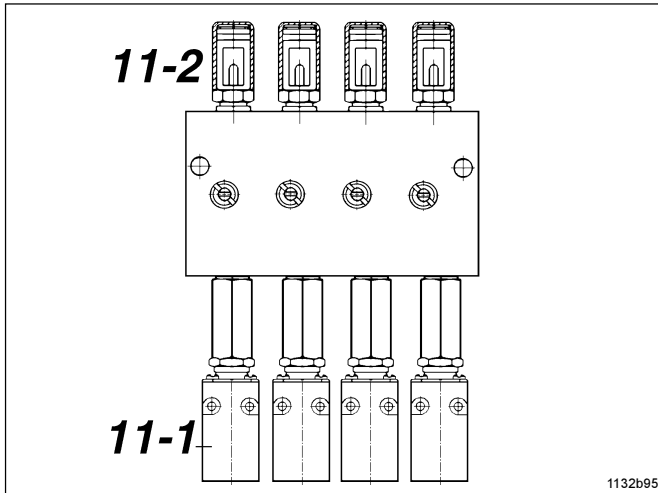

Fig. 11

KS variant

Visual indication and electric signal.

The metering devices of the VSG and VSL series can be equipped with limit switches 11-1 for the remote monitoring of operation of two outlets each. The stroke movement of the delivery piston is transmitted to the limit switch.

Since these metering devices with fitted limit switch are also equipped with the visual indication 11-2 shown in fig. 8, it is easy to find out the malfunctioning pair of outlets in case of a defect.

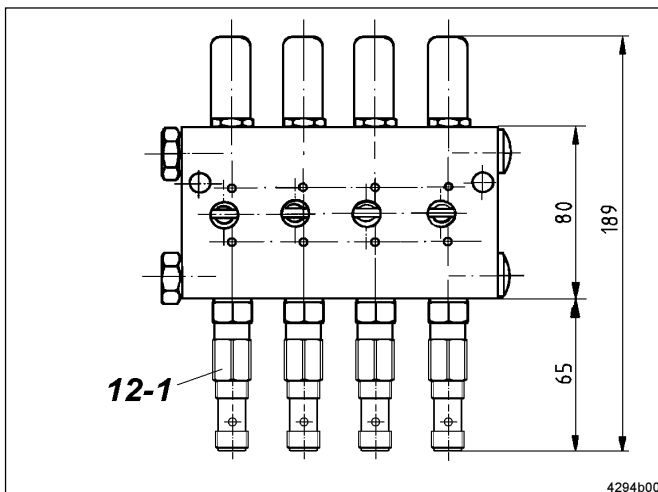

Fig. 12

KR-NP variant

The VSG metering devices can be supplied with a piston detector (item 12-1) for electronic monitoring.

The proximity switch is activated directly via the respective delivery piston, without contact and wear.

The minimum output volume is 0.4 cm³ for this version.

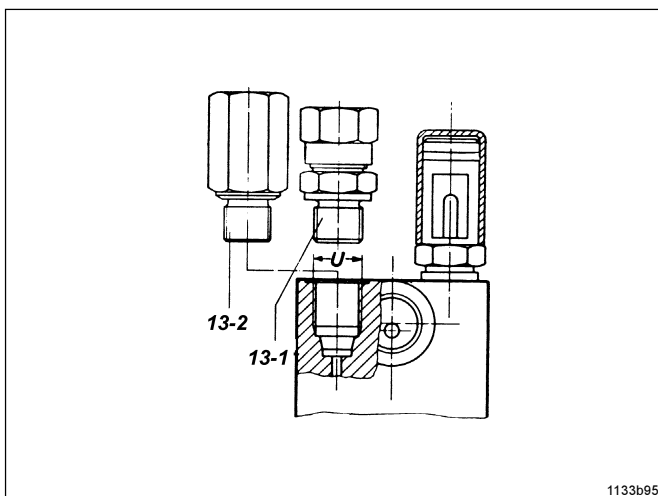

Fig. 13

For feed lines in every length, use the screw-type couplings with cutting ring 13-1 which can be completed with the adapter 13-2 in case of difficult conditions of assembly (table 3). These couplings make it possible to connect the feed lines and the branch lines from both main lines to the VSG and VSL metering devices.

Check valves for VS metering devices

In case of high counter-pressures it is recommended to install check valves in the metering device outlets (table 5).

These are found for example in download progressive metering devices.

Subject to modifications

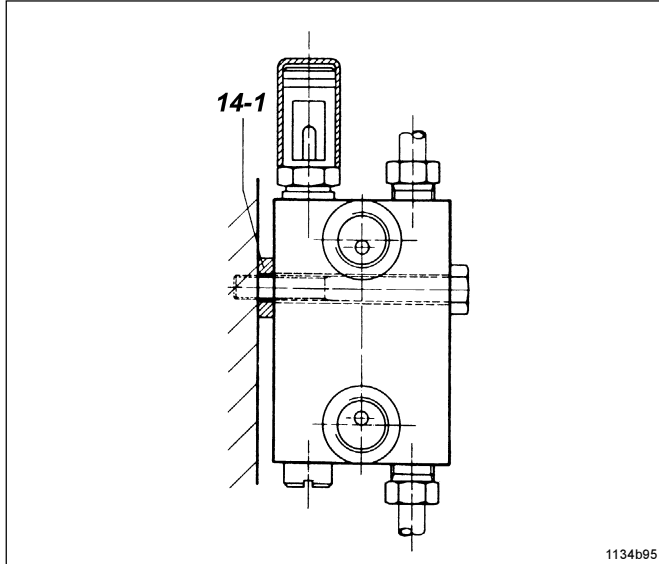

Fig. 14

Installation of VS metering devices

All metering devices may be mounted in any position, so that the indicator pins may point upward, downward, to the right or to the left. To simplify the illustration, fig. 14 and 15 only show the indicator pin pointing upward.

The metering devices can further be installed in such a way that the outlets are in front of the indicator pin (fig. 14) or behind it (fig. 15). The installation shown on fig. 15 has the advantage that the indicator pins cannot be partially covered by the feed lines.

The difficulty of connecting the tube lines with this arrangement can be avoided by using the adapters 13-2 (table 3).

Possible distortions of the metering devices can be avoided by using flexible spacers (14-1 and 15-1). These spacers ensure trouble-free operation of the metering devices even when they are installed on uneven surfaces (table 4).

The VS metering devices with fitted limit switch must in addition be installed with spacers.

Moreover, it is recommended to install them with the feed lines ahead of the limit switches and thus ahead of the indicator pins.

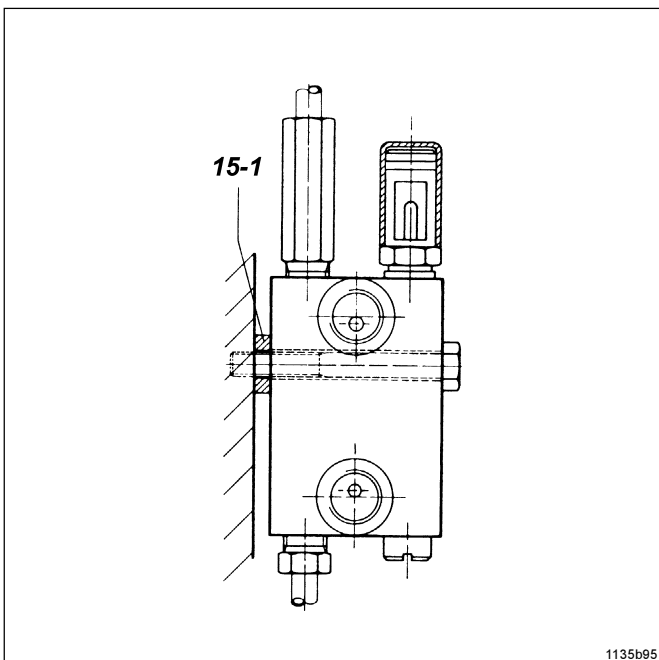

Fig. 15

Accessories

Table 1:
Closure plugs for metering devices with 1 outlet per adjustment

Series	Thread	Part number
VSG/VSL	R1/4"	303-17526-2

Table 3:
Adapter for male connectors acc. to fig 12 (12 - 2)

Metering device	Part number
VSG	Adapter R 1/4"m. x R 1/4"f. Z 420-22139-1
VSL	Adapter R 1/4"m. x R 1/4"f. Z 420-22140-1

Table 2:
Metering screws for KD and D variants acc. to fig. 9 and 10

Series	Marked volumes cm ³ /stroke	Part number
VSG	0.55	303-17505-1
	1.10	303-17506-1
	1.65	303-17507-1
	2.2	303-17508-1
VSL	1.25	303-17509-1
	2.50	303-17510-1
	3.75	303-17511-1
	5.00	303-17512-1

Table 4:
Flexible spacers acc. to fig. 13 and 14

Metering device	Attaching borehole	Spacer	Part number
VSG/VSL	DIA 9	8.5 x 18 x 5	421-21288-1

Table 5:
Check valves for outlets

Tube DIA	Designation	Part number
6 mm	GERV 6 - S G 1/4A VC	223-13052-1
8 mm	GERV 8 - L G 1/4A VC	223-13052-2
10 mm	GERV 10-L G 1/4A VC	223-13052-3

VSG-KR Spare Parts List

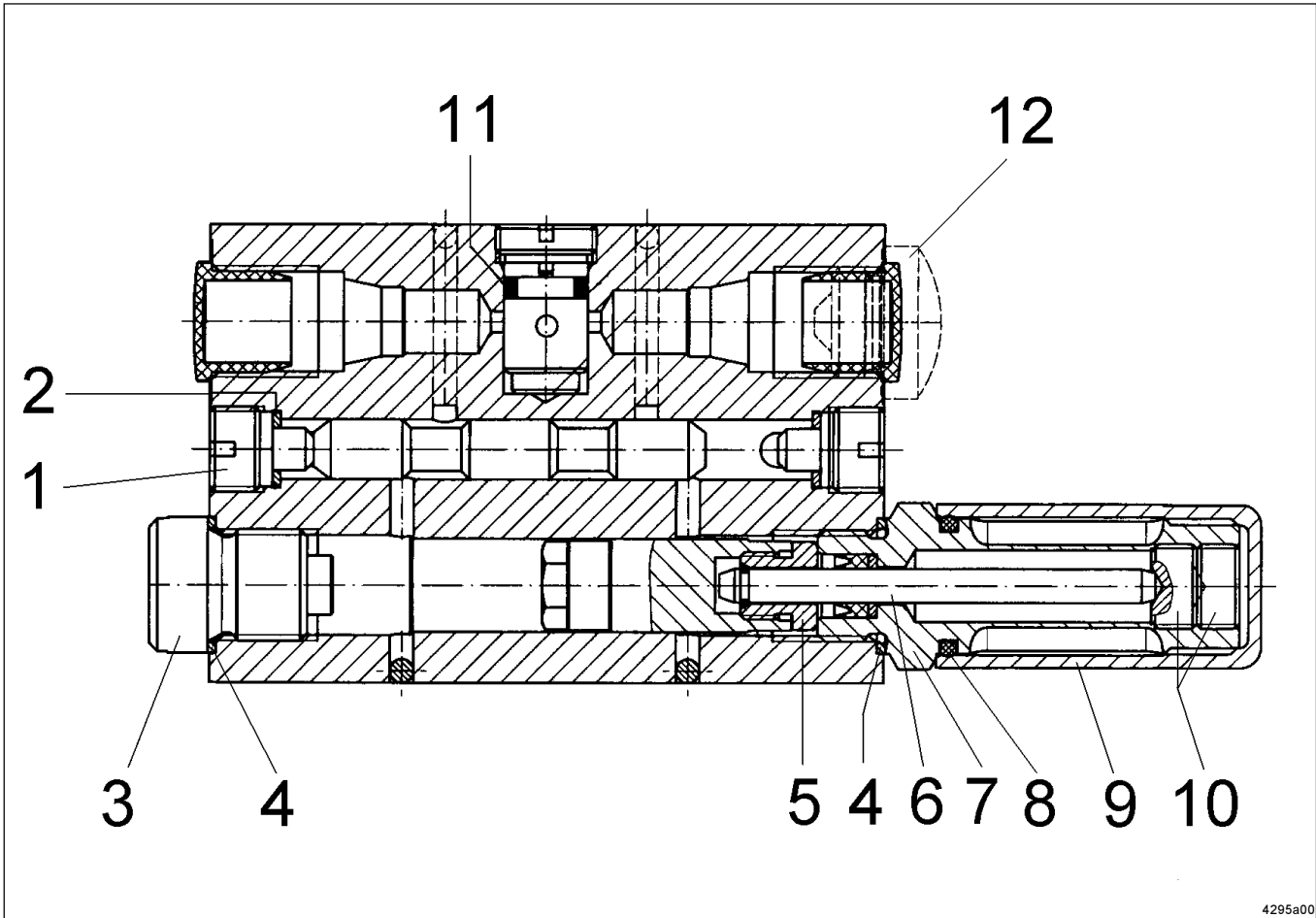

4295a00

Fig. 16

Item	Description	Part no.
1	Closure plug M10 x 1	303-17404-1
2	Copper washer 5 x 9 x 1	209-12158-8
3	Closure plug R1/4"	303-17515-1
4	Copper washer 13.5 x 16 x 1	306-17827-1
5	Holding screw M8 x 1	420-22350-1
6	Indicator pin assy.	520-32066-1
7*	Adjusting sleeve with U-cup sealing ring AU (standard)	520-31488-2
	Adjusting sleeve with U-cup sealing ring FKM (Viton)	520-31899-2
8	O-ring 12 x 2	219-12223-5
9	Protection cap	420-24818-1
	Adjusting device assy. AU (items 7 + 9)	520-34011-1
	Adjusting device assy. FKM (items 7 + 9)	520-34011-2
10	Screw ring M 10 x 1	303-17552-2
11	O-ring 6 x 2	219-12451-5
12	Closure plug	303-17526-2

*includ. item. 8 (O-ring 12 x 2)

Subject to modifications

Ersatzteilliste VSL-KR

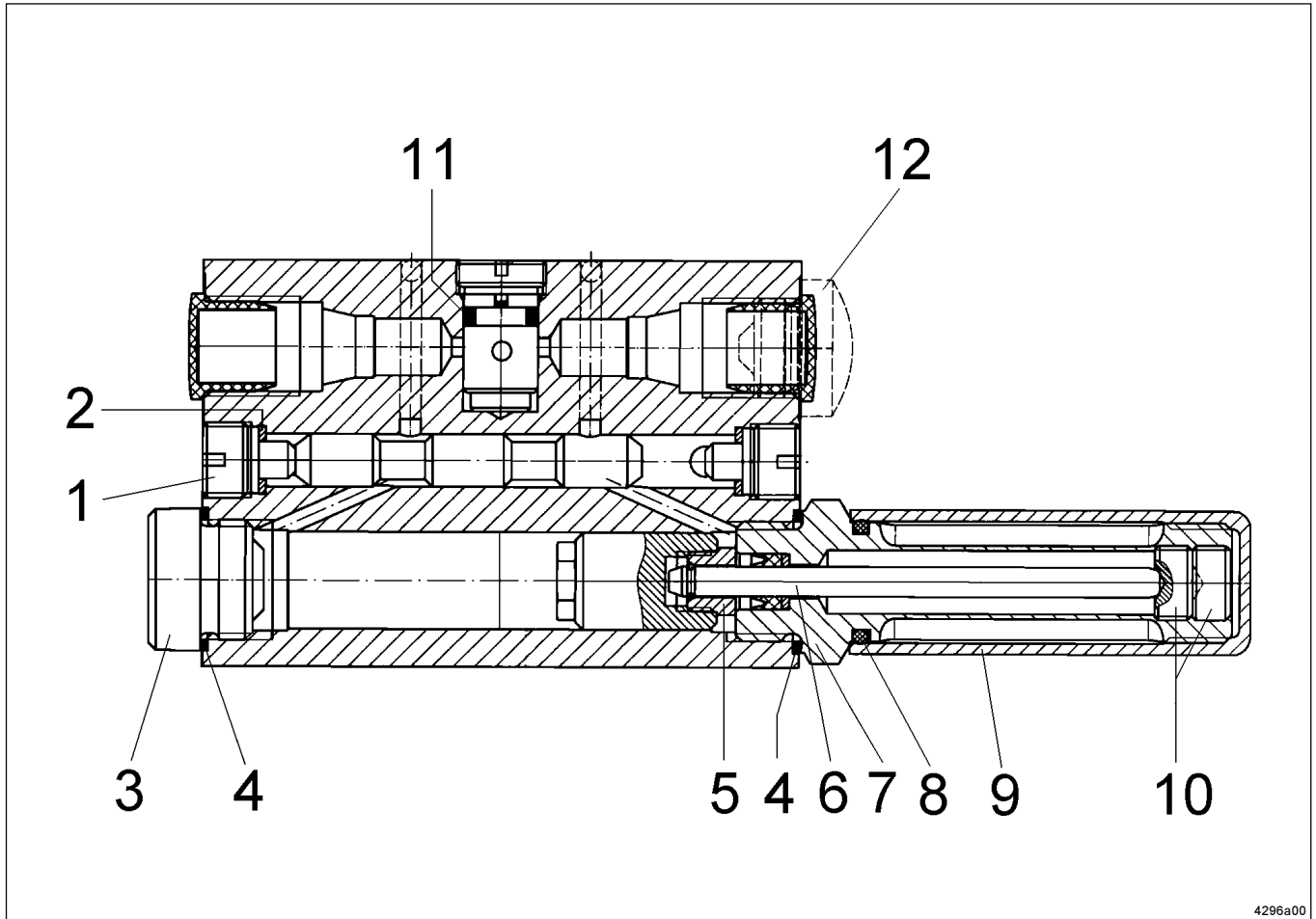

Fig. 17

4296a00

Item	Description	Part no.
1	Closure plug M 10 x 1	303-17404-1
2	Copper washer 5 x 9 x 1	209-12158-8
3	Closure plug M 16 x 1.5	303-17514-1
4	Copper washer 16 x 19 x 1	306-18754-1
5	Holding screw M 8 x 1	420-22350-1
6	Indicator pin assy.	520-32065-1
7*	Adjusting sleeve with U-cup sealing ring AU (standard)	520-31487-2
	Adjusting sleeve with U-cup sealing ring FKM (Viton)	520-31898-2
8	O-ring 12 x 2	219-12223-5
9	Protection cap	420-22136-2
	Adjusting device assy. AU (items 7 + 9)	520-34011-4
	Adjusting device assy. FKM (items 7 + 9)	520-34011-5
10	Screw ring M 10 x 1	303-17552-2
11	O-ring 6 x 2	219-12451-5
12	Closure plug	303-17526-2

*includ. item. 8 (O-ring 12 x 2)

Subject to modifications

**Declaration by the
manufacturer as defined by machinery
directive 89/392/EEC Annex II B**

Herewith we declare that the supplied model of

Metering Device Typ VS...

is intended to be incorporated into machinery covered by this directive and must not be put into service until the machinery into which it is to be incorporated has been declared in conformity with the provisions of the directive.

Applied harmonized standards in particular

EN 292 T1/T2
prEN 809



Walldorf, December 1994, ppa. Z. Paluncic