

Quicklub Oil Pump Model PPGO

Table of contents

Contents	Page
Quicklub oil pump model PPGO	2
Technical Data	2
Commissioning of the system	3
Pump and main lines	3
Outlet combination	3
PPGO with 1,8-litre reservoir (Side view)	4
PPGO with 1,8-litre reservoir(Front view)	5
Spare parts list	6
Troubleshooting	7

Quicklub Oil pump Model PPGO

Technical Data

Pump pressure ratio	40:1
Air pressure	min. 4 bar
.....	max.10 bar
Max. operating pressure	250 bar
Air inlet	1/8"BSP
Lube outlet	see outlet fittings
Reservoir capacities PPGO 18	1.8 litre
Lubricant output per pump stroke	2,6 cm ³
Lubricant output per outlet	0,2 cm ³

Filling of reservoir

The reservoir is filled through the filler cap at the top of the reservoir. The strainer **must** be in place when filling the reservoir. Strainer should be removed and cleaned periodically.

Important: Since one pump stroke corresponds to approximately 1.6 cycles of the eight outlet progressive metering device, the average lubricant output is **0.3 cm³ per outlet and pump stroke**.

Description

The QUICKLUB pump model PPGO is used in a progressive type centralized lubrication system. It is an air operated, single-stroke pump that requires the use of a 3/2-way air valve for the activating of the pneumatic cylinder. It has a clear reservoir for visual inspection of oil level.

Important: Never use solvents for cleaning the clear reservoir.

Operation

When the solenoid is energized, compressed air enters the bottom of the air cylinder and moves the piston upward. As the piston moves upward, the ball seat of the suction valve prevents the lubricant from returning to the lubricant reservoir. Lubricant is therefore distributed to the eight outlets by the integrated progressive metering device. When the solenoid is de-energized, the compressed air escapes from the air cylinder. The piston spring moves the piston downward. The suction valve unseats allowing lubricant from reservoir to refill the discharge cavity in the pump body for the next lubrication cycle.

Important: Pump must be installed in vertical position.

Commissioning of the system

Pump and main lines

After the reservoir has been filled with recommended lubricant, loosen vent screw counter nut and open vent screw approximately one turn (DO NOT REMOVE).

Also, loosen main line fittings. Operate pump until lubricant flows from vent screw, then tighten vent screw and counter nut. Continue to operate pump until lubricant flows loosened main lines. Then tighten metering device inlet fitting. Repeat procedure until all main lines are filled.

Outlet combination

The lubricant output of one outlet is 0.2 cm³. When an outlet is closed using a closure plug, the lubricant output is automatically redirected internally and combined to the output of the next adjacent outlet in ascending numerical order (see example 1: outlet 2 and 4 to outlet 6, and outlet 1 to outlet 3); expect when either outlet 7 and /or 8 is closed.

Examples:

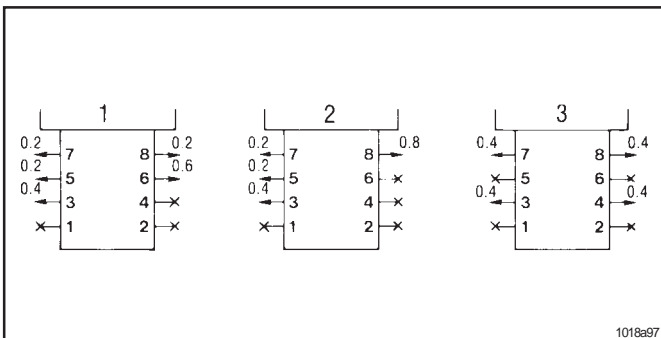

Examples:

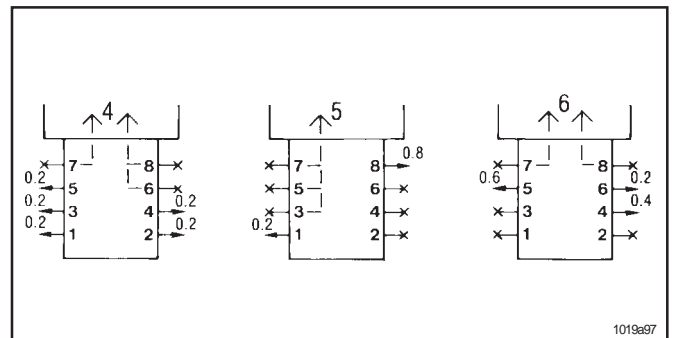

When outlet 7 and /or 8 is closed, the output from either or both of these outlets plus that of any immediately adjacent closed outlet (outlet 6) as shown in example 4, is automatically redirected internally to the pump reservoir.

- ← Delivering outlet (lubricant output in cm³ per piston stroke)
- ⊗ Closed outlet

Note: The outlet combinations procedure for the **Quicklub** pump is different from that for the **Quicklub** metering device. See „Technical Description“ for progressive metering devices, page 6.

PPGO with 1,8-litre reservoir (Side view)

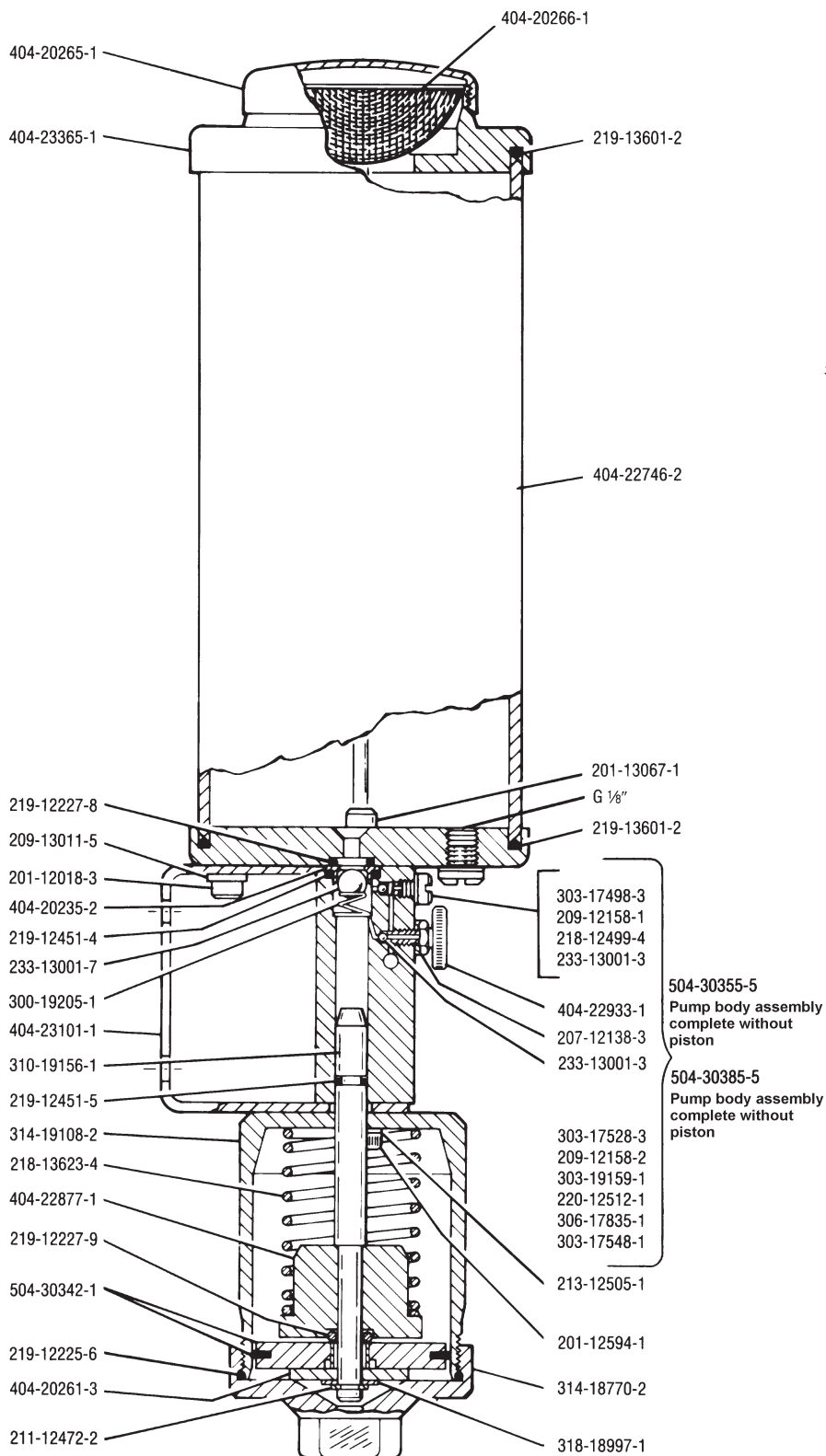

Subject to modifications

1024b97a

PPGO with 1,8l-itre reservoir (Front view)

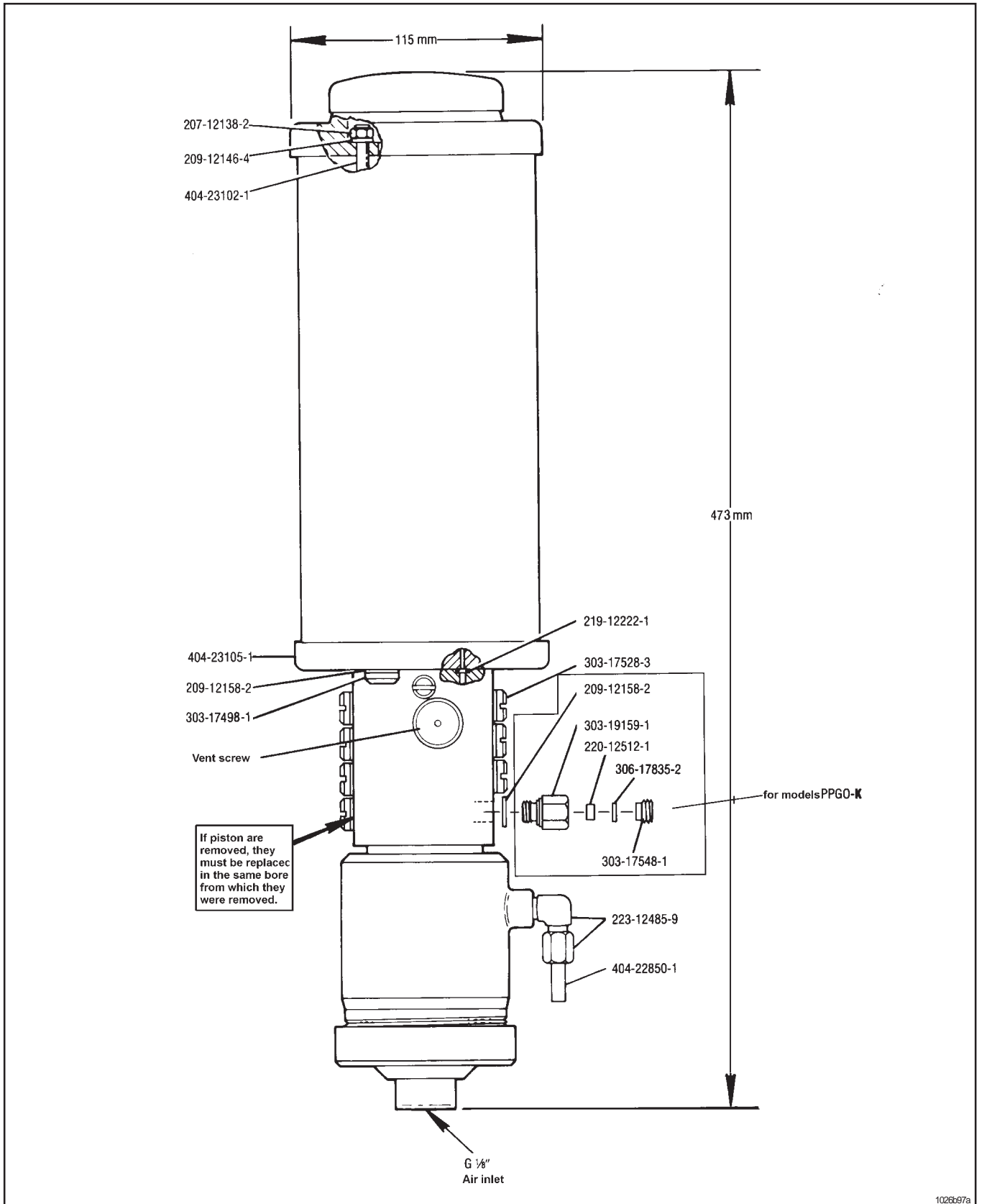

Subject to modifications

1026x97a

Spare parts list

PPGO with 1,8-litre reservoir

Description	Qty.	Part No.
1 Hex. socket head screw	2	201-12018-3
2 Hex. socket head screw	2	201-12594-1
3 IHex. socket head screw	2	201-13067-1
4 Hex. nut	2	207-12138-2
6 Hex. nut	1	207-12138-3
7 Washer	2	209-12146-4
8 Gasket	1	209-12158-1
9 Gasket	9	209-12158-2
10 Washer	2	209-13011-5
11 Retaining ring	1	211-12472-2
12 Spring washer	2	213-12505-1
13 Compression spring	1	218-12499-4
14 Compression spring	1	218-13623-4
15 O-ring	2	219-12222-1
16 O-ring	1	219-12225-6
17 O-ring	1	219-12227-8
18 O-ring	1	219-12227-9
19 O-ring	1	219-12451-4
20 O-ring	1	219-12451-5
21 O-ring	2	219-13601-2
22 U-cup sealing ring	1	220-12512-1
23 WE6-LLR1/8 KC	1	223-12485-9
24 Steel ball	2	233-13001-3
25 Steel ball	1	233-13001-7
26 Compression spring	1	300-17228-1
27 Compression spring	1	300-19205-1
28 Closure plug	1	303-17498-3
29 Closure plug	9	303-17528-3
30 Threaded ring	1	303-17548-1
31 Closure plug	1	303-19159-1
32 Gasket	1	306-17835-2
33 Piston	1	310-19156-1
34 Bottom	1	314-18770-2
35 Cylinder	1	314-19108-2
36 Washer	1	318-18997-1
37 Ball seat	1	404-20235-2
38 Washer	1	404-20261-3
39 Cover	1	404-20265-1
40 Strainer	1	404-20266-1
41 Reservoir tube	1	404-22746-2
42 Vent tube	1	404-22850-1
43 Stop	1	404-22877-1
44 Vent screw	1	404-22933-1
45 Bracket	1	404-23101-1
46 Securing stud	2	404-23102-1
47 Bottom	1	404-23105-1
48 Adapter	1	504-30365-1
49 Pneumatic piston dia. 63	1	504-30342-1
50 Pump body assembly complete without piston	1	504-30355-5
51 Pump body assembly complete without piston	1	504-30385-5

Outlet fittings

for tube O.D. 6 mm

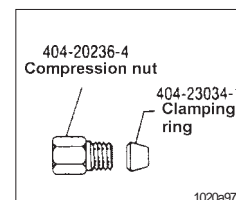

for tube O.D. 6 mm - check valve

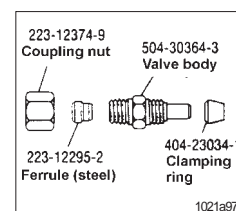

for tube 4 mm - check valve

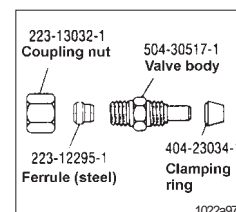

Closure plug

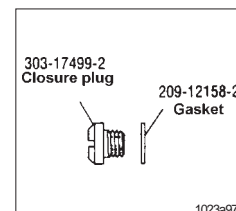

Note:

1. All tube fittings **must** be original QUICKLUB fittings to assure proper operation of pump.
2. All outlets fittings **must** be selected and ordered separately.

Subject to modifications

Troubleshooting

<ul style="list-style-type: none"> • Fault: Pump operates without delivering lubricant 	
<ul style="list-style-type: none"> • Cause 	<ul style="list-style-type: none"> • Remedy
<ul style="list-style-type: none"> • Lubricant reservoir empty. • Vent air from the pump. 	<ul style="list-style-type: none"> • Check lubricant level in reservoir and fill if necessary. • Refer to instruction under „Commissioning of the pump“ .
<ul style="list-style-type: none"> • Fault: No air pressure to air cylinder 	
<ul style="list-style-type: none"> • Cause 	<ul style="list-style-type: none"> • Remedy
<ul style="list-style-type: none"> • 3/2 - way valve defective. 	<ul style="list-style-type: none"> • Check solenoid valve, repair or replace, if necessary.
<ul style="list-style-type: none"> • Fault: Although compressed air is available at air cylinder, piston does not complete its stroke (indicator pin does not move) 	
<ul style="list-style-type: none"> • Cause 	<ul style="list-style-type: none"> • Remedy
<ul style="list-style-type: none"> • Blockage in delivery line. 	<ul style="list-style-type: none"> • With air supplied to pump, loosen fittings on pump body in turn and check for lubricant delivery. Then loosen fittings at metering devices or at lubrication points until lubricant emerges from outlets and pump actuates. This will indicate in which line the blockage has occurred. Clear blockage. Tighten all loose fittings.
<ul style="list-style-type: none"> • Fault: Air escapes from cylinder vent tube with air cylinder operating and piston at top of stroke 	
<ul style="list-style-type: none"> • Cause 	<ul style="list-style-type: none"> • Remedy
<ul style="list-style-type: none"> • O-ring 219-13043-6 or pneumatic piston 504-30342-1 	<ul style="list-style-type: none"> • Disconnect air supply. Unscrew bottom 314-18770-2 from air cylinder. Remove piston and disassemble all parts. Replace O-ring 219-12451-5, O-ring 219-13043-6, pneumatic piston 504-30342-1 with gasket and retaining ring 211-12472-2. Reassemble piston and lubricate lightly with oil. Loosen vent screw counter nut, open vent screw approximately one turn (DO NOT REMOVE) and install piston assembly. Replace O-ring 219-12225-6 and reassembly air cylinder bottom. Reconnect air supply. Operate pump until lubricant flows from ventscrew, then tighten vent screw and counter nut.
<ul style="list-style-type: none"> • Fault: Lubricant discharged from vent tube 	
<ul style="list-style-type: none"> • Cause 	<ul style="list-style-type: none"> • Remedy
<ul style="list-style-type: none"> • O-ring 219-12451-5 worn or damaged. 	<ul style="list-style-type: none"> • Disconnect air supply. Unscrew bottom 314-18770-2. Remove piston and replace O-ring 219-12451-5. <p>Important: Before tightening, center cylinder on bore hole of pump body.</p>

Subject to modifications

<p>Lubricate piston lightly with oil. Loosen vent screw counter nut, open vent screw approximately one turn (DO NOT REMOVE) and install piston. Replace O-ring 219-12225-6 and reassemble bottom to air cylinder. Reconnect air supply. Operate the pump until lubricant flows from vent screw, then tighten vent screw and counter nut.</p>	
<p>• Fault: Oil leaking between reservoir and reservoir base</p>	
<p>• Cause</p>	<p>• Remedy</p>
<p>• O-ring 219-13601-2 ist damaged.</p>	<p>• With reservoir empty, unscrew two nuts 207-12138-2 and remove reservoir. Replace O-ring in reservoir bottom. Reassemble reservoir to base and secure with two nuts.</p>
<p>• Fault: Oil leaking between pump body and reserboir base</p>	
<p>• Cause</p>	<p>• Remedy</p>
<p>• O-ring 219-12451-4, O-ring 219-12227-8 or O-ring 219-12227-8 worn or damaged.</p>	
<p>• Fault: Pump actuates without delivering lubricant</p>	
<p>• Cause</p>	<p>• Remedy</p>
<p>• Ball of check valve 233-13001-7 and ball seat 404-20235-2 dirty, worn or damaged.</p>	<p>• With reservoir empty, unscrew two nuts 207-12138-2 and remove reservoir. Unscrew two hex. socket screws 201-13067-1 and 201-12018-3 and remove reservoir base. Disassembly suction valve and replace O-ring 219-12451-4. Clean and inspect ball of check valve 233-13001-7 and ball seat. 404-20235-2, and replace if necessary. Replace two O-rings 219-12222-1 in pump body and 219-12227-8 in reservoir base and assemble base to pump body with two. hex. socket screws 201-13067-1.</p> <p>Important: Pump body must be flush with reservoir base.</p> <p>Fasten mounting bracket to reservoir base with two hex. socket screws 201-12018-3.</p>