

QUICKLUB

Progressive Metering Devices for Grease and Oil

Model SSV and SSV M

Planning and Layout of Progressive Centralized Lubrication Systems

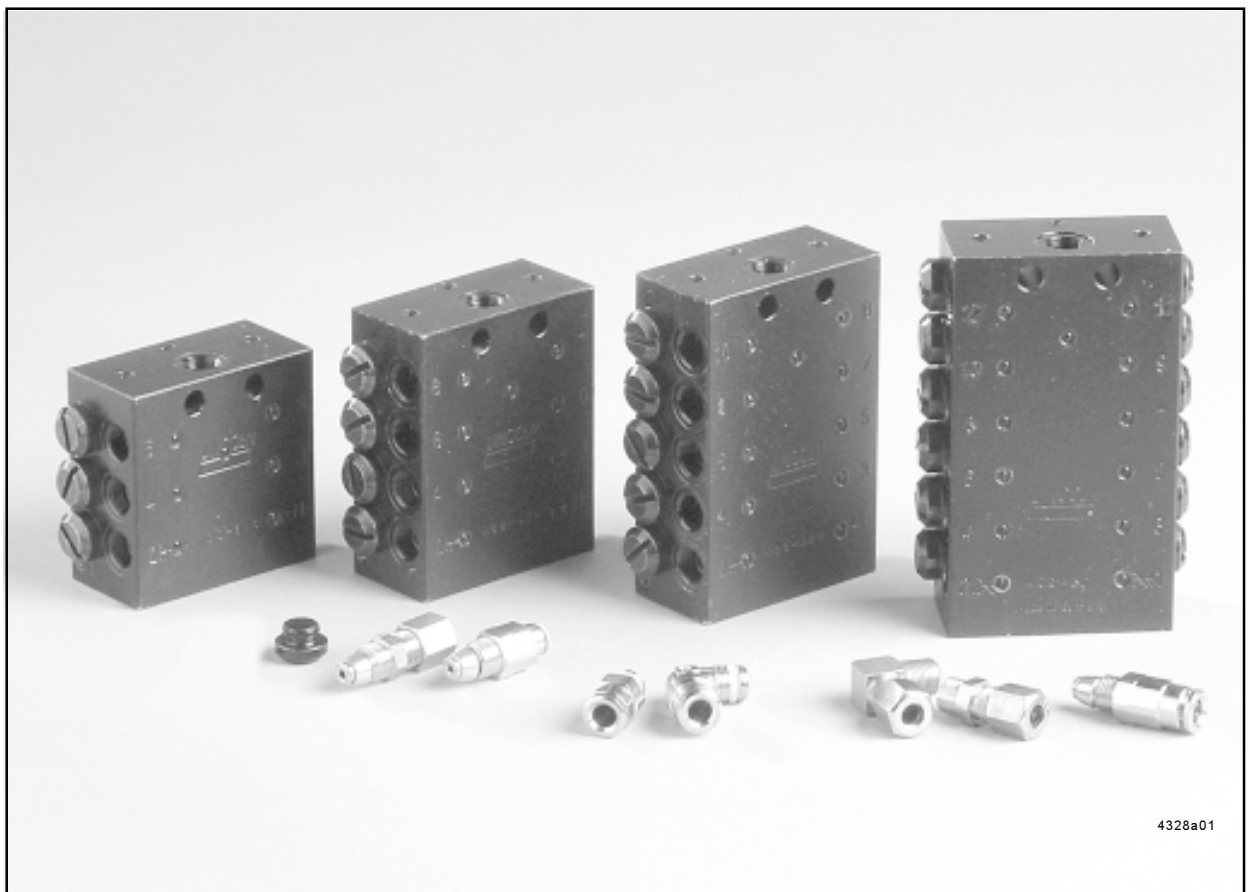

4328a01

Safety Instructions

Appropriate Use

- Use the SSV lubricant metering devices only for dispensing lubricants in centralized lubrication systems.

General Safety Instructions

- The progressive centralized lubrication system connected to the QUICKLUB pump model 203 must always be secured with a safety valve.
- LINCOLN SSV and SSV M lubricant metering devices are state of the art.
- Incorrect use may result in bearing damage caused by poor or over-lubrication.
- Each outlet which will be used must be equipped with a check valve.
- **In the case of the metering devices model SSV 6 - 22** the outlets 1 and/or 2 must never be closed. **In the case of the assembled metering devices model SSV 14 - 22**, the two outlets with the highest numbers must never be closed.
- Unauthorized modifications or changes to an installed system are not admissible. Any modification must be subject to prior consultation with the manufacturer of the lubrication system.
- Use only original LINCOLN spare parts (see Parts Catalog) or the parts approved by LINCOLN.

Regulations for Prevention of Accidents

- Adhere to the regulations for prevention of accidents which are effective in the country where the system is to be used.

Operation, Repair and Maintenance

- Repair should only be performed by:
 - authorized and
 - instructed personnelwho are familiar with the centralized lubrication systems.

Installation

- Install the metering devices at a suitable location in accordance with the lubrication diagram.
- It is recommended that the metering devices be installed in such a way that the outlets are not close to the chassis or the attaching plate. This will facilitate troubleshooting in the case the system is blocked.

- The main metering devices with indicator pin must be installed in such a way that the indicator pin is easily visible.

When the push-in type fittings are used, note the following:

- For the metering **device inlet** use only **push-in type fittings** with **reinforced collar** and sealing ring.
- For the **outlet tube fittings** of the **SSV dividervalue** (M 10x1) depending on the design of the lubricant line, for example
 - high pressure plastic hose (\varnothing 8,6 x 2,3) use valve bodies with reinforced collar only, or,
 - pressure plastic tube (\varnothing 6 x 1,5) use valve bodies with knurled collar only
- For the **outlet fittings** of the **SSV M divider** divider valve (M 8x1) pressure plastic tube (\varnothing 4 x 1) use valve bodies with knurled collar only.

NOTE: In the case of construction machines or agricultural machines use high pressure plastic hoses for the lubricant feed lines. In such cases the outlet fittings of the secondary metering devices and the connection fittings to the lubricant points must have a reinforced collet.

- Use only the main and feed lines specified by LINCOLN and adhere to the specified system pressures.

Table of Contents

	Page		
		Tube fittings, push-in type (main metering device)	10
			Page
Safety instructions	2		
Progressive metering devices			
model SSV and SSV M	4	Tube fittings, push-in type	11
Suitable lubricants	4	(secondary metering device)	11
Progressive metering devices - General	4	Single lubricant output	11
Features of a progressive metering device	4	Double or multiple lubricant output	11
Different features of SSV and SSV M	4	Lubricant metering devices model SSV 14 to SSV 22	12
Applications	5	Tube fittings, push-in type	12
Lubricant distribution within the metering device	6	Metering device	13
Interruption of the lubricant supply	7	Connection of the lubricant feed lines and main line	14
Monitoring of the operation	8	Protective cap for push-in type fittings	14
System-dependent monitoring	8	Pressure plastic tubes and high-pressure	
Visual monitoring	8	plastic hoses	15
Electrical monitoring	8	Troubleshooting	16
Determining the lubricant output by combining outlets	9	Planning and layout	18
Tube fittings, screw-type (main and secondary metering devices)	9	Instructions for QUICKLUB progressive systems	18
		Technical data	25
		Tightening torques	26
		Dimensions	26
		Lubricants	27

Further information can be found in the following manuals:

Technical Description QUICKLUB Pump 203
 Technical Description for "Electronic Control Units" of pump 203 :

- Printed-Circuit Board 236-13891-1 - Model V10 - V13*
- Printed-Circuit Board 236-13857-1 - Model H *
- Printed-Circuit Board 236-13870-1 - Models M 00 - M 15*
- Printed-Circuit Board 236-13870-1 - Models M 16 - M 23*
- Timer 236-13860-1 - Model PSG 02
- Installation Instructions
- Parts Catalog

* The design of the printed circuit board is indicated by the model designation which is part of the pump type identification code mentioned on the pump nameplate. Example: B. : P 203-2XN - 1K6 - 24 - 1A1.10 - **V10**

Subject to modifications

Progressive Metering Devices Model SSV and SSV M

Suitable Lubricants

- The progressive metering devices model SSV can be used for dispensing
- mineral oils of at least 40 mm²/s (cST) or
- greases up to the penetration class NLGI 2

Progressive Plunger Metering Devices - General

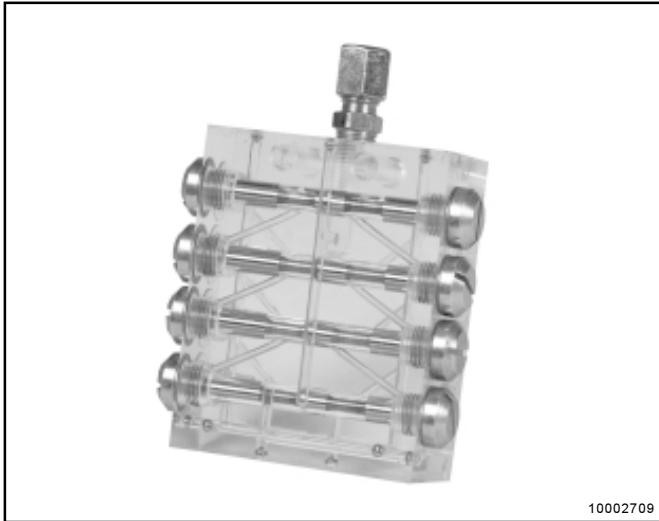

Fig. 2 - Metering device type SSV 8 shown as a demonstration model

Features of a Progressive Metering Device

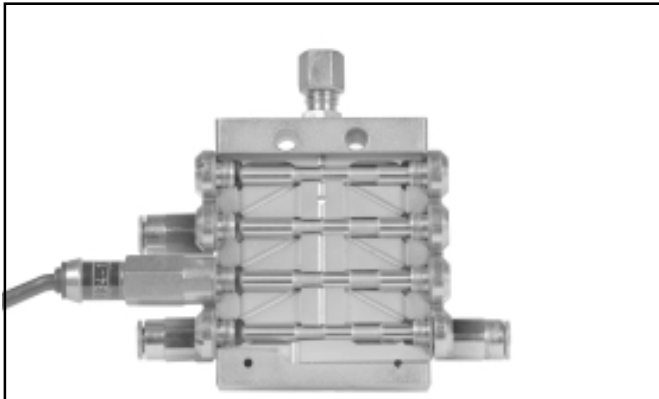

Fig. 3 - Sectional view of a SSV 8 metering device

Different of Features from SSV M - SSV

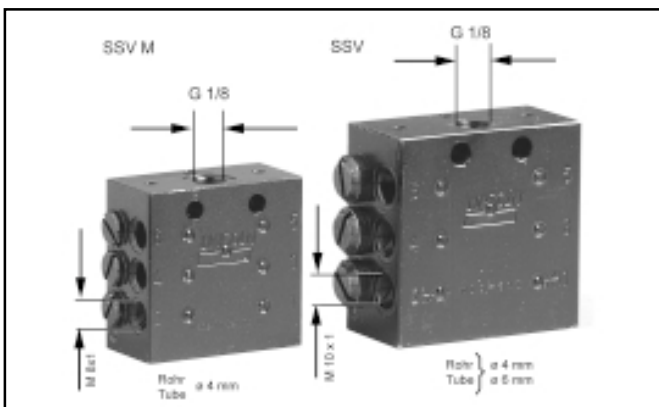

Fig. 4 - Differences between SSV M and SSV

NOTE: It must nevertheless be ensured that the oils or greases used do not alter their consistency significantly in the course of time or under the influence of temperature or pressure.

The progressive metering devices

- are piston-operated metering devices;
- automatically (progressively) dispense the lubricant fed by the pump to the connected lubrication points;
- **model SSV** have a **lubricant output of 0.2 cm³** per outlet and piston stroke;
- **model SSV M** have a **lubricant output of 0.07 cm³** per outlet and piston stroke;
- when one or more outlets are closed (see "Combining outlets") they can dispense a double or multiple lubricant quantity;
- are available with 6 to 12 outlets or up to 22 outlets;
- offer the option of combining several lubrication points into one centralized lubrication point.
- meter the supplied lubricant into predetermined single quantities.
- can be monitored visually (SSV and SSV M) or electronically (only SSV).
- Any blockage in a lubrication circuit is indicated by grease leaking from the respective pressure relief valve.

• The term "progressive" refers to the special features of the lubricant distribution within the metering devices, e.g.

- the successive movements of the individual pistons within the metering device due to the supplied lubricant being under pressure;
- the pistons move in a predetermined order and the cycles are repeated constantly;
- each piston must have completed its movement fully before the next piston can be moved, no matter whether the lubricant is dispensed continuously or intermittently;
- the pistons operate interdependently of one another;
- no lubrication point which is connected to the system is omitted.

Progressive divider valves **SSV M** and **SSV** operate in the **same way**. Apart from their outer dimensions (see below dimensions) they also differ in the following data (also see fig. 4).

SSV

Lubricant output per outlet and per stroke 0.2cm³
 Max. operating pressure 350 bar
 Min. operating pressure 20 bar
 Max. differential pressure
 between two outlets 100 bar
 Outlet connection for tube Ø 4 and 6 mm

SSV M

Lubricant output per outlet and per stroke 0.07cm³
 Max. operating pressure 200 bar
 Min. operating pressure 20 bar
 Max. differential pressure
 between two outlets 40 bar
 Outlet connection for tube Ø 4 mm

Applications

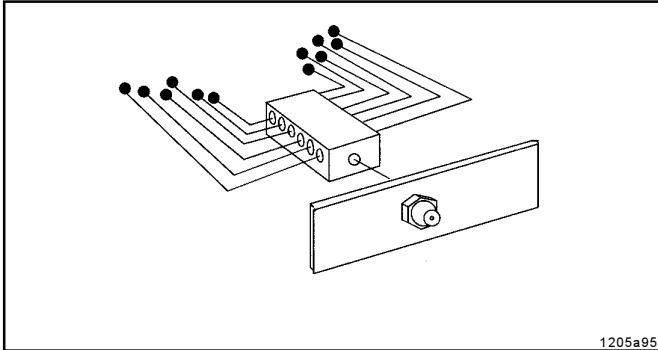

Fig. 5 - Central lubrication point

- QUICKLUB progressive metering devices offer the option of combining several lubrication points on a machine to one or more central lubrication points, as shown in Fig. 5 which illustrates this basic feature.

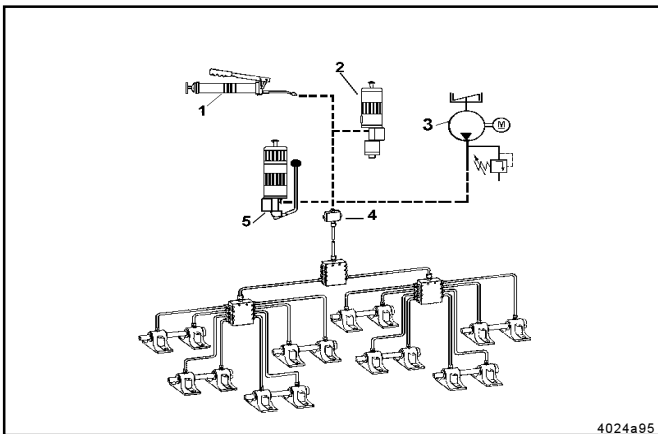

Fig. 6 - Possible pump connections

- When they are used in connection with hand-operated pumps, pneumatic or electric pumps the progressive metering devices are a simple and low-cost centralized lubrication system. See Fig. 6.

- 1 - Hand-operated pump
- 2 - Pneumatically operated pump
- 3 - Electrically operated pump
- 4 - Lubrication fitting block
- 5 - Hand-operated filling pump

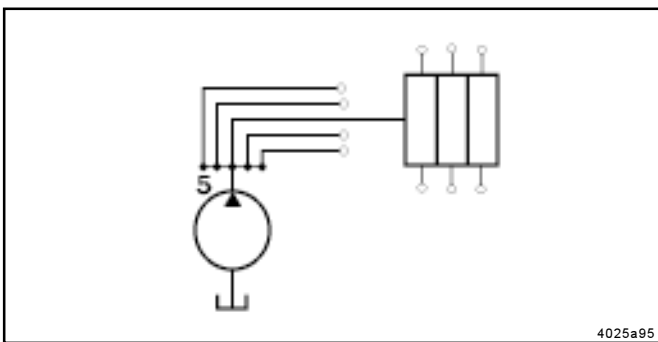

Fig. 7 - Multiline pump expanded by a progressive metering device

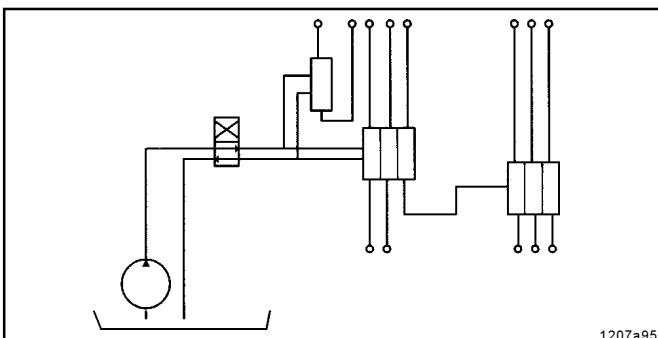

Fig. 8 - Two-line system expanded by a progressive metering device

- Progressive metering devices can be used in two-line or single-line centralized lubrication systems in order to increase the number of outlets of multiline pumps or to subdivide the single metering devices and measuring valves (Fig. 5 - 9) also as secondary metering devices in large and small oil circulating systems.

Subject to modifications

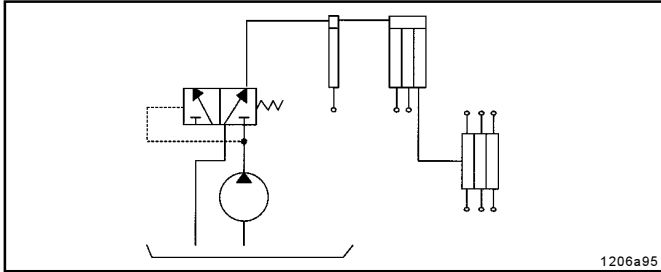

Fig. 9 - Single-line system expanded by a progressive metering device

Lubricant Distribution Within the Metering Device

- The 5 following illustrations show how the lubricant distribution is made to the individual outlets.

Note: To simplify the description we only show the lubricant distribution for outlets 2, 7, 5, 3 and 1. The remaining distribution operations are derived from the logical pumping sequence.

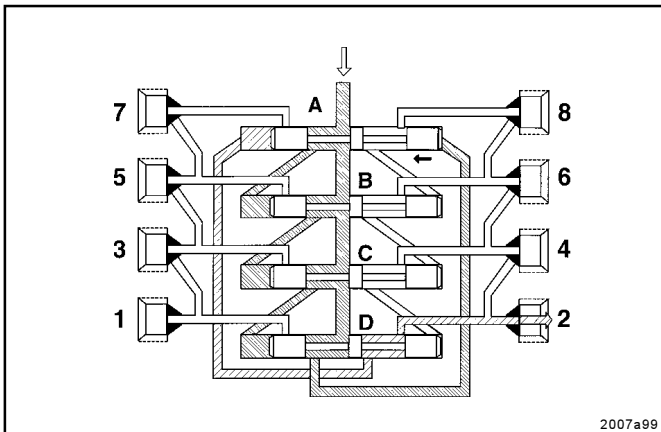

Fig. 10 - Phase 1

Phase 1

- The lubricant enters the metering device from above (white arrow) and flows to the right-hand end of piston A.
- Piston A (black arrow) is moved to the left under the pressure of the lubricant, causing the lubricant ahead of the left-hand end of piston A to be dispensed to outlet 2 (dashed arrow).



Lubricant under pump pressure



Lubricant under delivery pressure of the piston



Lubricant, pressureless

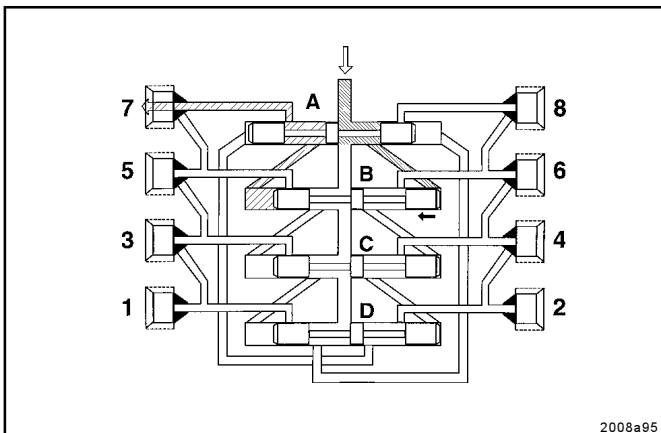

Fig. 11 - Phase 2

Phase 2

- Once piston A has reached its left-hand final position, the junction channel to the right-hand end of piston B is opened.
- The lubricant which arrives from above (white arrow) also moves piston B (black arrow) to the left, causing the lubricant quantity ahead of the left-hand end of piston B to be dispensed to outlet 7 (dashed arrow).



Lubricant under pump pressure



Lubricant under delivery pressure of the piston



Lubricant, pressureless

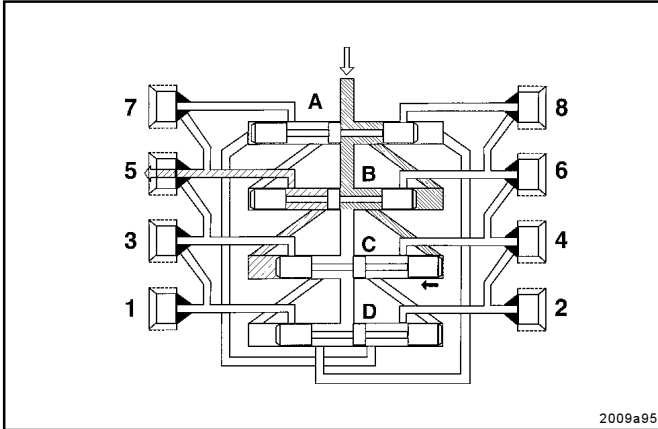

Fig. 12 - Phase 3

2009a95

Phase 3

- Once piston B has reached its left-hand final position, the junction channel to the right-hand end of piston A is opened.
- The lubricant which flows from above (white arrow) moves piston C (black arrow) to the left, causing the lubricant quantity ahead of the left-hand end of piston C to be dispensed to outlet 5 (dashed arrow).

- Lubricant under pump pressure
- Lubricant under delivery pressure of the piston
- Lubricant, pressureless

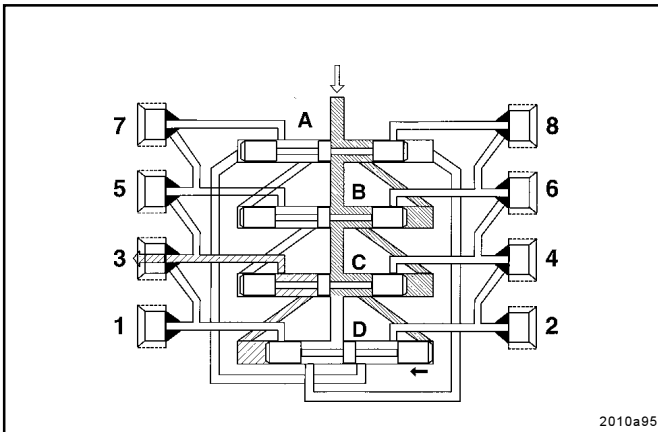

Fig. 13 - Phase 4

2010a95

Phase 4

- The channel to the right-hand end of piston D is now open (black arrow).
- The lubricant which is fed from above (white arrow) moves piston D to the left, causing the lubricant quantity ahead of the left-hand end of piston D to be dispensed out of the metering device via outlet 3 (dashed arrow).

- Lubricant under pump pressure
- Lubricant under delivery pressure of the piston
- Lubricant, pressureless

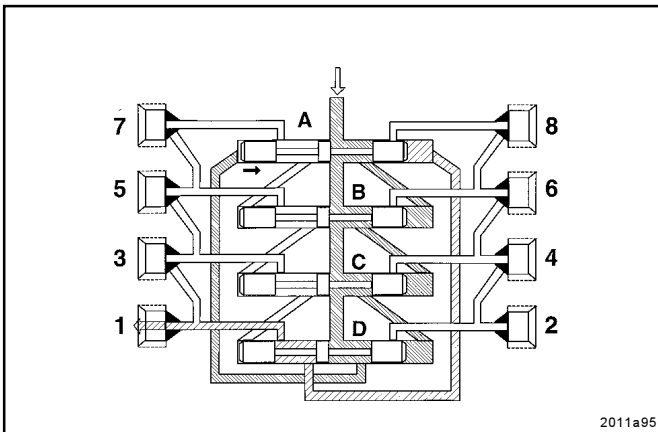

Fig. 14 - Phase 5

2011a95

Phase 5

- In phase 4, piston D had opened the junction channel to the left-hand end of piston A.
- The lubricant flowing in (white arrow) moves piston A to the right (black arrow), causing the lubricant quantity to be dispensed to outlet 1 (dashed arrow).
- In the subsequent distribution sequence, pistons B - D are moved from the left to the right one after the other.
- A complete distribution sequence is finished and a new cycle can begin.

- Lubricant under pump pressure
- Lubricant under delivery pressure of the piston
- Lubricant, pressureless

Subject to modifications

When the lubricant supply is interrupted

- the pistons come to a halt;
- the lubricant is no longer dispensed to the lubrication point.
- When the lubricant is fed again to the metering device, the cycle begins from the point where it had been interrupted.

Monitoring of the Operation

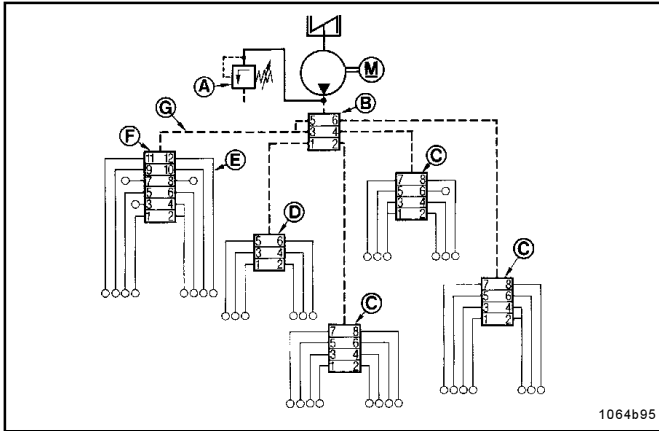

Fig. 15 - Example of a lubrication system

- | | |
|-------------------------------------|---|
| A - Safety valve | E - Pressure plastic tube (Ø 6 x 1.5 mm) |
| B - Main metering device SSV 6 | F - Secondary metering device SSV 12 |
| C - Secondary metering device SSV 8 | G - High pressure plastic hose (Ø 8.6 x 2.3 mm) |
| D - Secondary metering device SSV 6 | |

System-dependent monitoring

- The main metering device (B, Fig. 15) and the secondary metering devices are connected by a main line G. This feature automatically causes the linkage of the progressive system connected downstream of the pump.
- If only one piston does not move in any metering device or if the metering device can no longer dispense any lubricant via its outlets, this metering device will block itself.
- If one of the secondary metering devices is blocked, the main metering device is also blocked. The whole progressive system installed downstream of the pump stops operating.
- The fundamental internal structure of the progressive metering device guarantees the self-monitoring of the sequence within the metering device.
- The linkage makes it possible to monitor the operation of the whole system.

Visual monitoring

- The metering devices can be equipped with an indicator pin which is connected to the piston and moves back and forth during lubricant distribution.
- If there is a blockage in the system, the indicator pin stops moving.

Note: It is also possible to electrically check the movements of the indicator pin or any blockage in the system by means of a control switch (KS) or a proximity switch (KN).

Components of the control pin tube fitting

Closure plug M 11x1x5 MS, assy (pos. 1)	519-32123-1
consisting of of:	
Sealing ring 2x6.6x1.5 MS.....	306-17835-2
Screw M11x1x5.5 MS.....	303-19719-1
Screw ring M 10x1x0.7.....	303-17548-2
U-cup sealing ring G7 80 NBR 2x6.7x3.5x1.8.....	220-12512-1

Electrical monitoring (microprocessor control) SSV only

- A **piston detector** (initiator) which has been installed on a metering device instead of a piston closure plug (M 11 x 1) monitors the pump **operating time** and brings it to a close after all the pistons of this metering device have dispensed their lubricant quantity.
- If there is a blockage in the system or if the pump reservoir is empty, the piston detector can no longer record the piston movements. The switching off signal is not transmitted to the control unit. A fault signal occurs.

Important! For the system monitoring it is recommended that **one SSV metering device with pre-assembled piston detector** be used per lubrication circuit. These special metering devices must be ordered separately for each lubrication system. Refer to the Parts Catalog.

- The pre-assembled metering devices have the designation **SSV ... - N** (they are available for SSV 6, 8, 10, 12 and up to 22). They must be installed in the system instead of a normal metering device.

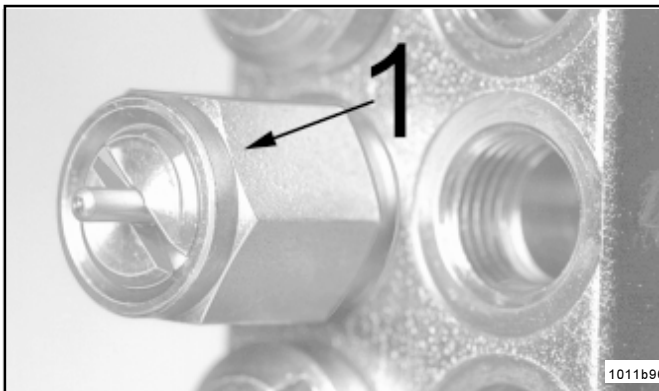

Fig. 16 - Indicator pin installed on metering device

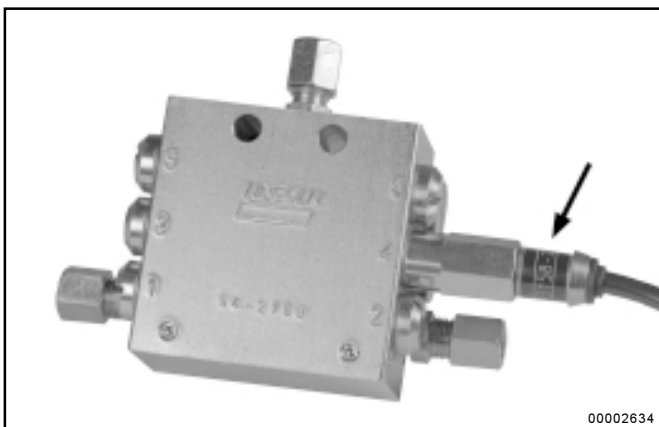

Fig. 17 - Piston detector installed on the metering device

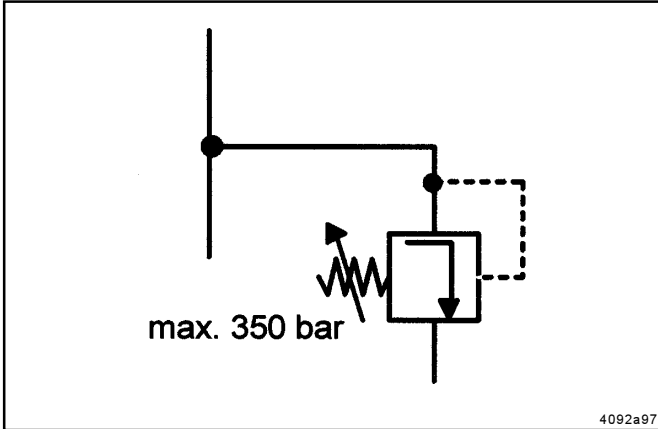

Fig.18 - Pressure relief valve

- The whole system can be monitored visually via the pressure relief valve. If lubricant is leaking at the pressure relief valve during the distribution sequence, this indicates that there is a blockage in the system.

Important: In the case of the progressive metering devices models SSV 6 - 22 the **outlets 1 and/or 2 must never be closed**. In the case of the assembled progressive metering devices model SSV 14 - 22, **the two outlets with the highest numbers must never be closed**, otherwise the system would block owing to the structure of the metering device.

Determining the Lubricant Output by Combining Outlets

Tube Fittings, Screw-Type

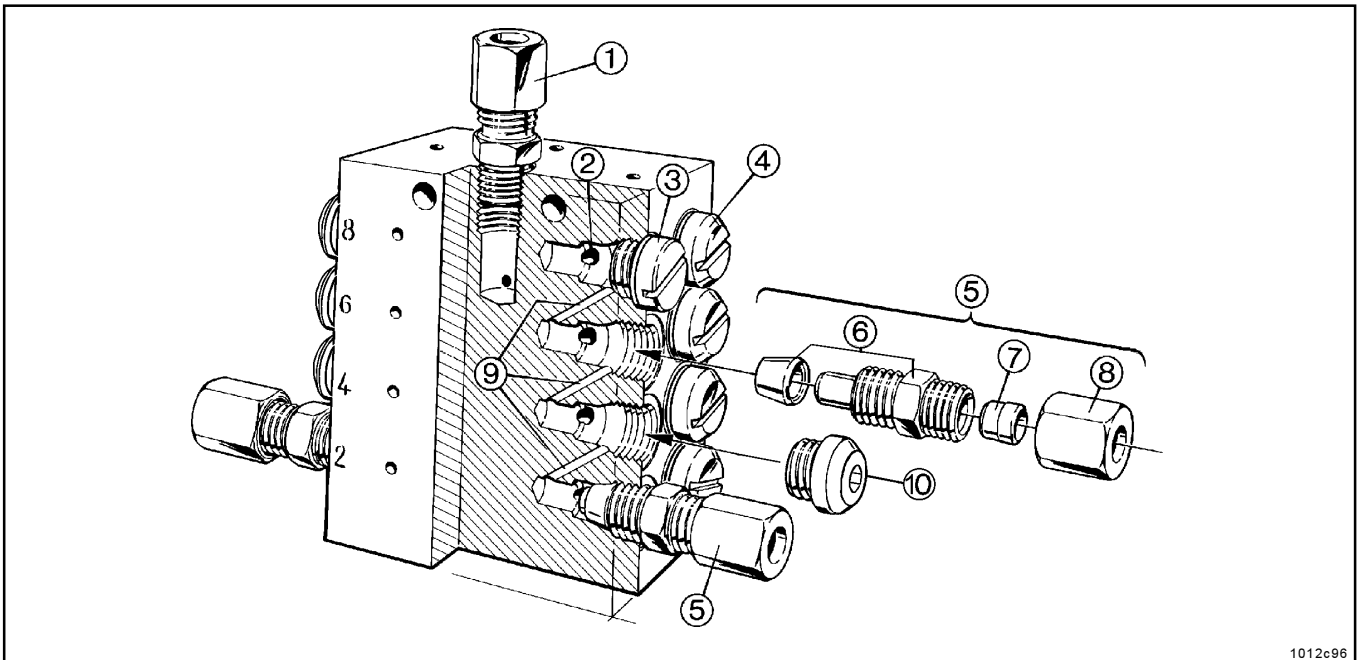

Fig. 19 - Install the outlet fittings and closure plugs in accordance with the dosage

Subject to modifications

- | | | |
|---|---|--|
| 1 - Inlet fitting | 5 - Outlet fitting assembly | 9 - Junction channel |
| 2 - Delivery hole of the piston | 6 - Valve body with clamping ring (brass) | 10 - New closure plug (M 10 x 1), outlet borehole with hex. socket head and sealing edge, replacement for pos. 3 |
| 3 - Closure plug (M 10 x 1), installed with copper washer (old) | 7 - Cutting ring | |
| 4 - Closure plug (new M 11 x 1), piston (with chamfered) | 8 - Coupling nut | |

- The output quantities can be raised by closing outlet boreholes.
- Install an outlet fitting assembly 5 (M 10x1) in each outlet borehole which will be used. Refer to Fig. 19, 20, 21.
- **Never remove closure plug 4** (M 11x1 chamfered) on the piston side or remove it only for installing a piston detector.

Note: Never use closure plug 12 (Fig. 19) or 7 (Fig. 20, 21) as a piston closure plug 4 (G 1/8) on older models of metering-devices.

- **Never use** closure plug 12 (Fig. 19) or 7 (Fig. 20, 21) **as a piston closure plug 4.**

Important: Always use valve body (Fig. 19) in conjunction with clamping ring.

- Clamping ring (Fig. 19) closes the junction channels 9 to the other outlet channels.
- Note: In the case of push-in type fittings the clamping ring is always a firm component part of the valve body.*

Important: In the case of the progressive metering devices **model SSV 6 - 22 the outlets 1 and/or 2 must never be closed.** In the case of the assembled progressive metering devices **model SSV 14 - 22, the two outlets with the highest numbers must never be closed,** otherwise the system would block due to the structure of the metering device.

Tube Fittings, Push-in-Type (main metering device)

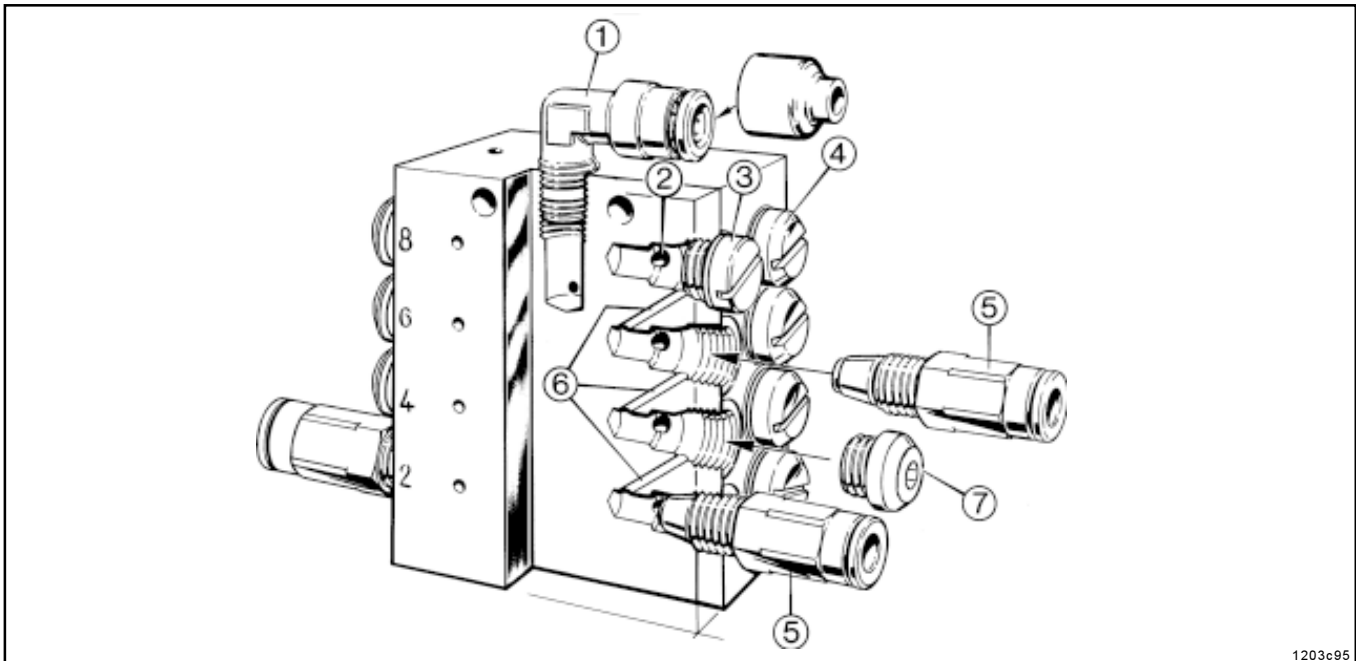

Fig. 20 - Install the push-in type outlet fittings and the closure plugs in accordance with the dosage

- 1 - Inlet fitting with protective cap *
- 2 - Delivery borehole of the piston
- 3 - Closure plug (M 10x1) with copper washer installed in outlet borehole (old)
- 4 - Closure plug (new M 11x1 chamfered), piston

- 5 - Valve body assembly (with reinforced collar)
- 6 - Junction channels
- 7 - New closure plug with hex. socket head and sealing edge, outlet borehole replacement for pos. 3

* on request

Tube Fittings, Push-in Type (secondary metering devices)

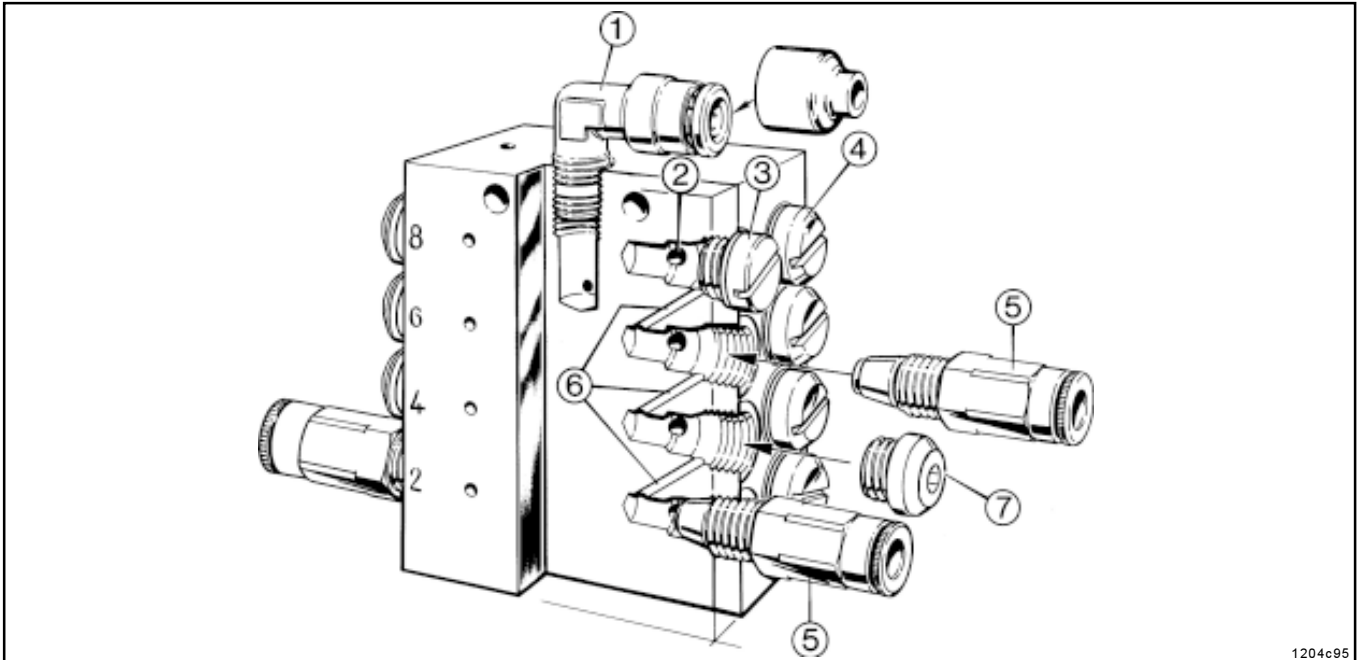

Fig. 21 - Install the push-in type outlets fittings and closure plugs in accordance with the dosage

- | | |
|--|--|
| <ul style="list-style-type: none"> 1 - Inlet fitting 2 - Delivery borehole of the piston 3 - Closure plug (M10x1) installed in outlet borehole with copper washer (old) | <ul style="list-style-type: none"> 4 - Closure plug (M11x1) (chamfered), piston 5 - Valve body assembly (with knurled collar) 6 - Junction channels 7 - New closure plug with hex. socket head and sealing edge, outlet borehole |
|--|--|

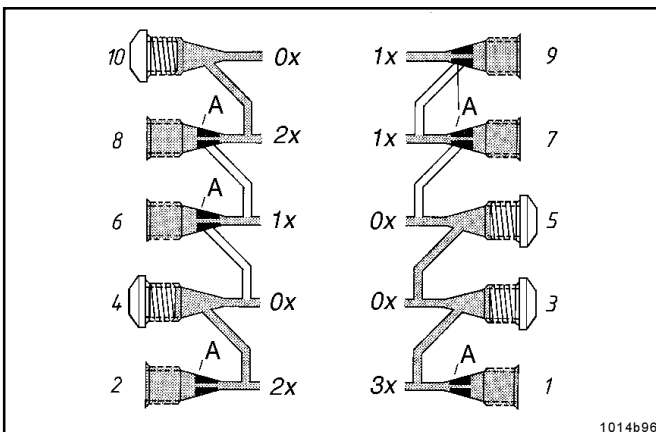

Fig. 22 - Single, double and triple lubricant output

- x - Outlet quantity (1x: single, 2x: double, etc.)
- 1... 10 Outlet numbers
- A - Clamping ring (brass)

Single lubricant output

- The simple lubricant output is the lubricant quantity dispensed by a piston per stroke and per outlet borehole to one lubrication point. **It amounts to 0.2 cm³ on SSV and 0.07 cm³ on SSV M.**

Double or multiple lubricant output

- If one or more lubrication points require a double or a multiple lubricant amount, this can be performed by closing one or more outlets.
- As shown in Fig. 22, outlet borehole 10 has been closed. The lubricant quantity supplied by this outlet flows out of the metering device via outlet 8.
- Total quantity at outlet 8:
 - is the quantity of outlet 8
 - plus the lubricant quantity of outlet 10.
- If a triple quantity is needed (at outlet 1), close the outlet borehole located above the discharge borehole. Refer to outlets 3 and 5 on Fig. 22.

Subject to modifications

Assembled Lubricant Metering Devices SSV 14 up to SSV 22, if equipped

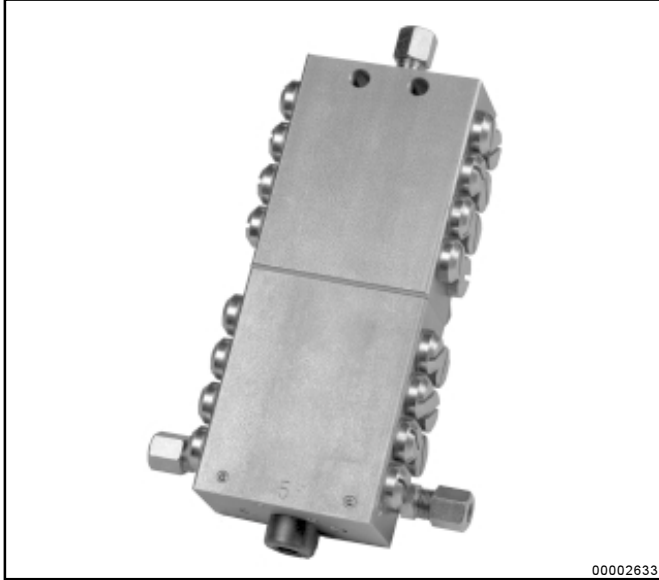

Fig. 23 - Lubricant metering device, assembled model SSV 16

- The assembled lubricant metering devices model SSV 14 to SSV 22
 - function in the same way as the metering devices model SSV 6 to SSV 12
 - are assembled from the basic metering devices SSV 6 to SSV 12.
- The following differences must, however, be noted:
 - the outlet numbers of the metering devices SSV 14 to SSV 22 are **marked in the opposite direction** to those of the SSV 6 to SSV 12 metering devices. Outlets 1 and 2 are close to the inlet borehole.
 - the two outlets -right-hand and/or left-hand - with the **highest numbers must never be closed**, otherwise the system would be blocked.
 - if, for example, outlet 8 is closed, the lubricant quantity dispensed to this outlet flows out of the metering device via outlet 10, etc. Refer to item "Double or multiple lubricant output" above.

Tube fittings, screw-Type

Main- and secondary Metering devices

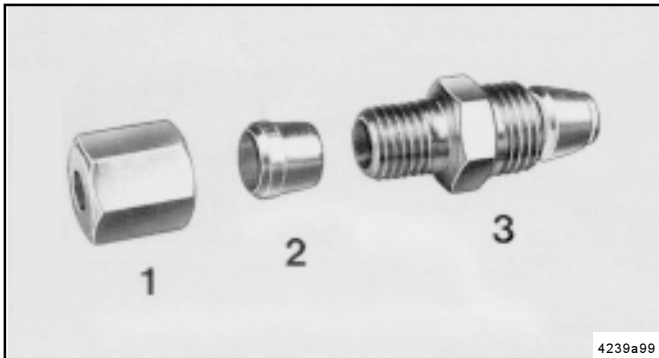

Fig. 24 - Single parts of the check valve

- 1 - coupling nut
- 2 - ferrule
- 3 - valve body with seal and clamp ring

Inlet tube fittings, straight and 90°

- As inlet fitting use only tube fittings R $\frac{1}{8}$ " thread.

Check valves

- Install one complete check valve in each outlet borehole which will be used.
- Install one closure plug in each outlet borehole which will be not used. **Exception:** outlet bore hole 1 and/or 2 on SSV 6 to SSV 22. In both boreholes check valves have to be installed.
- Check valves for tube dia. 4 mm and 6 mm are available.

Tube Fittings, Push-in Type

Metering Devices

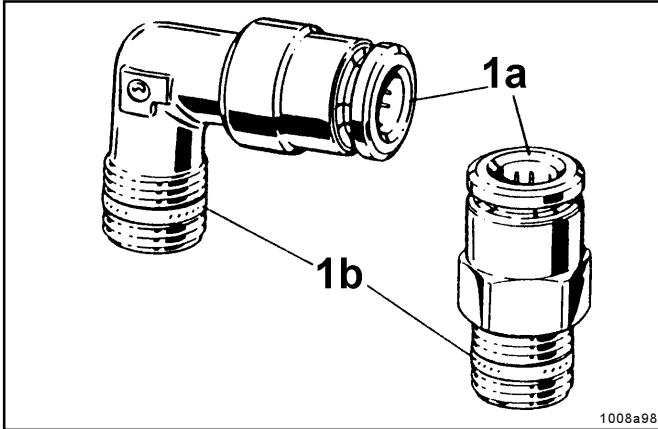

Fig. 25 - Inlet fittings

Inlet tube fittings, straight and 90 °

Important ! For the inlet fittings use only tube fittings with reinforced collet 1a (Fig. 25) and sealing ring 1b at the thread.

- 1a - Collet
- 1b - Sealing ring

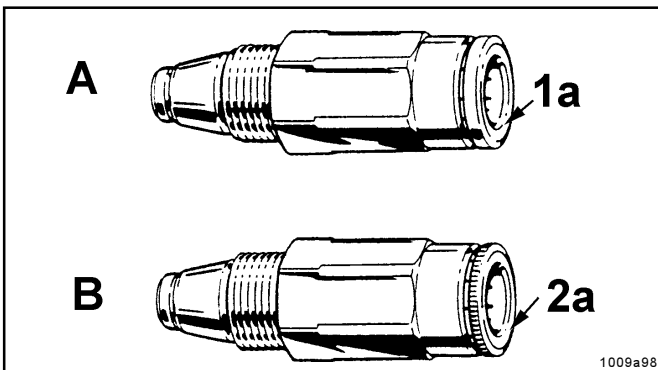

Fig. 25 - The different types of check valve

Check valves

- Main metering device
Use check valves type A, Fig. 26 with reinforced collet 1a and smooth flange (Part no. 226-14091-4).
 - Secondary metering device
Use check valves type B, Fig. 26 with standard collet 2a and knurled flange (Part no. 226-14091-2).
- Note: On construction machines or agricultural machines use high pressure plastic hoses. In such cases the check valves of the secondary metering devices must have a reinforced collet and smooth flange.*

- A - Check valve with reinforced collet
- B - Check valve with knurled collet
- 1a - reinforced collet
- 1b - knurled collet

Connection of the High-pressure Plastic Hose and the Pressure Plastic Tube



Fig. 27 - Check valve with reinforced collet and hose stud

High-pressure range (main metering device)

Important! Connect only main lines (\varnothing 8,4 x 2,3 mm) with threaded sleeve and hose studs may be connected to the inlet fitting and to the check valves with reinforced collar.

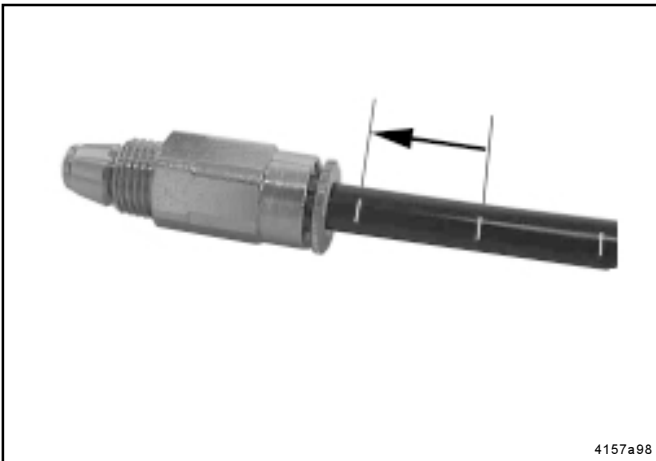

Fig. 28 - Check valve with knurled collet and pressure plastic tube

Low-pressure range (secondary metering device)

* Connect the pressure plastic tube (\varnothing 6x1.5 mm) to the check valve with standard collet (knurled collet) and to the inlet fittings towards the lubrication point (knurled collet).

Note: Exceptionally the high-pressure plastic hose (\varnothing 8.6 x 2.3 mm) with threaded sleeve and hose stud may also be used for the low-pressure section. Applications for construction machines or agricultural machines, however, require the use of check valves and inlet fittings (towards the lubrication point) with reinforced collet for the low-pressure range. Refer to Parts Catalog.

- The pressure plastic tubes are marked with white lines (Fig. 28) as an installation aid.
- * Cut the pressure plastic tube off at one of the white lines before it is mounted. Then insert the plastic pressure tube into the fitting up to the next white mark. This will ensure a correct installation of the pressure plastic tube in the threaded tube fitting.



Fig. 29 - Push-in type fitting with protection cap

Protection Cap for Push-in Type Fittings

To prevent dirt from entering the system, the push-in type fittings, check valves and pressure relief valves can be equipped with protective caps.

Pressure Plastic tubes and high-pressure plastic hoses

Pressure Plastic Tube $\varnothing 6 \times 1.5 \text{ mm}$

- Use the pressure plastic tubes only in the low pressure area, i.e. between the secondary metering devices and the lubrication point.
- Adhere to the pressures and bending radiuses mentioned in the chapter "Technical Data" when installing the parts.

High - pressure plastic hose $\varnothing 8.6 \times 2.3 \text{ mm}$

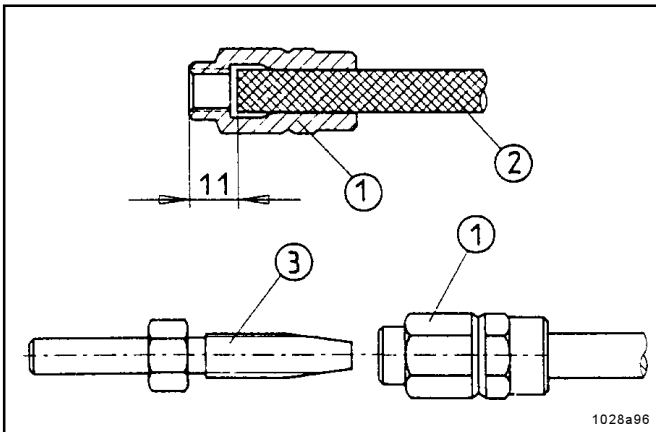

Fig. 30 - Preassembly of the threaded sleeves and hose studs on the main line

- 1 - Threaded sleeve
- 2 - High - pressure plastic hose $\varnothing 8.6 \times 2.3 \text{ mm}$
- 3 - Hose stud

- Use the high pressure plastic hose in the high-pressure area, i.e. between the pump, main metering device and secondary metering devices.
- Adhere to the pressures and bending radiuses mentioned in the chapter "Technical Data" when installing the parts.

Installing the threaded sleeves and hose studs on the high pressure plastic hose

- Screw the threaded sleeve, item 1 Fig. 30, counterclockwise onto the high pressure plastic hose 2 until the illustrated dimension of 11 mm is reached. Then screw the hose stud 3 into the threaded sleeve 1.

Important: Before screwing the parts 1 and 3, rub them with oil.

Note: The outside diameter of the main line may show variations in dimension. In such a case, press the threaded sleeve 1 at the end where it will be screwed onto the main line so that it becomes oval in shape (1 to 2 mm). This will prevent the high pressure plastic hose from being pushed out of the sleeve when the hose stud is screwed.

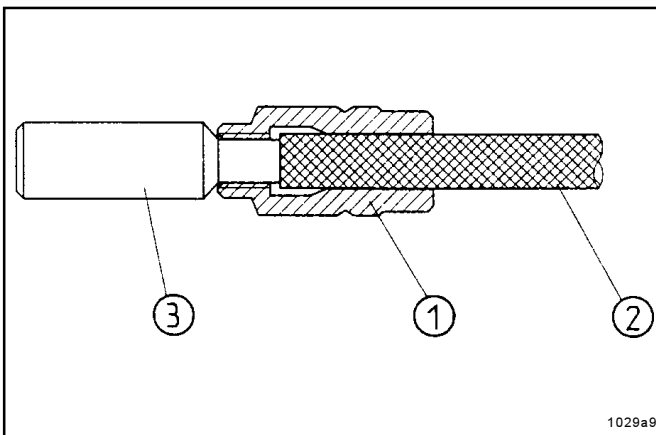

Fig. 31 - Preassembly of the threaded sleeve by means of an adjusting gauge

- 1 - Threaded sleeve
- 2 - High - pressure plastic hose $\varnothing 8.6 \times 2.3 \text{ mm}$
- 3 - Adjusting gauge 432-23077-1

Note: When using the special adjusting gauge 432-23077-1 (see Parts Catalog) screw the threaded sleeve counterclockwise onto the main line until the gauge inserted in the sleeve begins to rise.

Troubleshooting

• Fault: Blockage in the downstream progressive system

• Cause:

- Bearing, lines or metering device clogged.
- In the case of the metering devices SSV 6 through 22 the outlet boreholes 1 and/or 2 are closed. In the case of the assembled metering devices SSV 14 through 22 the two outlet boreholes with the highest numbers are closed.

The fault can be identified by:

- grease leaking at the safety valve;
- the fact that the indicator pins installed on the metering devices (if any) no longer move;
- the fault signal of the signal lamp (if any) or LED display

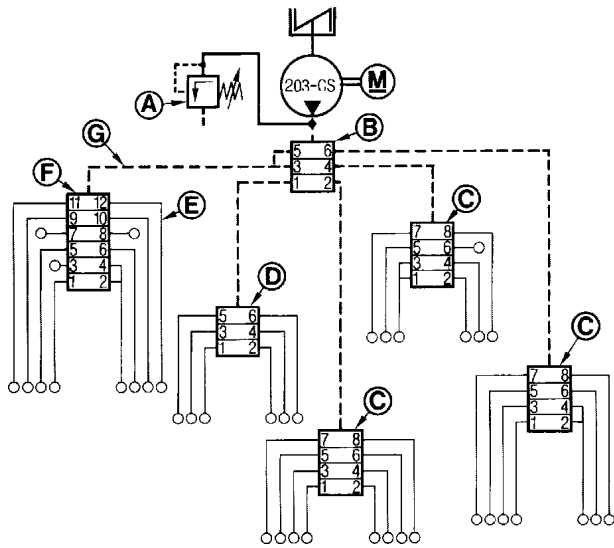

1064a95

Fig. 32 - Example of a lubrication system

- | | |
|-------------------------------------|--------------------------------------|
| A - Safety valve | E - Pressure plastic tubes |
| B - Main metering device | F - Secondary metering device SSV 12 |
| C - Secondary metering device SSV 8 | G - High-pressure plastic hose |
| D - Secondary metering device SSV 6 | |

• Correction:

- Find out which is the cause of the blockage and rectify it in accordance with the following example:

- Allow pump to run (see "To trigger an additional lubrication cycle").
- Loosen all main line connections G one after the other from the main metering device (B, Fig. 32) leading to the secondary metering devices. If f. ex. grease or oil emerges under pressure from outlet 1 of main metering device B, the blockage will be found in the lubrication circuit of the secondary metering device D.

Note: If there is a blockage in the downstream system, the main lines are under pressure. In such a case, it is difficult to detach the push-in type connecting parts of the main line. Relieve the system by removing the closure plug on the push-in type safety valve or, if any, by removing the filling nipple.

- Let the pump run.
- Disconnect all lubricant feed lines E from secondary metering device D one after the other. If f. ex. grease or oil emerges under pressure from outlet 3 of metering device D, the blockage will be found in the line of outlet 3 or in the connected bearing.
- Pump the blocked bearing or line through by means of a manual pump.

Note: When checking the individual outlets, keep each outlet loosened for quite a while because per each motor revolution there is only one piston stroke. A complete cycle of all metering devices requires several strokes.

- Check safety valve A. Replace it, if necessary.

<p>• Fault: Blockage in the downstream progressive system (continued)</p>	
<p>• Cause:</p>	<p>• Correction:</p>
<ul style="list-style-type: none"> • Metering device blocked 	<ul style="list-style-type: none"> • Replace the metering device or clean it in accordance with the following procedure: • Remove all tube fittings. • Unscrew the piston closure plugs. • If possible, try to eject the piston using a smooth drift (Ø smaller than 6 mm; 0.24 in.). • Important: The pistons are precision-fitted into the holes. Mark the pistons with regard to their installation position and direction after they have been removed. They must not be exchanged. • Thoroughly clean the metering device bodies in fat-dissolving washing agent, blow them through with compressed air. • Press free the slant ducts (Ø 1.5 mm; 0.59 in.) at the thread ends of the piston holes using a pin. • Clean the metering devices again and blow them through. • Reassemble the metering devices. • Replace the copper washers. • Before the tube fittings are reassembled, the metering devices should be pumped with oil several cycles by means of a manual pump. Check that the pressure in the metering device does not exceed 25 bar (362.8 psi). • If the pressure is higher, replace the metering device.
<p>• Fault: Differing lubricant amounts at the lubrication points</p>	
<p>• Cause:</p>	<p>• Correction:</p>
<ul style="list-style-type: none"> • Lubricant metering not correct • Respective valve body has been assembled without clamping ring • Setting of the pause time or operating time incorrect 	<ul style="list-style-type: none"> • Check the lubricant metering acc. to the lubrication chart • Remove the valve body and install a clamping ring • Check the time setting. Refer to the corresponding setting in the respective "Operating Instructions".
<p>• Fault: Over- or underlubrication of the lubrication points</p>	
<p>• Cause:</p>	<p>• Correction:</p>
<ul style="list-style-type: none"> • Setting of the operating time or pause time incorrect 	<ul style="list-style-type: none"> • Check the time setting at the printed circuit boards. Refer to the corresponding setting in the respective "Operating Instructions".

Planning and Layout

Instructions for QUICKLUB Progressive Systems

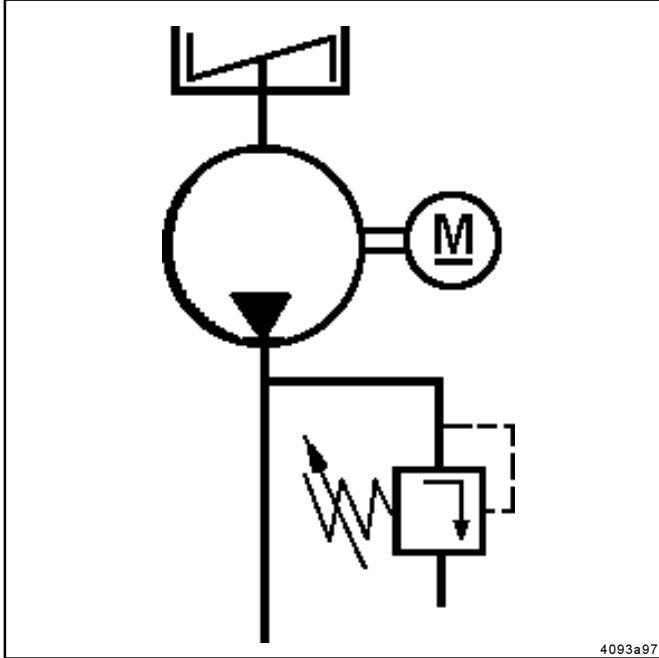

Fig. 33 - Selecting the pumps

To achieve the appropriate planning and layout of a system, you should observe the following rules:

1. Selecting the pump

- Select the pump in accordance with its application and lubricant requirement (2-l, 4-l or 8-l reservoir pump model 203 or 4-l, 8-l, 10-l or 30-l pump model 215)
- Adhere to the supply voltage of the drive motor.
- Select the printed circuit board or timer in accordance with the application. Note the application possibilities for the metering device monitoring.

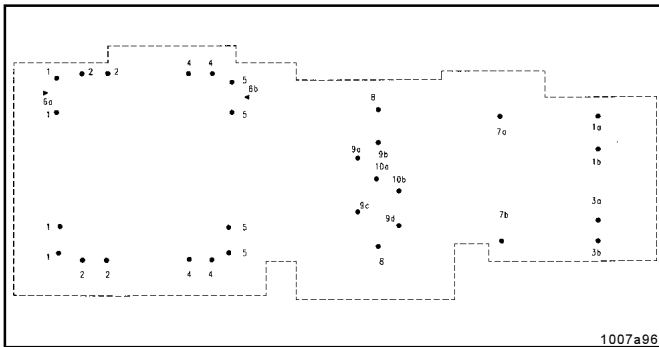

Fig. 34 - Determining the number of lubrication points

2. Determining the number of lubrication points to be connected

Exception: High-speed rotating parts. Also consider the lubrication points on auxiliary units or other superstructures.

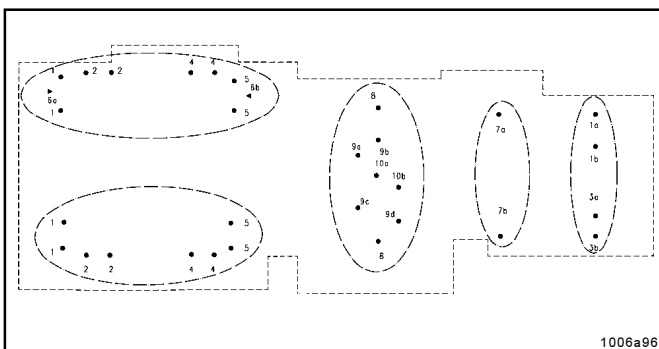

Fig. 35 - Combining the lubrication points into groups

3. Combining the lubrication points into groups

- A group should contain not more than 12 lubrication points, if possible fewer.
- If possible, also combine the lubrication points according to their lubricant requirement.

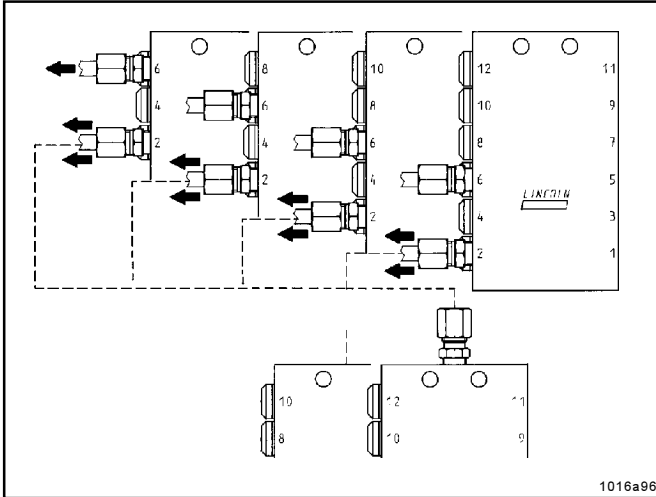

Fig. 36 - Adapting the lubricant quantities

4. Determining the lubricant requirement of the combined lubrication points

- The lubricant requirement depends on the design and operating conditions of the individual bearings.
- The lubricant quantities can be adapted to the requirement of the respective lubrication points by closing outlets (exception: outlet 1 or 2) of the metering blocks.
- Small bearings with or without sealing rings must always be supplied with a single lubricant quantity.
- Bigger bearings without sealing rings (length > 70 mm) or heavy duty bearings shall be supplied with a double or multiple lubricant quantity.

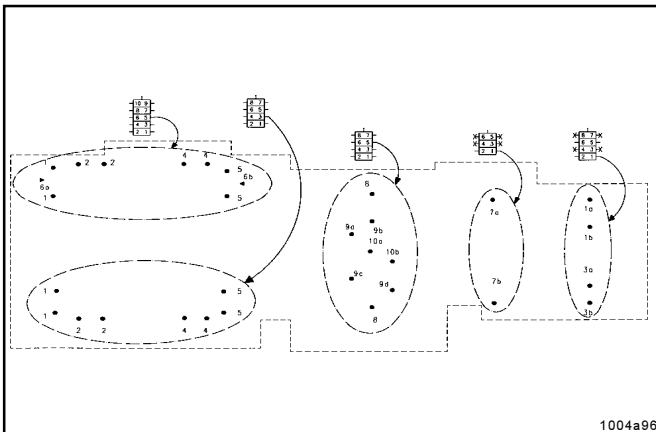

Fig. 37 - Allocating the metering devices

5. Allocating a metering device with the appropriate number of outlets to each group

- It is recommended that metering devices with 6, 8, 10 or 12 outlets be used, in special cases up to 22 outlets are possible.
- In the case of a monitored system, check where the metering device with the pre-assembled piston detector is to be used (as a main metering device or as a secondary metering device). The condition for this is that each lubrication point receives lubricant at least once per lubrication cycle.

Note: Metering devices with up to 22 outlets can be used in the case of special superstructures.

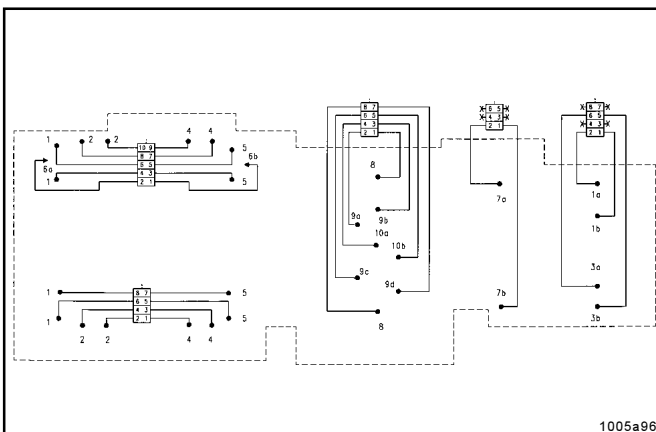

Fig. 38 - Connecting the metering device to the lubrication points

6. Connecting the metering device outlets with the lubrication points to be connected

Attention: In the case of the metering devices model SSV 6 to SSV 12 the outlets 1 and 2 must always be connected to a lubrication point.

In the case of the metering devices SSV 14 to SSV 22 the two outlets with the highest numbers (examples: 21 and 22 in the case of SSV22) must always be connected to a lubrication point.

Subject to modifications

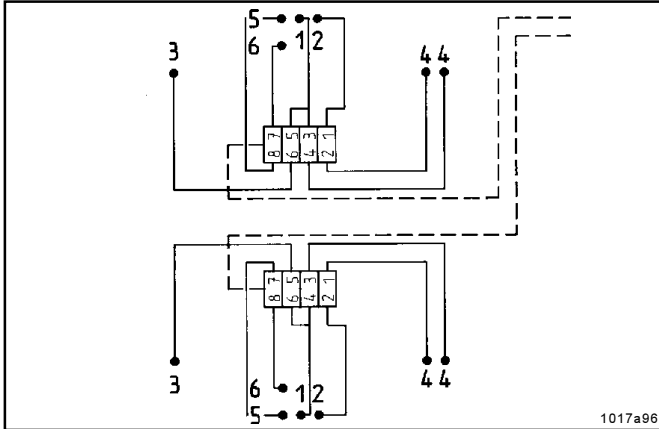

Fig. 39 - Allocating the lubrication points

- If there is an odd number of lubrication points or if the lubrication points require a large lubricant quantity, select the next larger metering device.
- Close the outlets which are not required (see Fig. 39, outlet 5 or 6), **except for outlets 1 and 2**.
- Outlets whose lubricant output is higher due to the closing of preceding outlets must be connected to the lubrication points with an increased lubricant requirement.

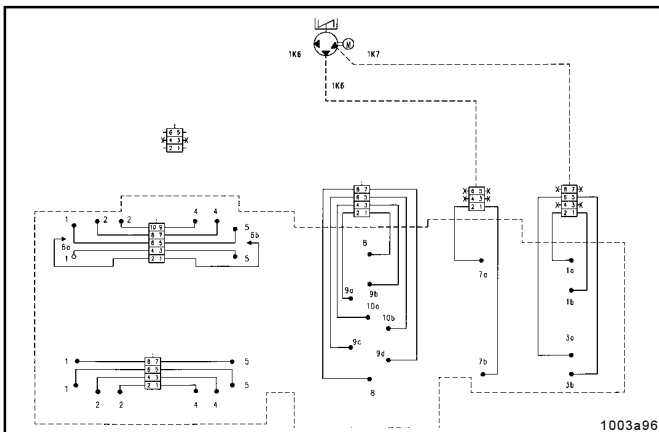

Fig. 40 - Determining the size of the main metering device

7. Determining the size of the main metering device

- First, allocate one outlet of the main metering device to each secondary metering device.
- If possible, supply the same lubricant quantities to similar lubrication points.
- Check whether one or more secondary metering devices require larger lubricant quantities. See direct connection of the metering device to respectively one single pump element, example Fig. 40.
- If necessary, modify the allocation of the lubrication points.
- Maximum size of the main metering device: SSV 12

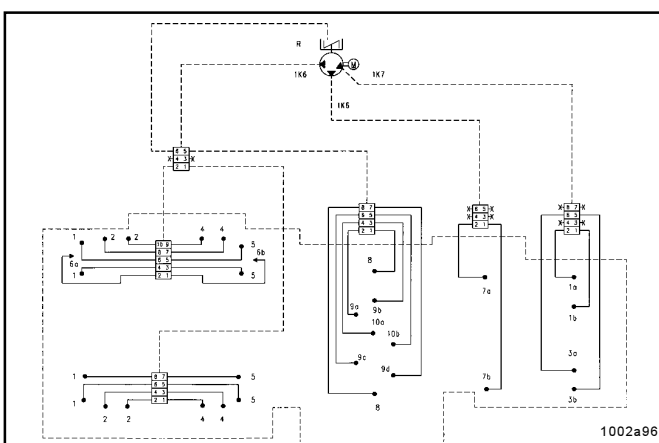

Fig. 41 - Divided lubricant quantity

8. Dividing the lubricant quantity

- Each lubrication point should be supplied with lubricant at least once every day, at the latest on the next day.
- Avoid overlubrication, i.e. too much lubricant per day and per lubrication point.
- Avoid underlubrication, i.e. too little lubricant per day and per lubrication point.
- To fulfill these conditions, adhere to the following:
 - Adjust the operating time in such a way that the pump supplies lubricant to the lubrication points at least once a day. See "Determining the operating time of the pump".
 - Adjust the pause time in such a way that the frequency of the lubricant supply meets the operating or application conditions of the machine or vehicle.
 - Divide the lubricant quantities as shown in the example Fig. 41. Also see the calculation example in Fig. 42.
- Connect the outlets of the main metering device which are not used to the pump via a return line R.

9. Lubricant output of the pumps 203* and 205**

- at 100 bar backpressure
- at 20°C
- at 24 V rated voltage

Pump element K5 **2 cm³/min***; **0.10 cm³/stroke****
 Pump element K6 **2.8 cm³/min***; **0.15 cm³/stroke****
 Pump element K7 **4 cm³/min***; **0.22 cm³/stroke****
 Adjustable pump element K7...**0.04 - 0.18 cm³/stroke* ****

Lubricant output of the pump 215

Max. number of outlets.....15

Lubricant output per piston stroke:

Pump element piston dia. 6 mm **0.10 cm³**
 Pump element piston dia. 7 mm **0.23 cm³**
 Adjusting range..... **25% to 100%**

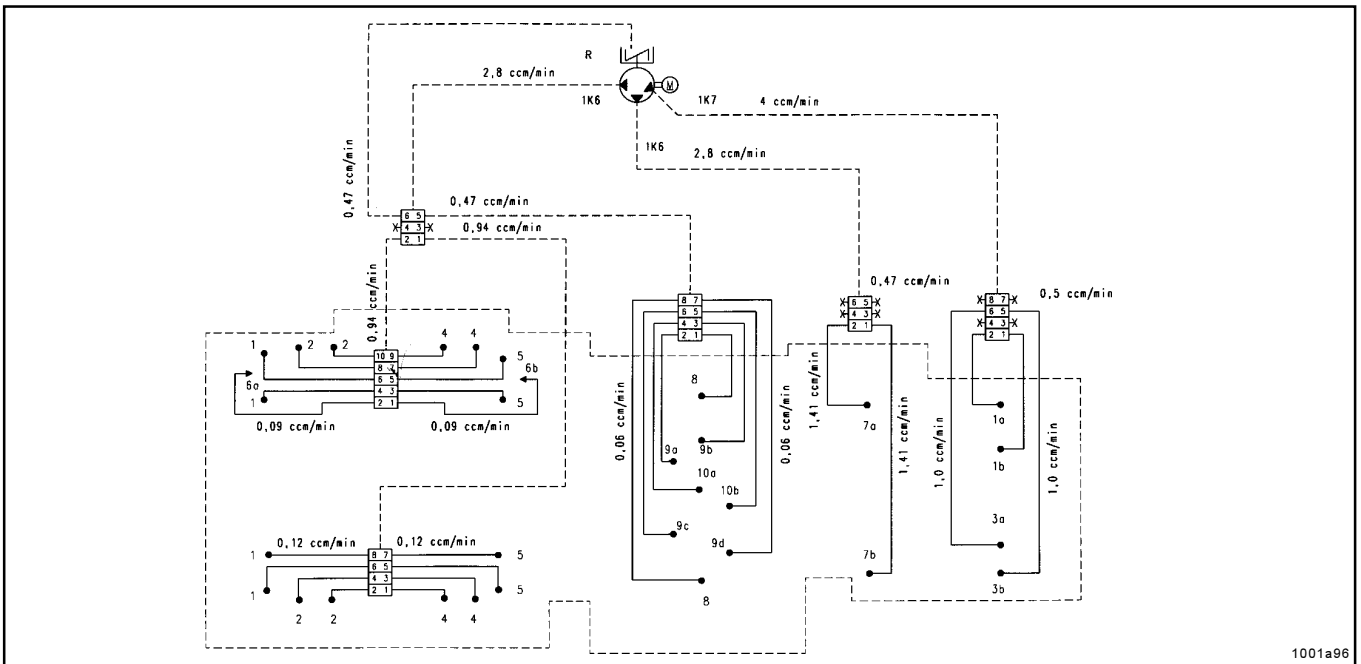

Fig. 42 - Dividing the lubricant quantity - Calculation example

10. Adjusting the running time (operating time) of the pump (not for pumps with microprocessor control)

- The chart below shows the required pump operating times in the case of various combinations of the main metering device and the **biggest secondary metering device**.
- With the **indicated times** each lubrication point receives lubricant at least **once a day**.

- For the running time of a system select the time for the biggest secondary metering device, as a function of the main metering device used.
- If the time mentioned below cannot be preselected, take the next larger time value.

Required minimum running times (pump element K6)								
Main metering device	SSV 6		SSV 8		SSV 10		SSV 12	
Lubricant output of the main metering device	Single	Double	Single	Double	Single	Double	Single	Double
Secondary metering device								
SSV 6	3 min	-	4 min	-	5 min	-	6 min	-
SSV 8	4 min	-	5,5 min	-	6,5 min	-	8 min	-
SSV 10	5 min	2,5 min	6,5 min	3,5 min	8,5 min	4,5 min	10 min	5 min
SSV 12	6 min	3 min	8 min	4 min	10 min	5 min	12 min	6 min

Subject to modifications

- During the operating time (pump running time) the used lubricant is renewed or topped up in the bearings.
- The frequency of renewal/topping up and the quantity which must be supplied to a single lubrication point depends on several factors, e.g.:
 - bearing size
 - kind of bearing - open or closed bearing, rolling bearing or friction bearing
 - frictional force
 - bearing loads
 - adjustable running times of the pump, etc.
- The required quantity may be very different as a result of the above mentioned factors.

It is **important** to take care that the lubricant is renewed or topped up within a predetermined time of application of the machine or vehicle so that there is no damage to the bearings.

If **normal or larger bearings** are connected to the secondary metering devices model SSV 10 or SSV 12 or up to SSV 22, these metering devices must receive **the double or multiple quantity**.

In the case of smaller bearings with a small lubricant requirement the SSV 10 or SSV 12 will receive a **single lubricant quantity**.

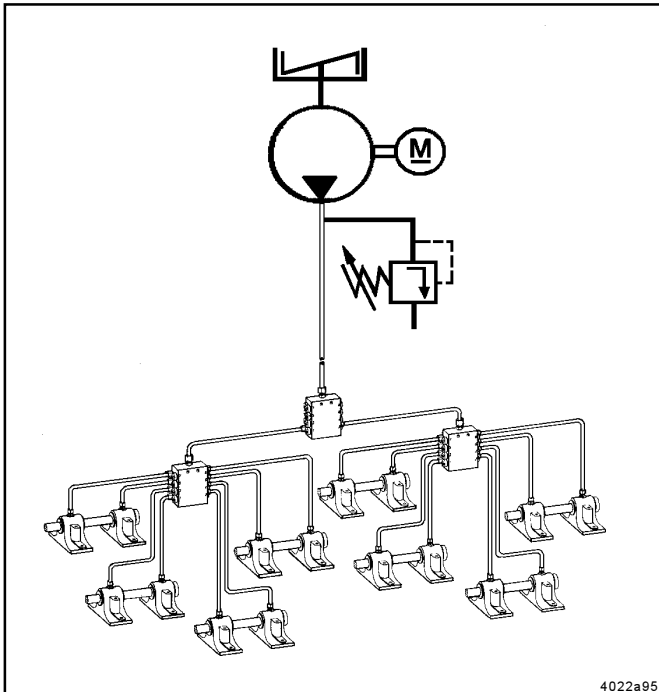

4022a95

Fig. 43 - Example of connection for machine bearings

11. Connecting machine bearings

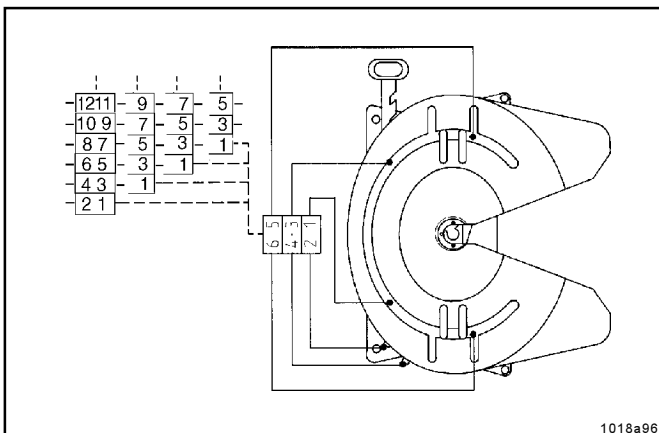

1018a96

Fig. 44 - Fifth-wheel with 6 lubrication points

12. Connecting a fifth-wheel

- Fifth-wheels must be supplied from the main metering device with a **double quantity**.

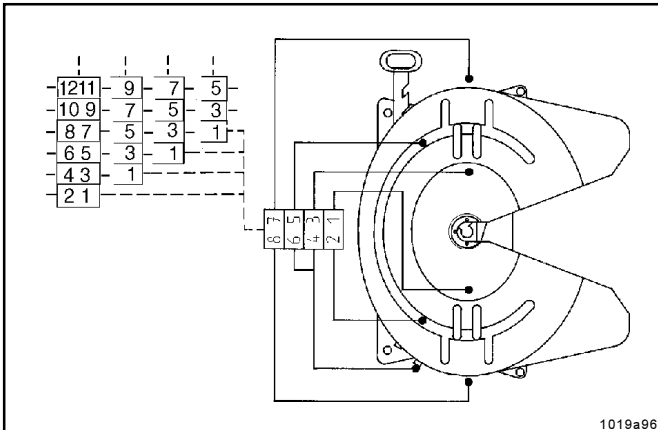

Fig. 45 - Fifth-wheel with 7 lubrication points

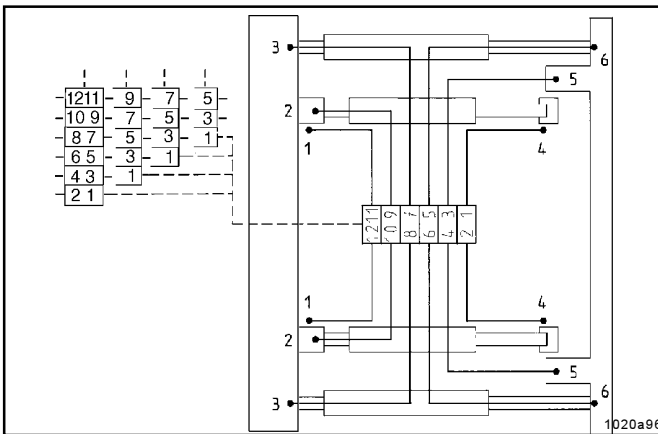

Fig. 46 - Liftgate with 12 lubrication points

13. Connecting a liftgate

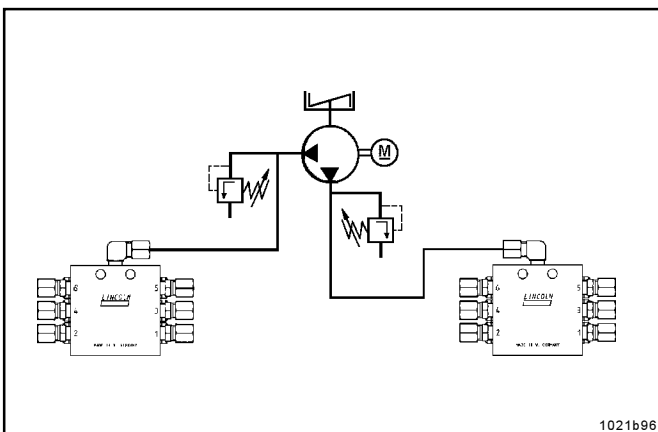

Fig. 47 - System using two pump elements

14. Using a second pump element (2nd lubrication circuit)
If the vehicle chassis or the machine is already equipped with a centralized lubrication system and if a superstructure (e.g. crane) or an auxiliary unit must be connected subsequently, this superstructure or auxiliary unit can be supplied from a specially installed pump element.

Important: Each pump element must be equipped with a safety valve.

15. Maximum line lengths

Important: The lubricant division should be made only via 2 steps of metering devices, i.e. **main metering device - secondary metering device - lubrication point**

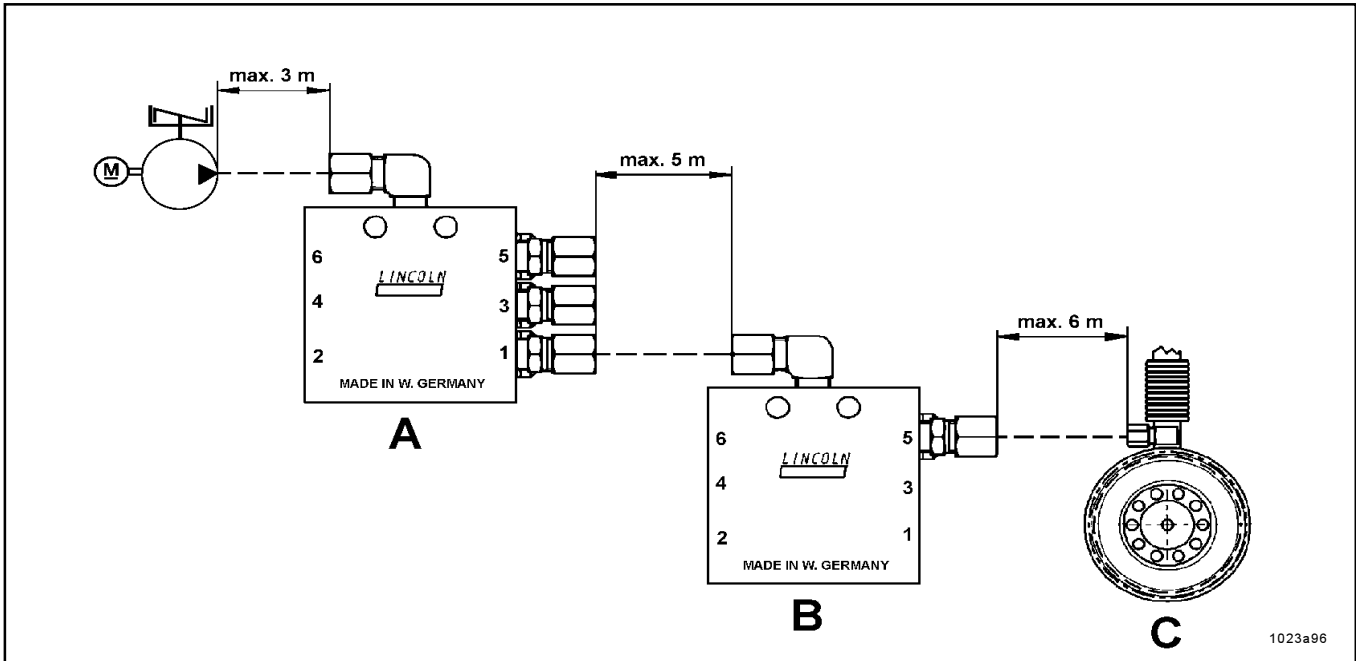

Fig. 48 - Maximum line lengths

- A - Main metering device
- B - Secondary metering device
- C - Lubrication point

16. Pressure losses

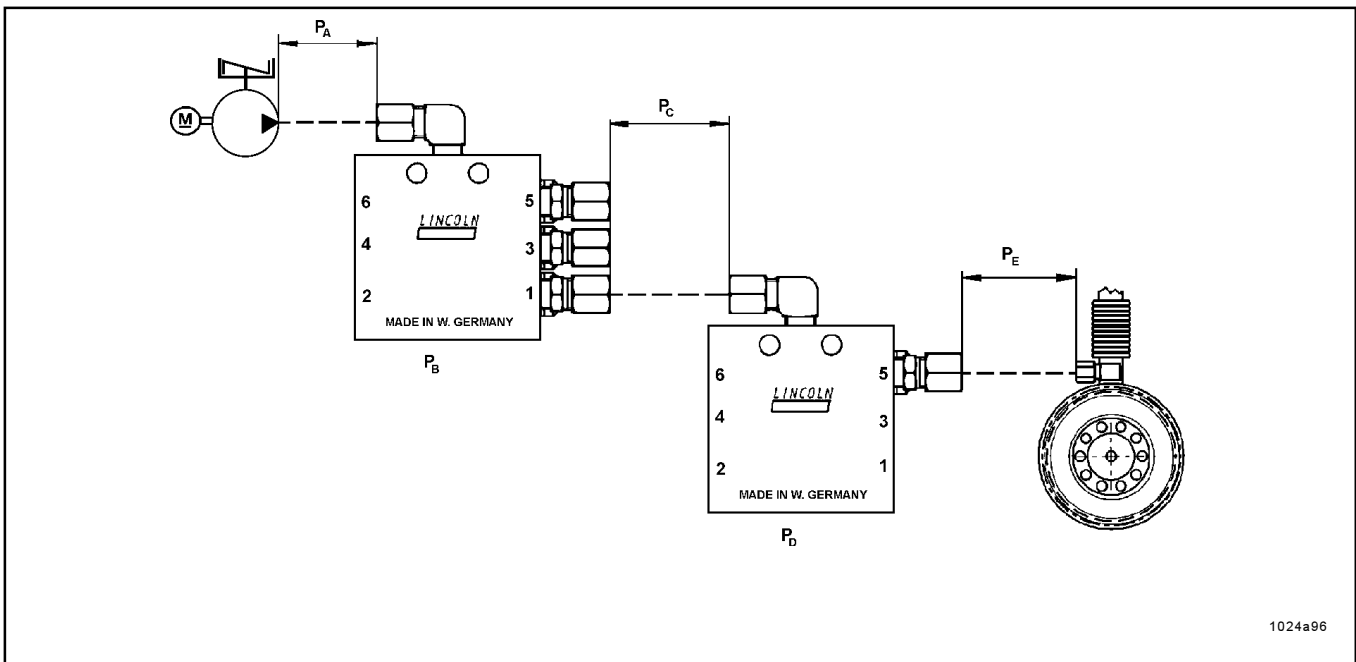

Fig. 49 - Pressure losses in the metering devices or tube lines

- P_A Pressure loss, main line
- P_B Pressure loss, main metering device

- P_C Pressure loss, main line between main and secondary metering device

- P_D Pressure loss, secondary metering device
- P_E Pressure loss, lubricant feed line

Subject to modifications

The following chart serves as a reference when calculating the maximum size of a QUICKLUB system, under consideration of the lubricant sorts and ambient temperature.

Lubricant penetration class		Maximum pressure loss with tube 6x1,5 mm (NW 3 mm)		
Temperature	0° C	15° C	25° C	
NLGI 0	5 bar/m	4 bar/m	2,5 bar/m	
NLGI 1	8 bar/m	7bar/m	5 bar/m	
NLGI 2	12 bar/m	8 bar/m	6 bar/m	
Maximum pressure loss through each SSV 6 to SSV 12				
NLGI 0	20 bar	15 bar	10 bar	
NLGI 1	25 bar	20 bar	15 bar	
NLGI 2	30 bar	25 bar	20 bar	

Note: The data relating to the pressure loss per metering device refer to metering devices with 6, 8, 10 and 12 outlets, namely the main and secondary metering devices.

- The sum of all pressures, from PA to PE plus 5 bar for the rolling bearings (lubrication point) or plus 15 bar for friction bearings must not exceed 80% of the recommended working pressure of the pump.
- All the values mentioned in the tablet are average values based on real test results.
- The NLGI class of the grease only indicates the statistical density. It does not indicate the dynamic pumpability of the grease. The flow properties of greases of the same NLGI class may be very different.

Technical Data

Metering Device Model SSV

Lubricant output per outlet and per stroke.....0.2cm³
 Max. operating pressure 350 bar
 Min. operating pressure..... 20 bar
 Max.differential pressure
 between two outlets 100 bar
 Outlet connection for tube..... Ø 4 and 6mm
 Inlet connection..... G 1/8
 Operating temperature..... - 25° C to 70°C

Metering Device Model SSV M

Lubricant output per outlet and per stroke..... 0.07cm³
 Max. operating pressure 200 bar
 Min. operating pressure..... 20 bar
 Max.differential pressure
 between two outlets 40 bar
 Outlet connection for tube..... Ø 4mm
 Inlet connection..... G 1/8
 Operating temperature..... - 25° C to 70°C

Screw-Type and Push-inType Tube Fittings

High pressure range, p max. 350 bar
 Inlet tube fittings of the metering devices
 Outlet fittings, main metering device
 Low-pressure range, p max. 250 bar
 Outlet fittings, secondary metering devices
Inlet fittings to the lubrication point

Lines

MainLine

Min. bursting pressure (in connection with
 hose clamp, screwed). 600 bar
 Min. bending radius. 35 mm
 Min. temperature..... - 40° C

Lubricant Feed Line

Min. bending radius..... 50 mm
 Bursting pressure at 20° Capprox. 210 bar
 Min. temperature..... - 40° C

Tightening torques

Closure plug (piston) in metering device	10 Nm	Compression nut onto inlet fitting	10 Nm
Closure plug (outlets) in metering device	10 Nm	Compression nut onto outlet fitting, screw-type	
Inlet fitting in metering device		plastic tube	5 Nm
screw-type	17 Nm	steel tube	10 Nm
plug-type	10 Nm	Control pin in metering device	12 Nm
Outlet fitting in metering device		Piston detecteur in metering device	12 Nm
screw-type	10 Nm	KN - switch on metering device	12 Nm
plug-type	8 Nm	Install metering device	10 Nm

Dimensions

Metering Devices Model SSV 6 to SSV 22
(Blocks)

Metering devices SSV 14 ... 22 (assembled)

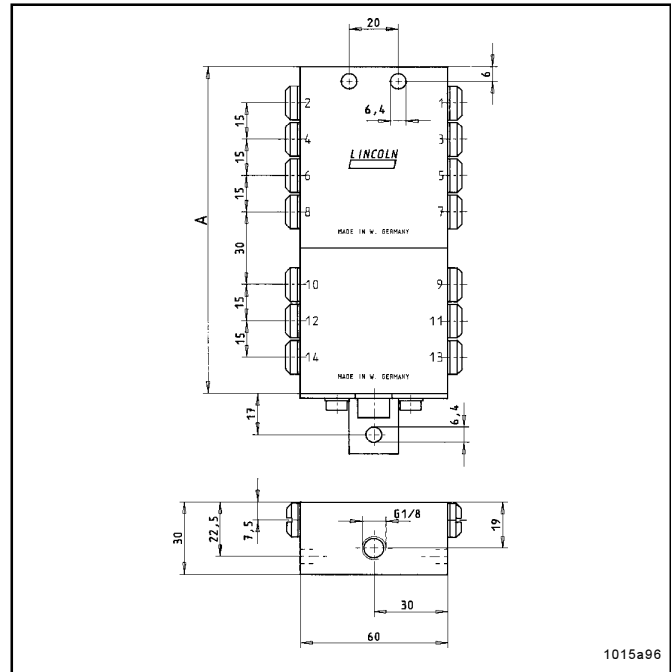
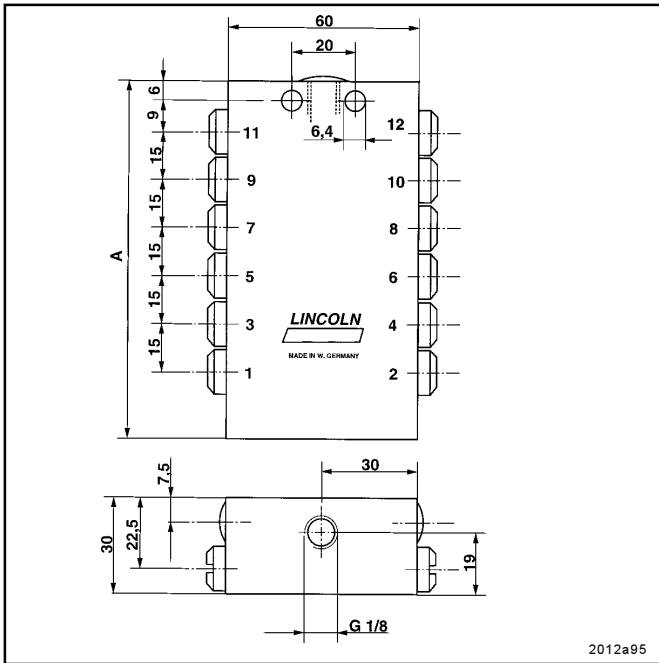

Model SSV	Dimensions A in mm
6	60
8	75
10	90
12	105
14	120
16	135
18	150
20	165
22	180

Model SSV	Dimensions A in mm
14	135
16	150
18	165
20	180
22	195

Metering Devices Model SSV M 6 to SSV M 12

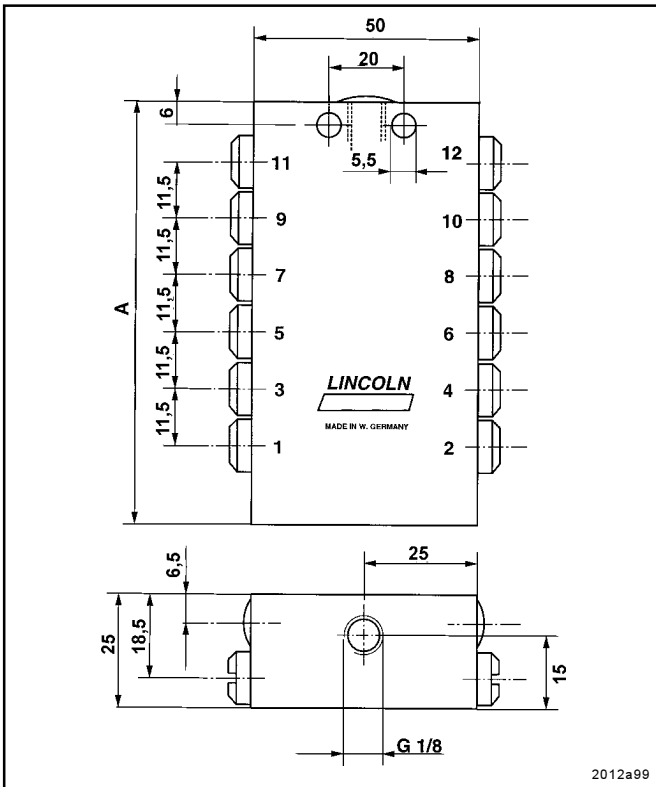

Model SSV M	Dimensions A in mm
6	48,5
8	60
10	71,5
12	83

Lubricants

Important: The manufacturer of the centralized lubrication system tests the lubricants **exclusively** on their **transportability in the centralized lubrication systems**, not on their compatibility with other material. The lubricants tested did not cause any damage due to incompatibility on the material used by us. The composition of the lubricants, their behavior during the transport and their compatibility with other material are not known to us. **Lubricant recipes may change.** In case of doubts, send your request for more information to the manufacturer of the centralized lubrication system.

- The manufacturer of the centralized lubrication system can accept no liability for:
 - damages on parts of the centralized lubrication system caused by chemical or biological changes of the lubricant used
 - damages due to the use of greases that are not or only conditionally transportable in centralized lubrication systems.

Important: The lubricants released by us have not been tested with regard to their long-term behavior. Therefore, we can give no guaranty for damages caused by chemical reactions of the lubricant with components of the centralized lubrication system.

Lubricants (Cont.)

The QUICKLUB pump 203 can dispense greases up to NLGI class 2 or mineral oils with min. 40 mm²/s (cST) at 40°C.

Important: Absolute cleanliness is essential when handling lubricants. Impurities will remain suspended in the lubricant and cannot settle. This will block the delivery channels causing damage to the bearings.

Recommended grease for QUICKLUB systems down to -25 °C

Manufacturer	Type	Base soap	Min. delivery temperature
AGIP	F1 Grease	Ca	
ARAL	Multipurpose grease ZS 1/2	Ca/Li	-20° C
AUTOL	Top 2000	Ca	-10° C
AUTOL	Top 2000 W	Ca	-20° C
BP	Lubricating grease	Ca	
BP	C1 lubricating grease	Ca	
CASTROL	CL grease	Ca/Li	
ESSO	Cazar K2	Ca	
ESSO	High pressure grease	Ca	
FIAT LUBRIFICANTI	Comar 2	Li	-25° C
FINA	Ceran LT	Ca	-20° C
FINA	Cera WR2	Ca	
FUCHS	FN 745	Ca	-25° C
FUCHS	Renocal FN 3	Ca	-20° C
FUCHS	Renolit HTL 2	Li	-25° C
MOBIL	Mobilgrease 28	Li	-30° C
MOLYKOTE	TTF 52	anorg thickener	-30° C
OPTIMOL	Longtime PD 2	Li	-20° C
OPTIMOL	Olit CLS	Li/Ca	-15° C
SHELL	Retinax C	Ca	
WESTFALEN	Greasalit ZSA	Li	-20° C
ZELLER & GMEHLIN	ZG 450	Li	
ZELLER & GMEHLIN	ZG 736	Li	

Biodegradable

Manufacturer	Type	Base soap	Min. delivery temperature
ARAL	BAB EP 2	Li/Ca	
AUTOL	Top 2000 Bio	Ca	-25° C
AVIA	Biogrease 1	Li	bis 0° C
DEA	Dolon E 2	Li	-15° C
FUCHS	Platogel S2	Li/Ca	
KLÜBER	Klüberbio M 72-82	Li	-20° C