

Printed Circuit Board 236-13870-1 ***Models : "M 16 - M 23"***

for Metering Device Control (microprocessor control)
Industrial Applications



Subject to change without notice

10041327

Survey

Pump	Voltage [V]	Control unit	Setting ranges	Part no.	Applications
203	12/24	integrated F **, **	P : 6 hours, fixed A : 2 to 30 minutes	236-13856-1	
		integrated F **, ** V 00-V03	P 1 : 3.75 to 56.25 minutes P 2 : 1 hour to 15 hours A 1 : 7.5 seconds to 112.5 seconds A 2 : 2 to 30 minutes	236-13862-1	
		integrated M 00-M 03***	P : 4 to 60 minutes P : 1 to 15 hours Ü : 5 or 30 minutes	236-13870-1	
		without control unit or with external control unit*			
203	12/24	integrated F **, **ADR V 00-V 03**, ** ADR		236-13859-1 236-13862-1	
203	12/24	integrated H *	B : 6 hours, fixed A : 2 to 30 minutes	236-13857-1	
203	12/24	integrated H * ADR	B : 6 hours, fixed A : 2 to 30 minutes	236-13857-1	
203	24 VDC	external PSG 01	P : 0.5, 1, 2...to 12 hrs A : 2, 4, 8, 16, 32 min	236-13834-1 664-36875-1	
203	24 VDC, 115 VAC, 230 VAC	external PSG 02	P : 1 min to 160 hrs A : 1 min to 160 min Ü : 1 min to 160 min	236-13860-2	

A - Operating time ranges B - Time of availability

P - Pause time range

Ü - Monitoring time

* 1A1 - Version - Pump without connection for the illuminated pushbutton

**2A1 - Version - Pump with connection for the illuminated pushbutton

***2A4 - Version - Pump with microprocessor control

Note: The applications of the progressive systems are various. There is therefore a corresponding control unit available for each individual application.

Subject to change without notice

Table of Contents

	Page		Page
Survey	2	Time setting.....	10
Printed circuit board M 16 - M 23	4	Test run /To trigger an additional lubrication.....	11
Applications.....	4	Repair.....	11
Advantages.....	4	The faults and their causes	12
Power supply.....	5	Fault indication.....	12
Mode of operation.....	6	Troubleshooting.....	13
Pause time.....	7	Technical data	13
Operating time.....	8	Connection diagram.....	14
Monitoring time.....	8	Combinations of the jumper positions.....	15
Functional check.....	8		
Funktion of the Push.....	9		
To remedy to a fault.....	.9		

Further information can be found in the following manuals:

Technical Description Pump Model 203
Technical Description Progressive Metering Devices for Grease and Oil, model SSV
Technical Description for "Electronic Control Units" of the model 203 pump
Printed Circuit Board 236-13856-1, Model F
Printed Circuit Board 236-13862-1, Model V 00-V 03
Printed Circuit Board 236-13857-1, Model H
Printed Circuit Board 236-13870-1, Model M 00 - M 15
Timer 236-13860-2, Model PSG 02
Installation Instructions
Parts Catalog

Printed Circuit Board , M 16 - M 23*

Applications

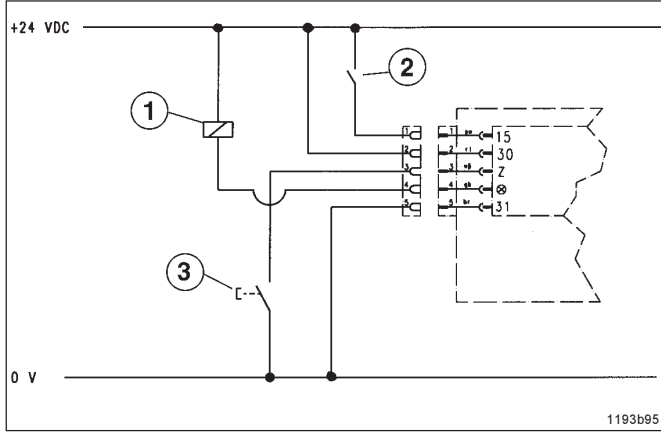

Fig. 1 - Supply voltage and machine contact

- 1 - external relay
- 2 - machine contact
- 3 - Push for additional lubrication

Possibilities of use

Lubrication cycles

- as a function of the machine operating hours and
- in addition, as a function of add-on units, auxiliary units, etc. which **temporarily** run during the machine operating hours and **must be lubricated only within their running time.**
- The power supply (+ and -) is applied (jumper 15/30, Fig. 3, has been removed). When the machine contact (external contact) is switched on, the centralized lubrication system is ready for operation.
- Indication of the time of availability: external relay 1 (Fig.1) has picked up, LED (Fig.11) is lit.

Advantages

- The central lubrication system is monitored, i.e. the readiness for service and faults are indicated (**industrial applications** : permanent signal, see LED fig.11).

Note: Applications for commercial vehicles and industrial applications with flashing fault signal : refer to "Technical Description" of printed circuit board 236-13870-1, models M 00 - M 15

- The following functions and operations are monitored and indicated as a fault in the case of a malfunction.

Pump:	System:
Function of the drive motor Supply voltage failure - no lubrication Pump element does not supply - no lubrication Reservoir empty (if low-level control not available) - no lubrication <i>Note: The fault is only indicated when the reservoir is completely empty and as soon as the pump element stops dispensing the lubricant.</i> Reservoir empty (when low-level control available) - The lubrication cycle occurs until the end of the operating time. <i>Note: The fault is indicated when the reservoir is empty, but if the pump element is still surrounded with lubricant.</i>	Lubrication point or metering device blocked Main line leaking (from pump to the monitored metering device) Air bubbles in the grease Lubrication circuit 1 and/or - if any- lubrication circuit 2 malfunctioning

*M 16 - M 23 is the designation of the respective version of the printed circuit board (see "Combinations of the jumper positions", page 15). It is part of the pump type designation code mentioned on the nameplate of each pump.

- The signal output via an external relay is given as follows:

Permanent signal (D)

Jumper B/D removed

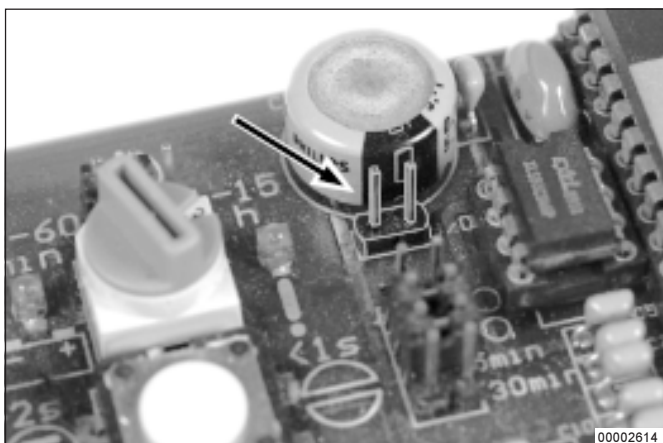

Fig. 2 - Printed circuit board without B/D jumper

System	External relay
Readiness for service O.K. (there is no fault)	Is picked up LED (Fig. 11) is lit permanently
Fault	Has dropped out, LED is not lit, the central lubrication pump does not start

Power Supply

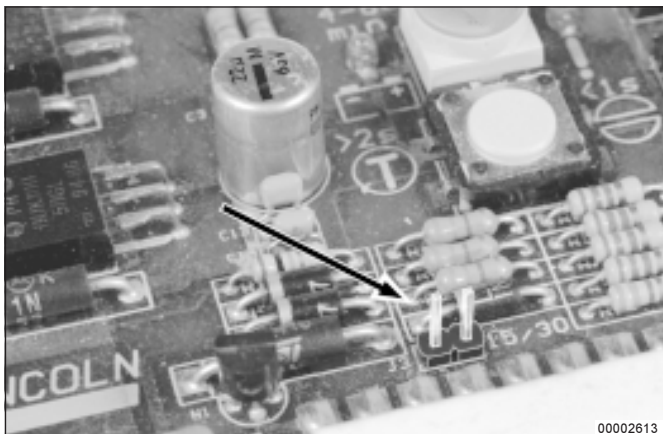

Fig. 3 - Printed circuit board without jumper 15/30

- The central lubrication pump must be connected to the supply voltage (+ and -).
- The machine contact (external contact) is used for the activation as a function of auxiliary units or drives, etc.. See Fig. 1.

Subject to change without notice

Mode of Operation

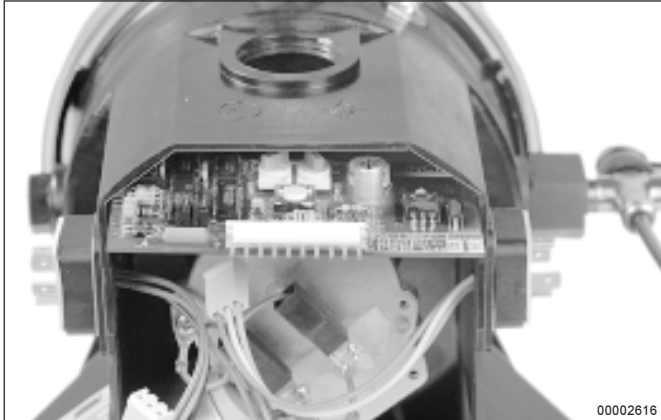

Fig. 4 - Printed circuit board installed in the housing

The printed circuit board

- is integrated in the pump housing.

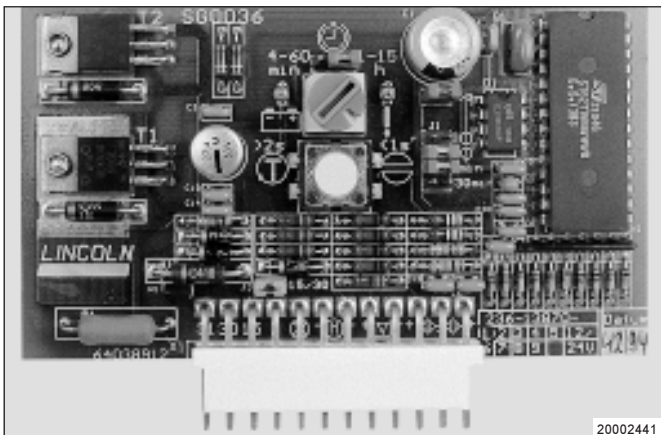

Fig. 5 - Printed circuit board 236-13870-1

- automatically controls the sequence of the pause and operating times of the 203 central lubrication pump as a function of the machine working hours t_B (Fig. 6) and as a function of the machine contact (external contact).
- The sequence of the pause and operating times is activated when the machine contact is switched on.

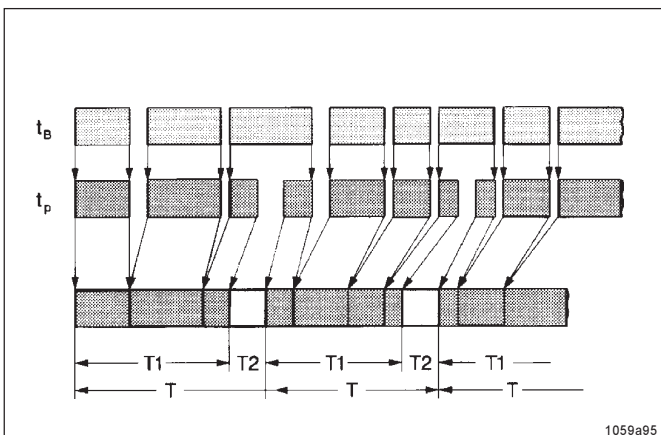

Fig. 6 - Time sequence diagram

- A lubrication cycle consists of one pause time and one operating time. Once the pause time has elapsed, the operating time starts to run. This lubrication cycle is repeated permanently after the machine has been put into operation. Refer to Fig. 6.
- During the operating time the pump element delivers the lubricant to the lubrication points via progressive metering devices.

t_B - Working hour
 t_P - Various pause time
 T - Lubrication cycle
 T_1 - Stored pause times
 T_2 - Operating times

Subject to change without notice

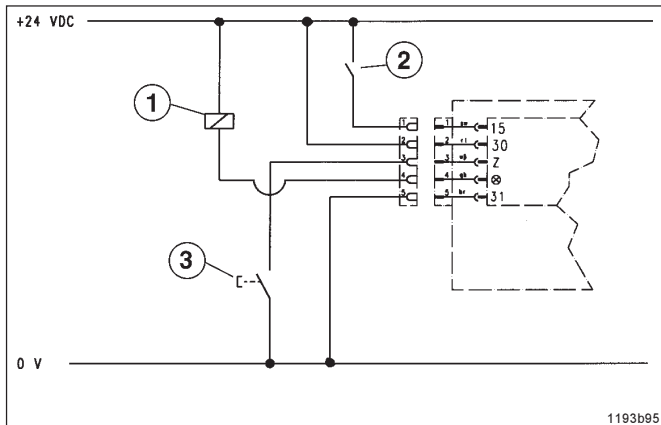

Fig. 7 - Connection diagram

- 1 - External relay
- 2 - Machine contact
- 3 - Pushbutton for additional lubrication

- Two seconds after the supply voltage has been applied the monitoring output (connection 4 of the 5-wire connector) is activated.
- A relay connected externally (see Fig. 7) picks up and signals the readiness for service of the 203 lubrication pump.
- The LED (Fig. 11) is lit.
- In the **case of a fault** (supply voltage failure, system malfunctioning) the relay drops out, thus providing a **fail-safe monitoring** of the central lubrication pump.
- The connected signal lamp is **not lit**.
- Switching on and off the machine contact (auxiliary units, auxiliary drives, etc.) has no influence on the function of the monitoring output.
- The drive motor continues to be monitored.

Output for fault signal/readiness for service

The output for the activation of the external relay (NPN transistor) is short-circuit proof and overload-proof. **The maximum current switched is 3 A.**

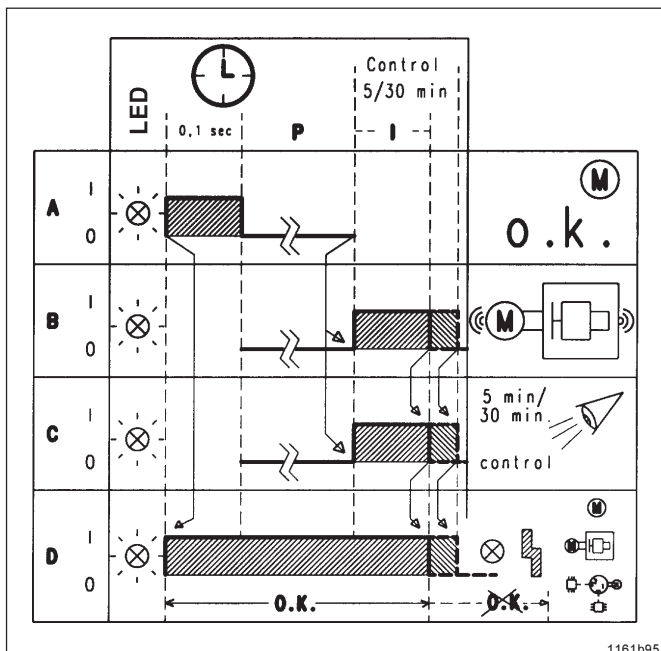

Fig. 8 - Sequence of a lubrication cycle

- A - Monitoring of the motor
- B - Sequence of the operating time
- C - Sequence of the monitoring time
- D - Readiness for service and fault indication
- I - Operating time
- P - Pause time

Pause time

- The pause time
 - determines the frequency of the lubrication cycles within a working cycle;
 - is started and stopped via the machine contact;
 - is adjustable.
- When the supply voltage is switched off, the pause times which have already elapsed as well as the momentary operating conditions (faults) are stored by an electronic memory (EEPROM).
- After the supply voltage is switched on again, the printed circuit board operates from the point where it had been interrupted.
- If the setting is modified within the pause time, the printed circuit board takes over the new value only at the end of the operating time.
- The pause time setting may be different for each application. It must be adjusted in accordance with the respective lubrication cycles. Also refer to "To set the pause time".

Subject to change without notice

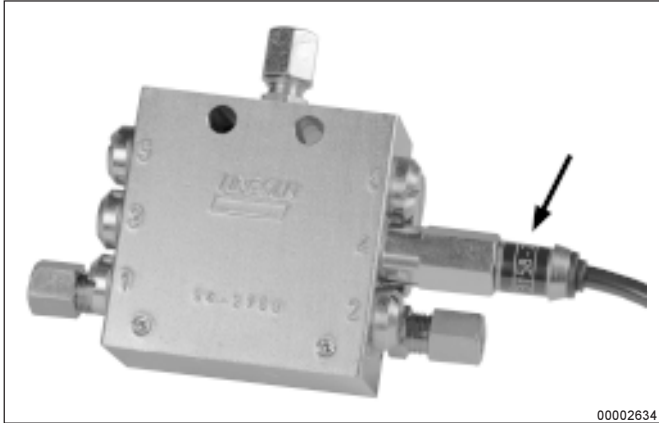

Fig. 9 - Piston detector installed on the metering device

Operating time

- A **piston detector** (initiator) which has been installed on a metering device instead of a piston closure plug monitors and brings the pump operating time to a close after all the pistons of this metering device have dispensed their lubricant quantity.
- The **operating time** depends on the system's lubricant requirement and the location of the piston detector (installed either on the main metering device or on the secondary metering device).
- *Note: If two lubrication cycles are monitored, the operating time ends after the two piston detectors have transmitted their signal to the printed circuit board.*
- The **operating time** always completely elapses, even if the machine contact is switched off.

Monitoring time

- A fixed **monitoring time** of max. 5 or 30 minutes (depending on the jumper position) runs in parallel to the operating time.

Note: Normally, the monitoring time ends at the same time as the operating time.

- If there is **no switching off signal** from the piston detector to the printed circuit board within 5 or 30 minutes, a **fault signal** will occur. The LED (Fig. 11) is extinguished and the pump stops operating.
- If the **operating time exceeds 5 minutes**, the monitoring time can be changed from 5 to 30 minutes by replugging the jumper.
- If there are **two monitored lubrication cycles**, the jumper must be plugged to (2 "O").

Functional check

- Each time the machine contact (external contact) is switched on, a functional check of the drive motor takes place automatically.
- During the functional check the motor is switched on for **0.1 second** (the stirring paddle slightly rotates).
- If there is a fault, the **LED is not lit** and the pump stops operating. See "Fault indication".

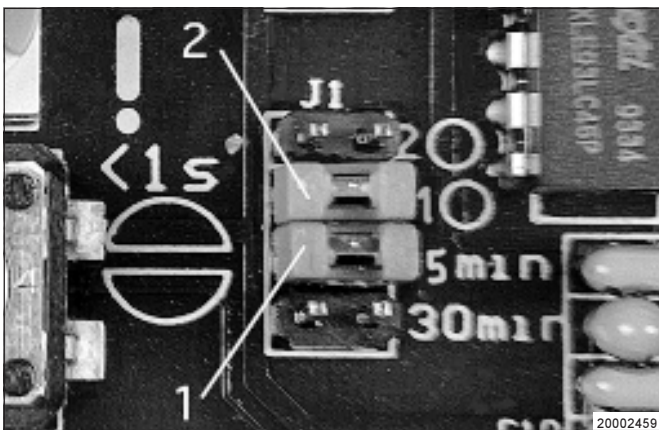

Fig. 10- Monitoring ranges

- 1 - Jumper for monitoring time
 - 5 min 5 minutes
 - 30 min 30 minutes
- 2 - Jumper for
 - 1 circuits 1 O
 - or 2 circuits 2 O

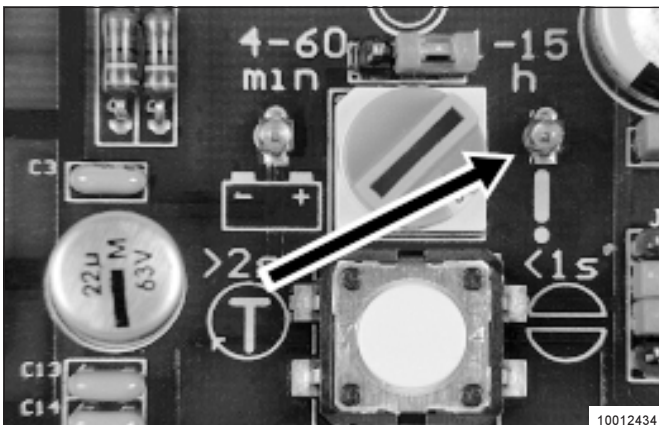

Fig. 11- LED display for the monitoring time or fault indication

Subject to change without notice

Functions of the Pushbutton and LED Display

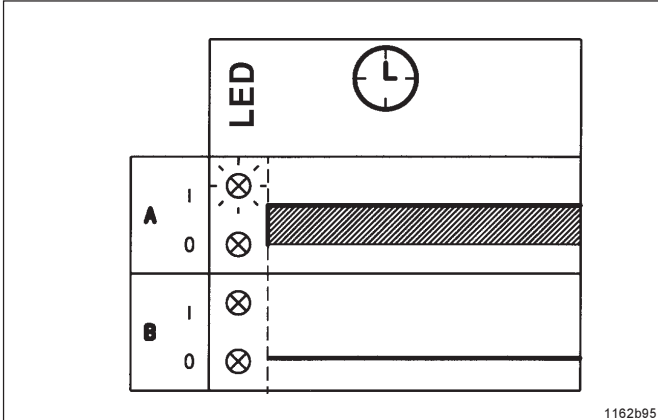

Fig. 12 - Indicated operating states

A - Indication of function
 B - Fault indication

Pushbutton

- The following can be performed with the pushbutton (item 4, Fig. 16):
- triggering an additional lubrication cycle - Press pushbutton for over 2 seconds (> 2 s)
- in the case of a fault, switch on pump again by pressing pushbutton (> 2 seconds)

LED display

- The LED display indicates the operating state of the centralized lubrication system.
- The operating states may be:
 - LED is lit permanently System o.k.
 - LED is not lit There is a fault

To Remedy to a Fault

- * In the case of a fault, check whether the central lubrication pump and the connected system are malfunctioning.
- * Eliminate the cause of the fault. Refer to "The faults and their causes".
- * Switch the pump on again by triggering an additional lubrication cycle. For this, press the pushbutton (4, Fig. 16) **>2 seconds**.
- Once the fault is eliminated, the LED will be lit again at the end of the lubrication cycle.

Important: If there has been any fault, the pump will not start automatically after the elimination of that fault. It must be switched on, i.e. an additional lubrication cycle must be triggered. See item "To trigger an additional lubrication cycle".

Time Setting



Fig. 13 - The cover to access the printed circuit board has been removed

* To set the pause time, remove the cover on the pump housing.

Note: To reset or remove a jumper, remove the printed circuit board.

Important: After having set the pause time, screw the cover on the pumphousing again.

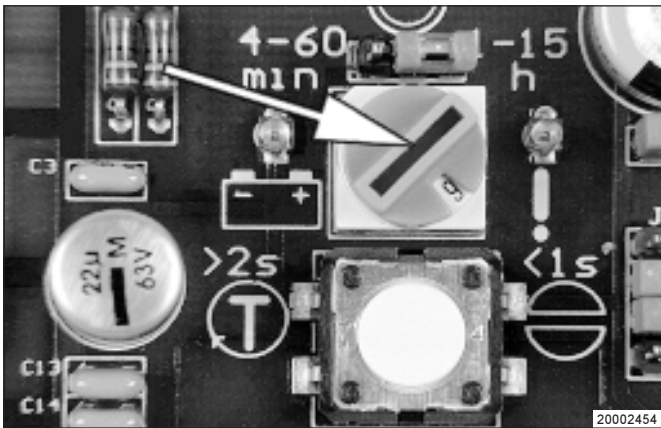

Fig. 14 - Rotary switch - Pause time

To set the pause time

The pause time can be adjusted to 15 different settings by means of the blue rotary switch.

Time ranges: Minutes or hours

Switch position	1	2	3	4	5	6	7	8	9	A	B	C	D	E	F
Minutes	4	8	12	16	20	24	28	32	36	40	44	48	52	56	60
Hours	1	2	3	4	5	6	7	8	9	10	11	12	13	14	15

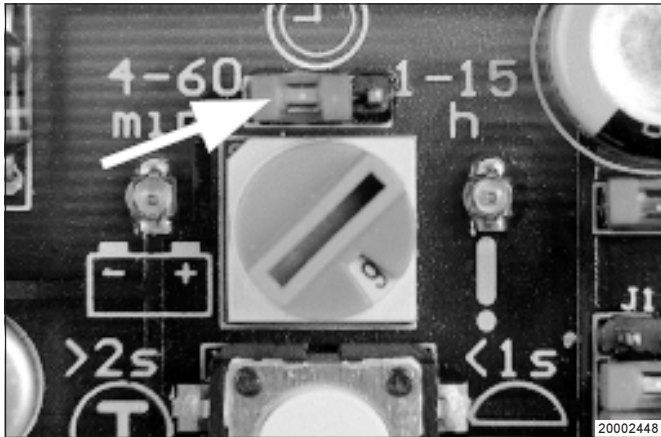

Fig. 15 - Preselection of the time ranges

Factory setting

Note: The 0 position corresponds to the shortest time.

- The time ranges (hours or minutes) can be changed by replugging the jumper on the printed circuit board (Fig. 15).

Pause time

Rotary switch on 6 hours
 or 24 minutes

- Refer to the chart page 15 for the jumper factory setting. The combination number can be learnt from the pump type designation code mentioned on the nameplate of each pump.

Operational Test /To Trigger an Additional Lubrication Cycle

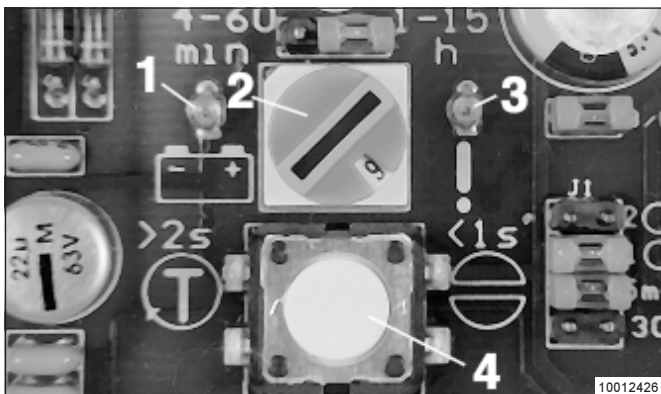

Fig. 16 - LED of the printed circuit board

- | | |
|------------------------------------|--|
| 1 - LED, left-hand
Power supply | 3 - LED, right-hand,
Indication of operation |
| 2 - Rotary switch
"pause time" | 4 - Pushbutton for
additional lubrication cycle |

- To check the function of the pump it is possible to perform an operational test.

- * Switch on the power supply
- * Switch on the machine contact
- To check whether power is applied to the printed circuit board, observe whether the left-hand LED 1, Fig. 16, is lit.
- Press the pushbutton (> 2 seconds) for triggering an additional lubrication (pushbutton on the printed circuit board or pushbutton on the switch cabinet) until the pump starts.
- A shorter pause time elapsed, followed by a normal lubrication cycle.
- The right-hand LED shows the following functions:
 - Operation (LED is lit)
 - Faults (LED extinguished)
- Additional lubrication cycles can be triggered at any time

Repair

- The defective printed circuit boards should be suitably packed and returned to the factory.
- If the printed circuit board must be replaced, a **model M 00** will always be **delivered**. See chart page 15.
- Before installing another printed circuit board, take care that the jumper is set to the same position as on the old printed circuit board.

Subject to change without notice

The Faults and their Causes

Fault Indication

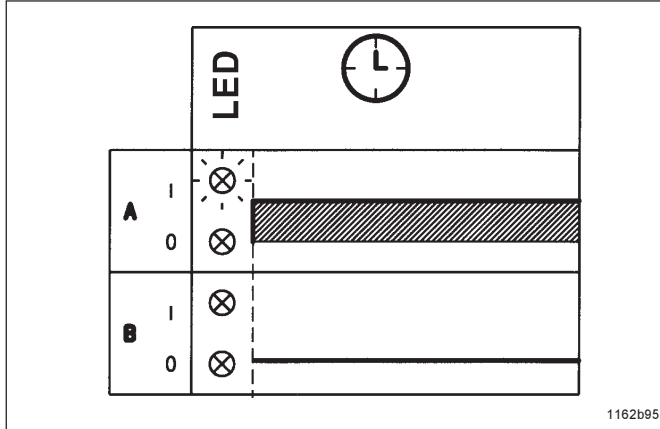

Fig. 17 - Readiness for service and fault indication

A - Readiness for service
 B - Fault indication

- If any the following faults occurs, the LED is extinguished, the external relay drops out and the pump stops operating.

Faults

- Drive motor defective
 - The external relay drops out, the LED is extinguished after 2 seconds
- Malfunctions such as
 - blocked lubrication point (s)
 - blocked metering devices (s)
 - interruption in the main line leading to the metering device equipped with a piston detector
 - air in system
 - reservoir empty
 - are not indicated as individual faults.
- In the case of a malfunction the piston detector (initiator) can no longer record the piston movements and, therefore, it cannot switch off the pump.
- Due to the monitoring time which runs in parallel to the operating time, the printed circuit board switches off the pump at the end of the monitoring time
- **The external relay drops out, the LED is extinguished.**
- The pump no longer starts automatically. See "To Remedy to a Fault".
- Reservoir empty in the case the pump is equipped with a low-level control.
 - The LED is extinguished. The operating time comes to a close.
 - The pump no longer starts automatically. See "To Remedy to a Fault".

Troubleshooting

Note: The pump operation can be checked from the outside by observing whether the stirring paddle is rotating (e.g. by triggering an additional lubrication), whether the LED on the printed circuit board are lit or whether the external relay has picked up.

• Fault: The pump motor does not run	
• Cause:	• Remedy:
<ul style="list-style-type: none"> • Voltage supply interrupted • Voltage supply to the printed-circuit interrupted • Printed circuit board defective 	<ul style="list-style-type: none"> • Check the voltage supply to the pump. If necessary, correct the cause of the fault. • Check the line leading from the pump plug to the printed circuit board. • If the voltage is applied, the left-hand LED is lit. • Replace the printed circuit board.
• Fault: The pump motor supplies permanently (5 minutes or 30 minutes)- Duration of the monitoring time	
• Cause:	• Remedy:
<ul style="list-style-type: none"> • Piston detector (initiator) defective. • Cable connection of the piston detector to the pump interrupted • Printed circuit board defective 	<ul style="list-style-type: none"> • Disconnect the main line leading to the monitored metering device. • Unscrew the piston detector and check it. For this, insert a metallic pin into the borehole of the detector. Let it there over 2 seconds and then remove it. If the pump is not switched off afterwards, check the cable connections to the pump. If necessary, replace the piston detector with the connector. • Check the cable connections to the pump. If necessary, replace the piston detector with the connector. • Replace the printed circuit board

Technical Data

Rated voltage 12/24V DC
 Operating voltage
 12V/ 24V 9V to 30V
 Residual ripple in relation
 with the operating voltage ± 5% acc. to DIN 41755
 Motor output transistor 7A/short-circuit proof
 Reverse voltage protection:
 The operating voltage inputs are protected against
 polarity reversal
 Temperature range: -25°C to 70°C
 Output fault/readiness for operation
 transistor 3A/short-circuit proof
 Protection
 Printed circuit board installed in housing IP 6K 9K

In order to protect the printed circuit board against condensation, it is covered with a protective varnish.

The printed circuit boards model **M** comply with the EMC guideline 89 / 336 / EWG
 Emitted interference acc. to EN 55011 / 03.91 and
 EN 50081-1 / 01.92
 Noise immunity acc. to prEN 50082-2 / 1993

Time Setting
 Pause time, acc.to jumper position:
 4, 8, 12,...to 60 minutes
 1, 2, 3...to 15 hours
 The operating time is switched off via the piston detector.

Factory setting
 Pause time 6 hours
 or 24 minutes
 Monitoring time 5 minutes
 or 30 minutes

Subject to change without notice

Connection Diagram

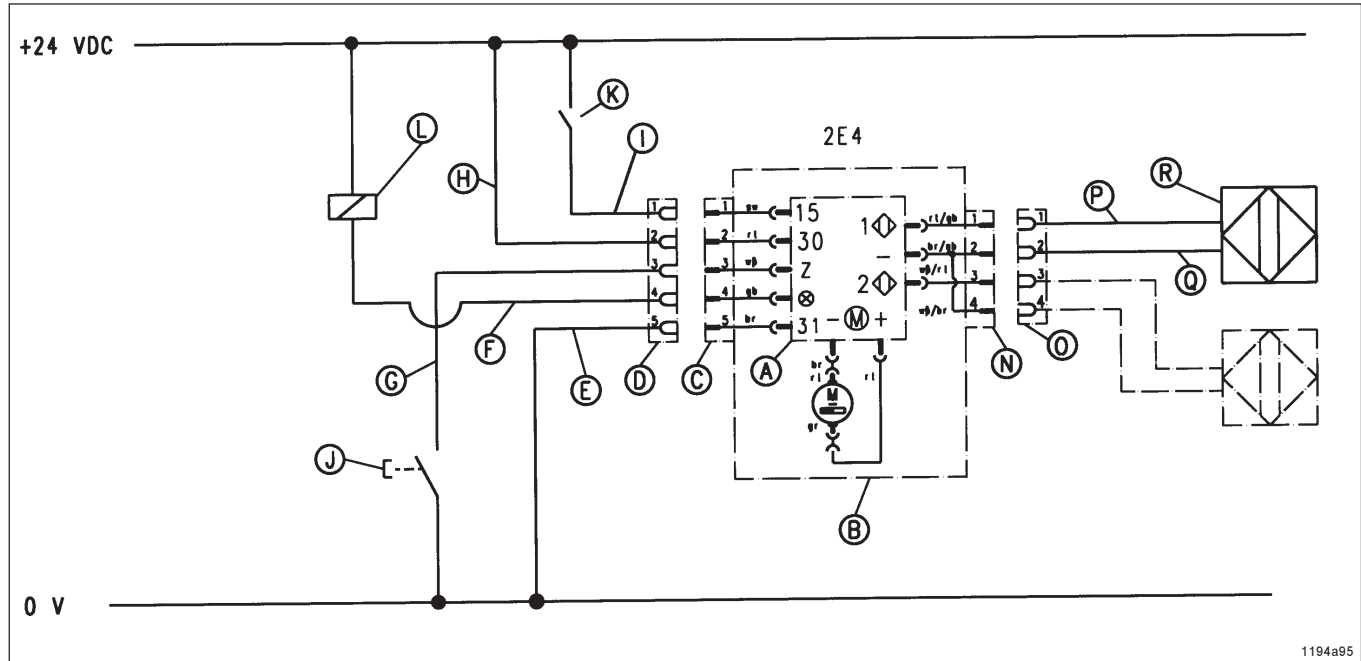

Fig. 18 - Connection diagram QUICKLUB 203 with monitoring of the metering devices (Industry)
 Connectors AMP, type Superseal

1194a95

- A - Printed circuit board
- B - Pump housing
- C - Cable connector 1
- D - Line socket 1 with connection cable, 5-wire
- E - Cable, brown
- F - Cable, yellow

- G - Cable, white
- H - Cable, red
- I - Cable, black
- J - Pushbutton for additional lubrication
- K - Machine contact
- L - Relay

- N - Cable connector 2
- O - Line socket 2 with 1 or 2 connection cables 2-wire
- P - Cable, blue
- Q - Cable, brown
- R - Piston detector (initiator) Monitored circuit 1

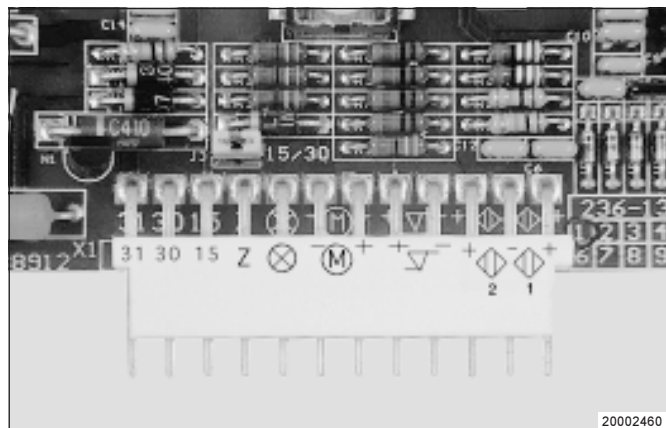

- 30 - Battery voltage
- 31 - Earth
- 15 - Machine contact
- (M) - Motor
- (◊) - Lubrication circuit 1
- (◊) - Low-level control
- Z - Additional lubrication
- (⊗) - Signal lamp
- (◊) - Lubrication circuit 2

Fig. 19 - Terminals of the printed circuit board

Subject to change without notice

Combinations of the jumper positions - Survey

Possibilities of preselection	Connection of the supply voltage		Signal indication in the case of faults Signal output		Pause time ranges		Monitoring time ranges (min)		Number of the monitored lubrication circuits	
	only terminal 15	terminal 15;30	intermittent	permanent	h	min	5	30	1	2
Jumper position	30 / 15	30 / 15	B / D	B / D	1 - 15 h	4 - 60 min	5 min	30 min	○ 1	○ 2
Kombination Nr.										
M 00	X		X		X		X		X	
M 01	X		X		X			X	X	
M 02	X		X		X		X			X
M 03	X		X		X			X		X
M 04	X		X			X	X		X	
M 05	X		X			X		X	X	
M 06	X		X			X	X			X
M 07	X		X			X		X		X
M 08		X	X		X		X		X	
M 09		X	X		X			X	X	
M 10		X	X		X		X			X
M 11		X	X		X			X		X
M 12		X	X			X	X		X	
M 13		X	X			X		X	X	
M 14		X	X			X	X			X
M 15		X	X			X		X		X
M 16		X		X	X		X		X	
M 17		X		X	X			X	X	
M 18		X		X	X		X			X
M 19		X		X	X			X		X
M 20		X		X		X	X		X	
M 21		X		X		X		X	X	
M 22		X		X		X	X			X
M 23		X		X		X		X		X

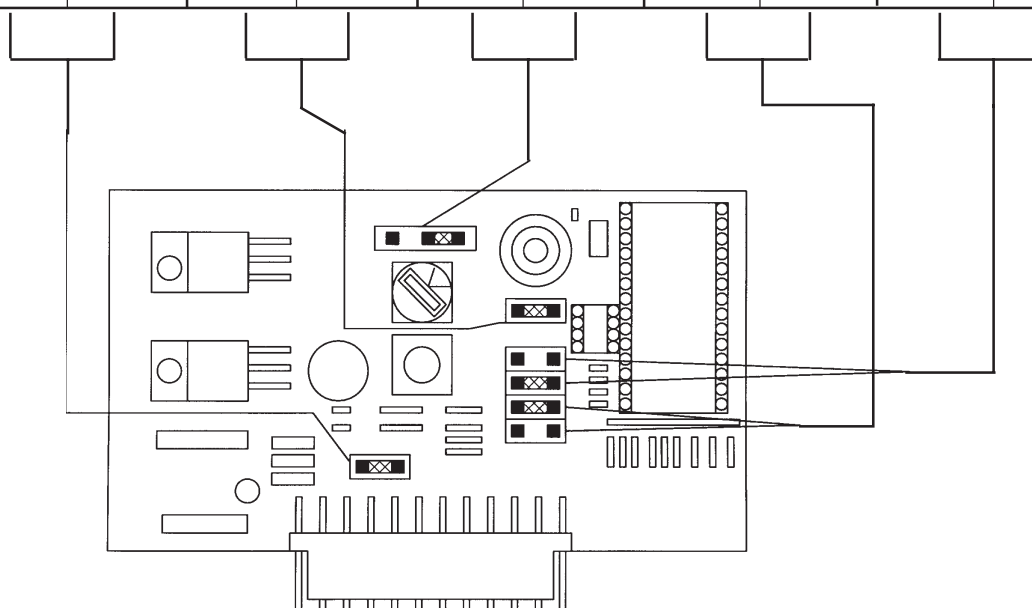

Subject to change without notice