

Quicklub[®]

Pump model 203 with power supply board for 94 - 265 VAC

with and without printed circuit board V 10 - V 13

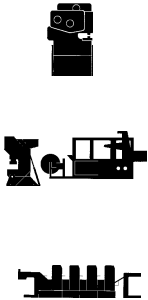

Fields of Applications of the QUICKLUB Progressive Central Lubrication Pumps

Industry - Maschines	Pump Type
	<p>Pump : QUICKLUB 203</p> <p>Reservoir: 2 l - 2XN** 2XNFL**, 2YN***, 2XNBO*, 2YNBO*** 4 l - 4XNBO*, 4YNBO***, 8 l - 8XNBO*, 8YNBO*** * Filling from the top or bottom ** Filling only from the bottom ***Filling only from the top</p> <p>Low-level control for all reservoir sizes available on request</p> <p>Control: Without control unit Integrated control units (V10-V13)¹</p>

¹ See the respective model designation on the pump nameplate e.g. P203 - 2XN - 1K6 - 24 - 1A1.10 - V10

Table of Contents

	Page		Page
Fields of applications of QUICKLUB			
progressive central lubrication pumps	2	Control p. c. b. V10-V 13	14
Safety instructions	4	Mode of operation	14
Pump types	5	The pause time	15
Identification Code - Pump Models 203	6	The operating time	15
Description of the QUICKLUB 203		Time setting	16
Central Lubrication Pump	7	Maintenance, repair and tests	19
Mode of operation	8	Maintenance	19
Pump elements with fixed Lubricant output	8	Pump filling	19
Suction phase	8	Repair	19
Delivery phase	8	Tests	19
Check valve	9	Operational test/To trigger an additional	
Arrangement of the pump elements	9	lubrication	20
Pump element with adjustable lubricant output	9	To check the safety valve	20
Setting of adjustable pump elements	10	Troubleshooting	21
Retrofit adjustment of max. lubricant output	10	Technical data	22
Adjusting of small lubricant output	10	Torques	23
Pressure Relief Valve	11	Weights	23
Return Line Connection	11	Electrical Connection diagrams	24
Low-Level Control (optional)	12	Dimensions	26
Pump for grease	12	Lubricants	32
Pump for oil	13		
Contact protection measures	13		

Further information can be found in the following manuals:

- Technical Description for "Electronic Control Units" of the pump model 203
- Technical Description Progressive Metering Devices for Grease and Oil, model SSV
- Printed Circuit Board 236-13856-1 - Model F
- Printed Circuit Board 236-13862-1 - Model V10-V13
- Printed Circuit Board 236-13857-1 - Model H
- Printed Circuit Board 236-13870-1 - Model M 00 - M 15
- Printed Circuit Board 236-13870-1 - Models M 16 - M 23
- Control unit 236-13860-2 Model PSG02
- Installation Instructions
- Parts Catalog

Safety instructions

Appropriate Use

- Use the 203 pump only for dispensing lubricants in centralized lubrication systems. The pump is designed for intermittent operation.

General Safety Instructions

- LINCOLN - QUICKLUB - centralized lubrication systems
- are state of the art;
- can be assembled for safe operation.
- Incorrect use may result in bearing damage caused by poor or over-lubrication.
- Unauthorized modifications or changes to an installed system are not admissible. Any modification must be subject to prior consultation with the manufacturer of the lubrication system.

Regulations for Prevention of Accidents

- Adhere to the regulations for prevention of accidents which are effective in the country where the system is to be used.

Operation, Maintenance and Repair

- Repair should only be performed by authorized and instructed personnel who are familiar with the regulations.
- LINCOLN QUICKLUB central lubrication pumps must only be operated with a fitted safety valve.
- LINCOLN QUICKLUB central lubrication pumps must be regularly refilled with clean lubricant.

Attention: In the case of pumps which are filled from the reservoir cover, switch off the power supply before filling in the lubricant.



Attention: When filling the reservoir by means of pumps with a large delivery volume do not exceed the max. filling mark. Risk of bursting if the reservoir is overfilled.

- LINCOLN QUICKLUB centralized lubrication systems operate automatically. However, a regular check (about every two weeks) should be made to ensure that lubricant is actually reaching all the lubrication points.
- Defective printed circuit boards shall be suitably packed and returned to the factory.
- Dispose of used or contaminated lubricants in accordance with the legislation concerning the environment.
- The manufacturer of the centralized lubrication system will not accept any liability
- for damages due to the use of greases which are not or only conditionally pumpable in centralized lubrication systems
- for damage caused by insufficient lubricant and irregular pump refilling;
- for damage caused by the use of contaminated lubricants
- for damage caused by an environmentally incompatible disposal of used or contaminated lubricants.

Installation

- Any safety equipment already fitted to the vehicle or the machine:
 - should not be modified or made ineffective;
 - should only be removed for the purpose of fitting the system;
 - must be replaced afterwards.
- Keep QUICKLUB centralized lubrication systems away from sources of heat. Adhere to the operating temperature.
- Use only original LINCOLN spare parts (see Parts Catalog) or parts approved by LINCOLN.
- Adhere to:
 - the installation instructions of the vehicle or machine manufacturer as regards all drilling and welding procedures.
 - the specified minimum distances between the bore holes and the upper/lower rim of the frame or between two bore holes.
- The manufacturer of the centralized lubrication system will not accept any liability for:
 - damage caused by unauthorized modification of the system components;
 - damage caused by the use of unapproved spare parts.

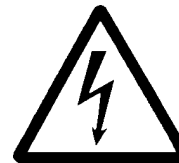
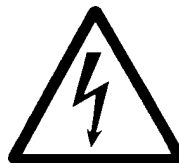

- The pump 203 may only be installed by qualified personnel. The connection (N/L/PE) of the supply voltage must be made according to VDE 0100 and VDE 0160.
- Install a protective and lock out device for isolating and disconnecting the pump 203. Before beginning the installation work, disconnect the electrical supply .
- Failure to observe the safety instructions, e. g. touching electrically charged parts when the system is opened, or improper handling of the pump 203 may **cause serious injury or death**.
- If the values specified in the Technical Data are exceeded, the device may overheat. It may damage the pump 203 and thus impair the electric safety.

Pump Types



Fig. 1: - Variants of pump model 203

1173a95

- **The 203 pumps** differ from each other only in the design and reservoir size as well as in the type of the electric connection. It is not possible to trigger an external additional lubrication cycle as well as the connection of an external control lamp.
- **Reservoir sizes:**
 - 2 l transparent plastic reservoir
 - 4 l transparent plastic reservoir
 - 8 l transparent plastic reservoir
- **Electric connection**
For the **industrial applications**, the pumps are only equipped with plugs.
- All other data such as:
 - operating voltage
 - version of the control unit
 - remote control for triggering an additional lubrication cycle (2A1)
 - design and number of pump elements
 - design and number of safety valves
 - filling type
 - use of return line connections
 - low - level control (option)can be learnt from the pump type designation code.

- **Control unit models 203**

The following control units can be used for the 203 pumps: (refer to the respective Technical Description)

- a) without integrated control units
- b) with integrated control units V 10 - V 13*

* Refer to the designation on the pump nameplate.
Example: P203 - 4XNBO - 1 K6 - AC - 1A1.01 - **V10**
Also refer to the designation code on page 6.

Identification Code - Pump Models 203

Examples of model designation

P203- 2 X N - 1 K6 - AC 1A 1. 01 - V10
 P203- 4 X L - 1 K7 - AC- 2A 1. 01

Basic pump model for grease or oil with 1-3 outlets and 24 VDC motor

Reservoir design

2 - 2 l transparent plastic reservoir
 4 - 4 l transparent plastic reservoir
 8 - 8 l transparent plastic reservoir

X = Reservoir for grease
 Y = Reservoir for Oil

N = Standard designation
 L = Low level control

Without designation=Standard reservoir (2 litres)
 BO = Filling from top
 FL = Flat type reservoir (2 litres)

Pumpelements

1-3 = Number of the used elements

K 5 = piston elements = 5mm
 K 6 = piston elements = 6mm
 K 7 = piston elements = 7mm
 KR = Pump element , adjustable

Power Supply

AC = 94 - 265 VAC (47-63Hz) with 24 VDC motor

Number of the possible connections

1A = 1 connection, supply voltage (left hand)
 2A1 = 1A1 + low level control (right hand)*, as potential free contact

Type Of Connection

1 = square type plug acc to din 43650 type of construction A

Connection outside of the pump

01 = with socket-outlet, without cable

Control P.C.P 24 V

V10-V13 = with adjustable pause and operation time

No designation : Pump without control P.C.B

Subject to change without notice

Note: Any pumps combination other the above standard pumps can be composed and used in accordance with the valid model indication code

Description of the QUICKLUB 203 Central Lubrication Pump

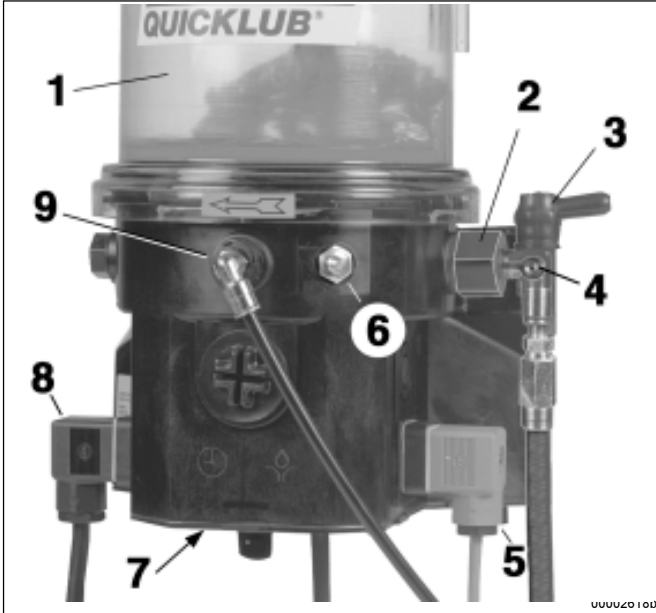

Fig. 2 - Pump components

- | | |
|----------------------------|-------------------------------------|
| 1 - Reservoir | 5 - Plug 2A1 |
| 2 - Pump element | 6 - Filling nipple, pump |
| 3 - Safety valve | 7 - Printed circuit board |
| 4 - Filling nipple, system | 8 - Plug 1A1 |
| Emergency lubrication | 9 - Return line connection possible |

• The QUICKLUB 203 central lubrication pump

- is a compact multiline pump consisting of the following components:

- Housing with integrated motor
- Reservoir with stirring paddle
- Printed circuit board
- Power supply board
- Pump element
- Safety valve
- Filling nipple
- Power supply board

- can drive up to 3 pump elements
- operates according to lubrication cycles (pause and operating times)
- can be equipped with a low-level control
- can supply up to 300 lubrication points depending on the line lengths
- is designed for the automatic lubrication of the connected lubrication points
- is designed for the delivery of greases up to NLGI 2 at temperatures from - 25° C to 70° C or of mineral oils of at least 40 mm²/s (cST)
- can be used at low temperatures down to - 40° C.
- During the operating time the pump dispenses lubricant to the connected lubrication points via one or several metering devices.



Fig. 3 - QUICKLUB central lubrication pump, 2 l reservoir

Low-level control (optional)

- The **pump model 203** can be equipped with a low-level control.
- The following versions are available:
 - Low-level control in conjunction with printed circuit boards **V 10 - V 13***
 - Low-level control for pumps **without printed circuit board**.
- When the reservoir is empty, the signal lamp flashes, thus indicating the low level. Refer to the chapter Low-level control.

* The designation indicates the version of the printed circuit board. It is part of the pump type designation code mentioned on the nameplate of each pump. Example: P203 - 2XL - 1K6 - AC - 1A1.01 - V10

Subject to change without notice

Mode of Operation

Pump Elements with fixed Lubricant output

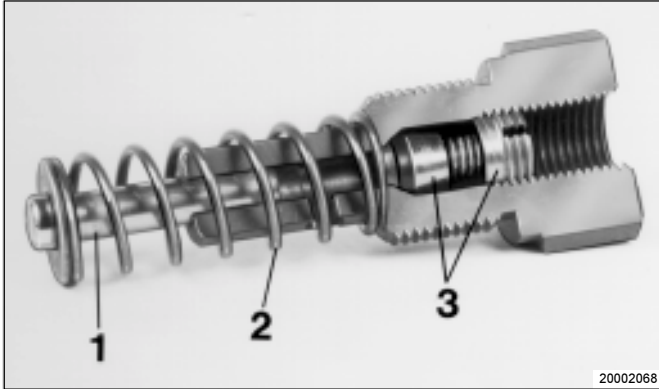

Fig. 4 - Pump element

- 1 - Piston
- 2 - Return spring
- 3 - Check valve

- The electric motor drives the eccentric 1 (Fig. 5, 6).
- During the operating time:
 - piston 2 sucks in lubricant from the reservoir. Refer to Fig. 5.
 - piston 2 dispenses the lubricant to the connected lubrication points via the metering device. Refer to Fig. 6.

- The following designs are available:

Piston diameter, K5	5 mm
Lubricant output	approx. 2 cm ³ /min
Piston diameter K6 (standard)	6 mm
Lubricant output	approx. 2.8 cm ³ /min
Piston diameter, C7, K7	7 mm
Lubricant output	approx. 4 cm ³ /min

Note: Pump elements with piston diameter C 7 must be used for supplying of chisel paste. The design and the mode of operation are the same as those of the pump elements with piston diameter K 7.

Suction Phase

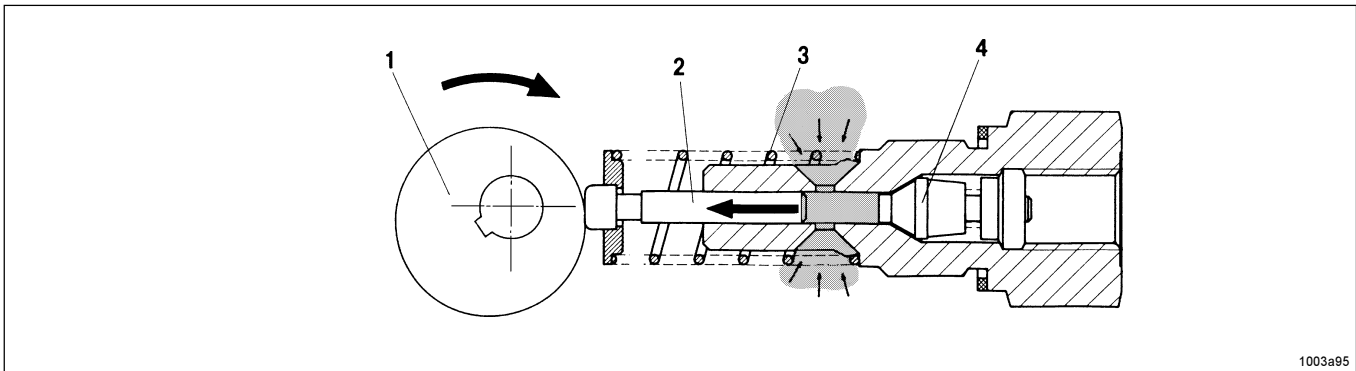

Fig. 5 - The pump element sucks in lubricant

- 1 - Eccentric
- 2 - Piston
- 3 - Spring
- 4 - Check valve

Delivery Phase

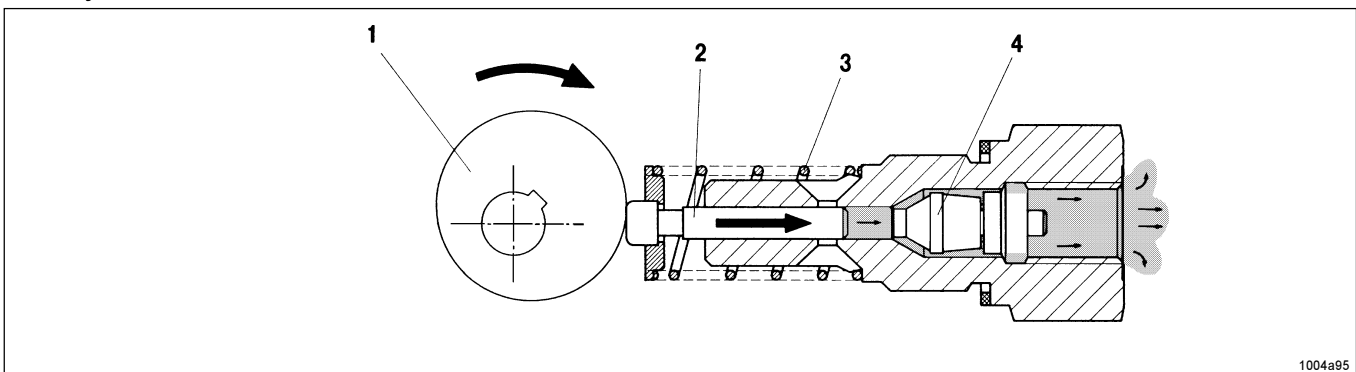

Fig. 6 - The pump element dispenses lubricant

- 1 - Eccentric
- 2 - Piston
- 3 - Spring
- 4 - Check valve

Check valve

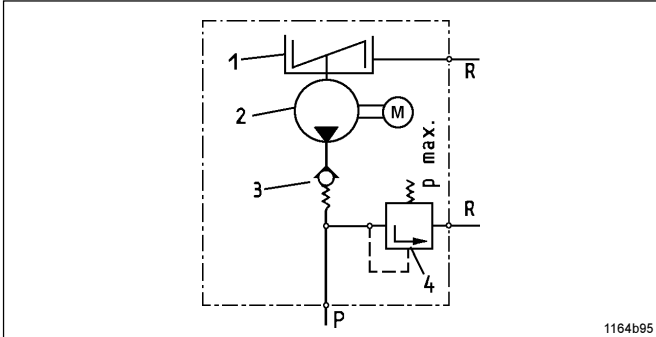

Fig. 7 - Hydraulic diagram of the pump

- The check valve 3, fig. 7 or 4 fig.5 and 6:
 - closes the pressure line during suctionstroke
 - prevents the lubricant from flowing back to the housing or reservoir

- 1 - Reservoir with stirring paddle
- 2 - Pump
- 3 - Check valve, spring-loaded
- 4 - Pressure limiting valve
- R - Return line
- P - Pressure line

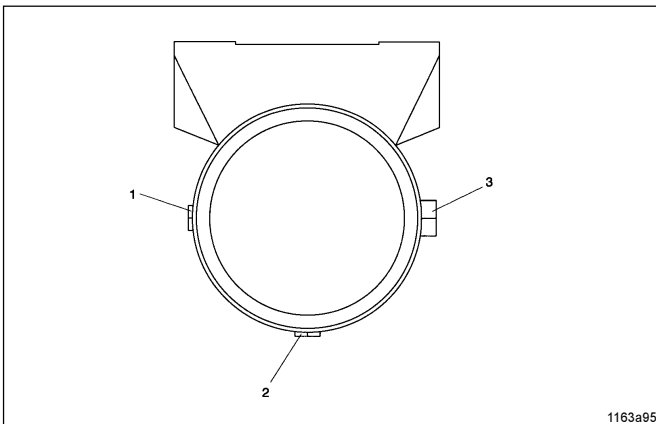

Fig. 8 - Arrangement of the pump element

Arrangement of the pump elements

- If several pump elements are to be installed, the installation arrangement shown in Fig. 9 must be adhered to.
- If there is only **one** pump element, it can be installed in **any** position. Standard position is no. 3.
- If there are two elements, install one in position 3 and the other in position 1.

Pump Element with adjustable Lubricant output



Fig 9 - Adjustable Pump element

- The mode of operation (suction and supply phase) is the same as that of the pump elements with an invariable lubricant output.
- The lubricant outputs are adjustable from 0.04 to 0.18cm³/stroke, or 0.7 to 3 cm³/min.
- The pump elements are factory-adjusted to the maximum lubricant output; the adjusting dimensions „S“ should be 29 ± 0.1 mm.

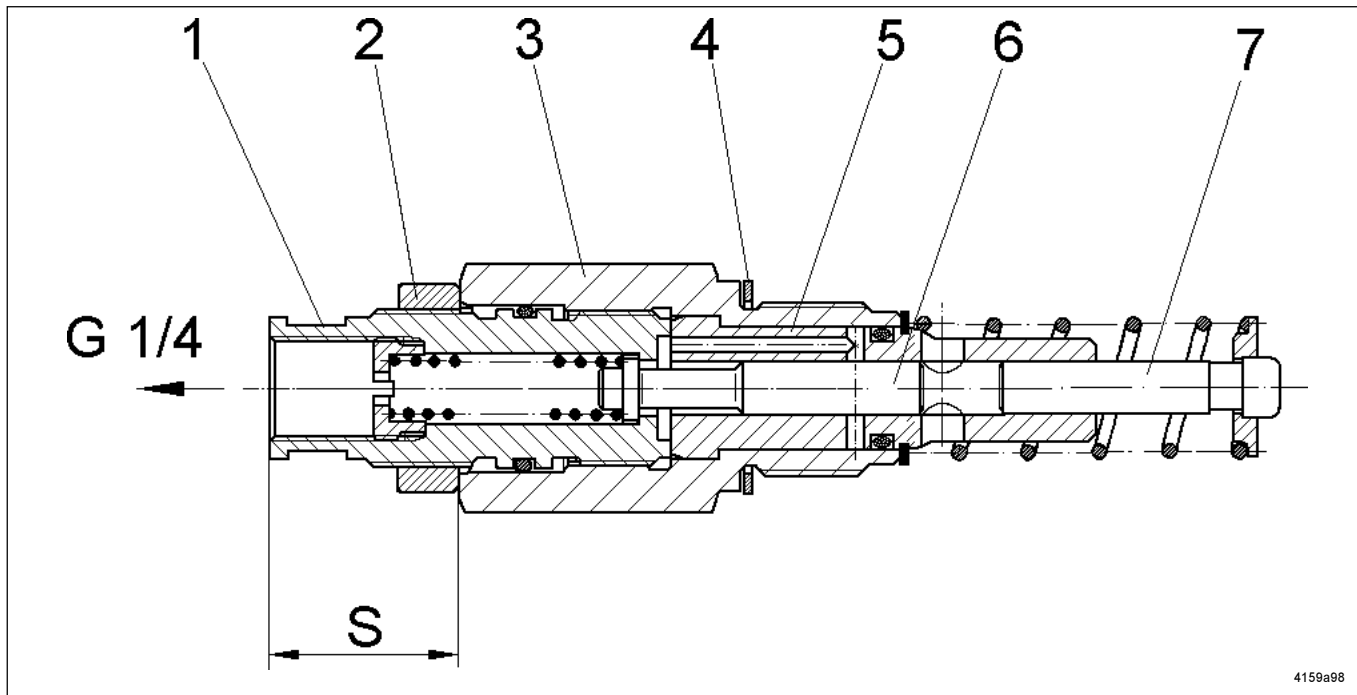

Fig. 10 - Sectional view: adjustable element

- | | | |
|--|-----------------------|---------------------|
| 1 - adjusting spindle SW 16
(with over flats) | 3 - pump element body | 6 - control piston |
| 2 - counter nut SW 24 | 4 - gasket | 7 - delivery piston |
| | 5 - pump cylinder | S - dimension |

Setting of adjustable pump elements

- Unscrew the coupling nut for fixing the safety valve
- Loosen counter nut (2, Fig. 10) while holding in position pump element body (3) by means of a second wrench.
- Change the position of the adjusting spindle (1) by means of a wrench.

turning clockwise = decreasing piston
turning counterclockwise = increasing piston

- The dimension „S“ (see Fig. 10) for the desired lubricant output can be ascertained by using the delivery diagram shown in Fig. 11.
- The pump elements are factory set to maximum lubricant output.

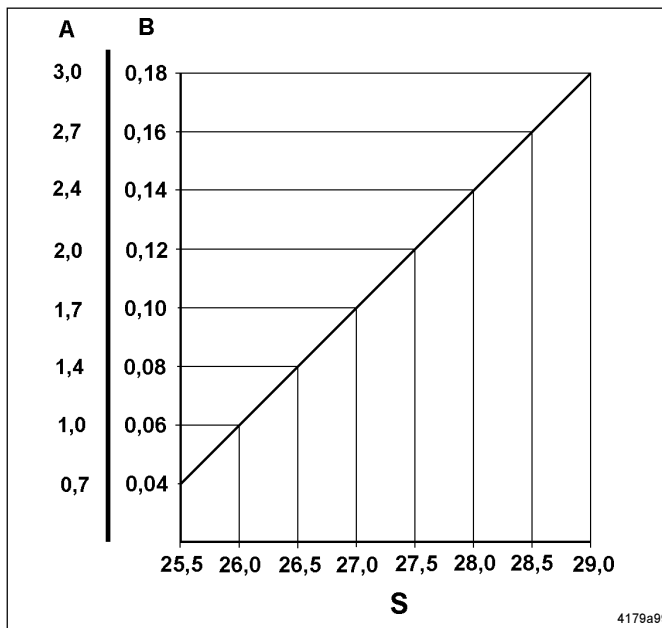

Fig. 11- Diagram for lubricant output
A = Lubricant output cm³/min B = Lubricant output cm³/stroke
S = Dimensions

Retrofit adjustment of maximum lubricant output:

Note: In order to ensure that the lubricant output setting will be as exact as possible, first the actual dimensions „S“ of the max. lubricant output must be ascertained as follows. The measured difference from the nominal value 29 must be considered for all other settings values (e.g. ± 0.1).

- Unscrew the adjusting spindle (1, Fig 10) from the pump element body (3) until „S“ is approx. 30 mm.
- Screw counter nut (2) onto stop collar of the adjusting spindle (1)
- Screw adjusting spindle (1) with counter nut (2) into pump element body (3) until stop.

Adjusting of small lubricant output:

- Before the pump element can be adjusted to small lubricant output, the dimension „S“ for max lubricant output must be ascertained, and the difference from the nominal value 29 must be transferred to any desired settings between 25.5 ... 28.5.

- Dimension „S“ must be adjusted to the desired value in accordance with the delivery diagramm (Fig. 11).

Note: At maximum steering „S“ is 29 ±0.1 mm.

Pressure Relief Valve

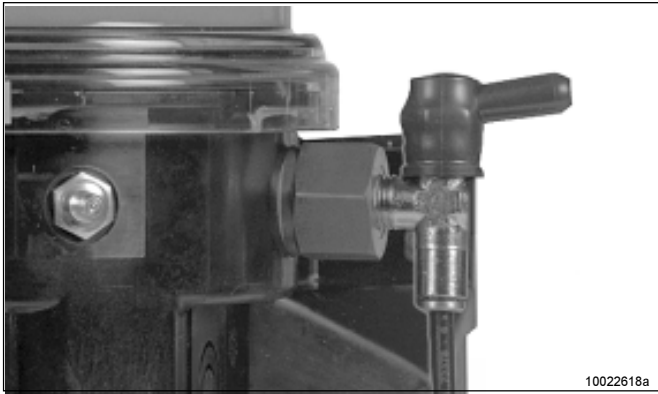

Fig. 12 - Pressure limiting valve

10022618a

Pressure relief valve without grease return

Important! Each pump element must be secured with a pressure relief valve.

- The pressure relief valve
 - limits the pressure build-up in the system
 - opens at an overpressure of 250 or 350 bar depending on the pressure relief valve design.
- If lubricant is leaking at the pressure relief valve, this indicates that the system is malfunctioning.

Note: The pumps model 203 are equipped without pressure relief valve. When ordering the pump, order the pressure relief valve separately. See the Parts Catalog under Pressure relief valves.



Fig. 13 - Pressure limiting valve with grease return

00002626a

Pressure relief valve with grease return (optional)

If the system is blocked, grease will leak from the pressure relief valve. This grease quantity is returned to the reservoir.

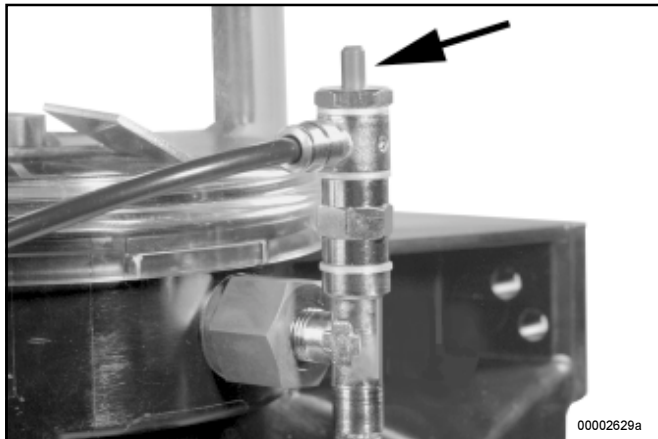

Fig. 14 - Fault indication in the case of a blockage

00002629a

In the case of a blockage in the system, the grease pushes out the red pin at the pressure relief valve, thus indicating that there is a fault.

Return Line Connection

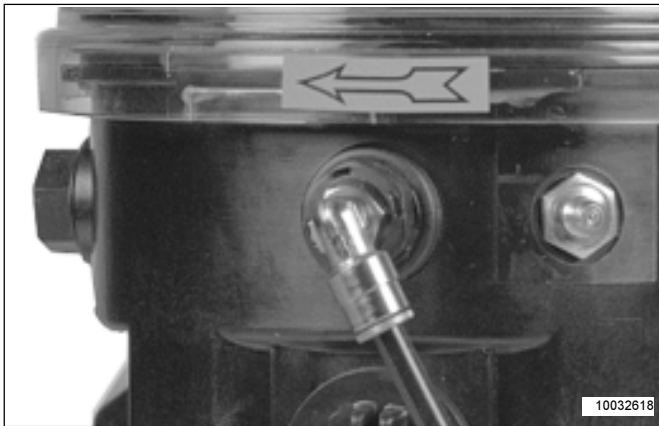

Fig. 15 - Return line connection

The lubricant quantities which cannot be dispensed by the metering device must be returned to the pump via the return line connection (Fig. 15).

Low-Level Control (optional)

Pump for Grease

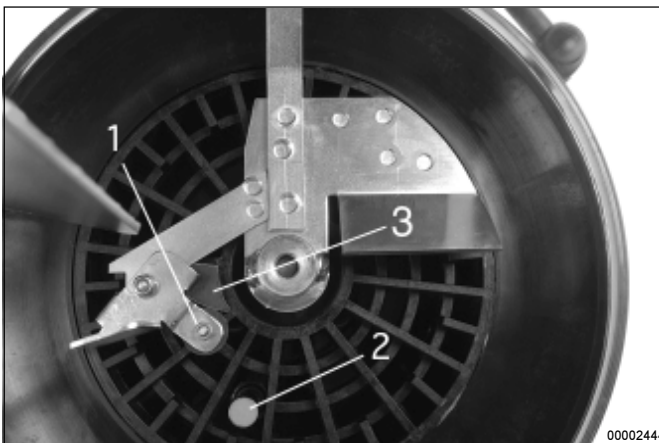

Fig. 16 - Switching parts of the low-level control

- 1 - Guiding plate with round solenoid
- 2 - Electromagnetic switch (at stirring paddle)
- 3 - Control cam

When the reservoir is filled

- The stirring paddle rotates **clockwise** during the operating time.
- Due to the rotating motion of the stirring paddle in the lubricant the pivoting guiding plate with the round solenoid, item 1 Fig.16, is pressed backwards. The solenoid moves toward the center of rotation of the stirring paddle. The electromagnetic switch item 2 **cannot** be activated.
- Control cam item 3 guides the round solenoid with the pivoting guiding plate automatically outwards, in the direction of the reservoir wall. After the lubricant has left the control cam, it flows against the guiding plate, thus displacing the solenoid again onto the center of rotation of the stirring paddle.

When the reservoir is empty

- During the rotating motion of the stirring paddle there is no backpressure from the lubricant. The guiding plate with the round solenoid no longer moves towards the center of rotation of the stirring paddle. After control cam 3 has been overtravelled, the solenoid remains in the outer position and overruns electromagnetic switch 2. The solenoid activates the electromagnetic switch contact-free, thus triggering a low-level signal.
- The flashing frequency in the case of printed circuit board 236-13862-1 (**V00-V03**) and in the case of pumps without control units depends on the motor speed.

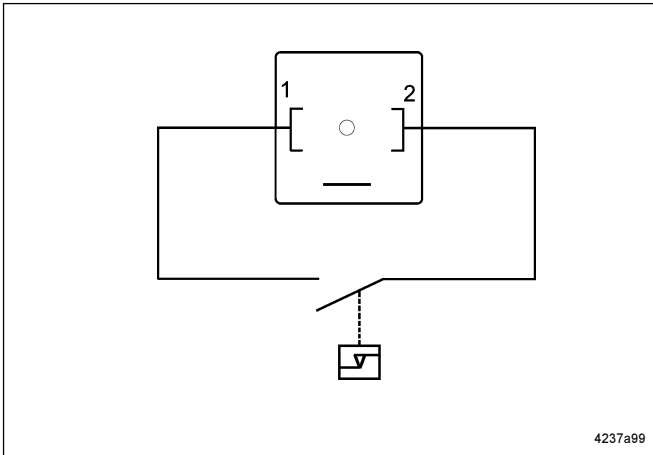

Fig. 17- Connecting diagram, pump for grease, magnetic floating switch

Pump for Oil

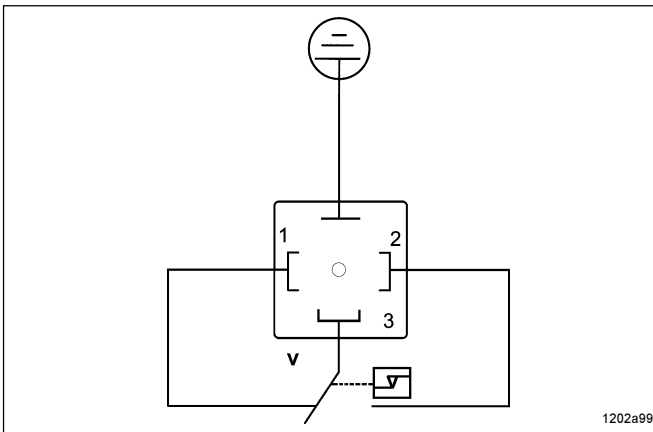

Fig. 18 - Connection diagram, pump for oil, magnetic floating switch

Magnetic floating switch

- The electromagnetic switch is activated contact-free and without wear by the magnetic field of the solenoid fitted to the float.

Note: The life of the magnetic circuit breaker strongly depends on the conditions under which it is loaded. Since the data relative to the maximum switching capacity refer to strictly resistive loads, which cannot be always guaranteed in practice, it is necessary to take the corresponding contact protection measures in the case of deviating loads.

Technical data:
 Maximum switching capacity: 60 VA
 Maximum switching voltage: 230 V
 Current switched: 3 A

Contact Protection Measures

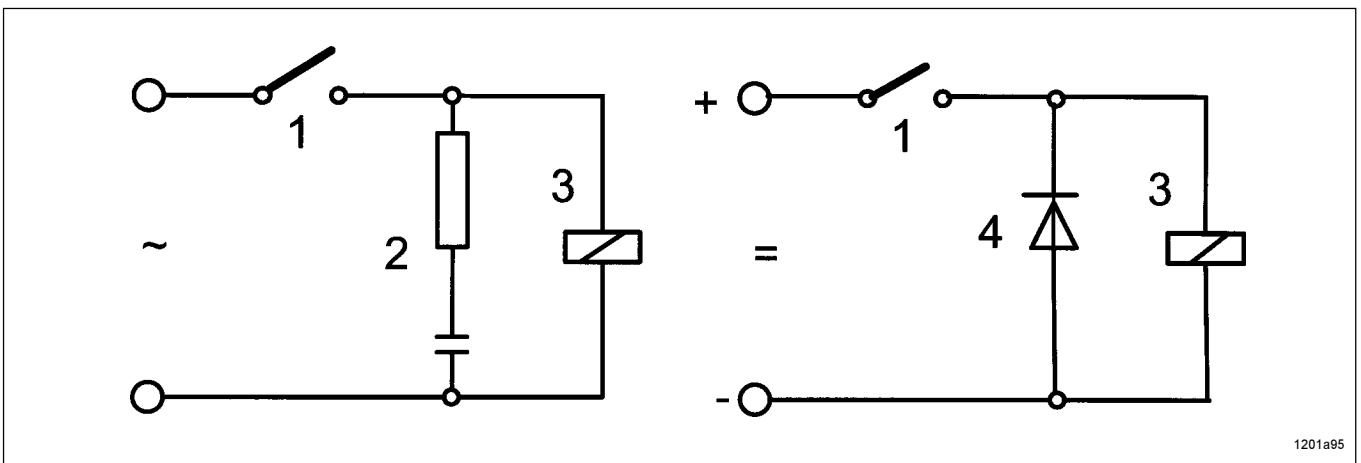

Fig. 19 - Contact protection measures
 1 - Electromagnetic switch
 2 - RC element
 3 - Diode
 4 - Load

Note: The life of the electromagnetic switch strongly depends on the conditions under which it is loaded. Since the data relative to the maximum switching capacity refer to strictly resistive loads, which cannot be always guaranteed in practice, it is necessary to take the corresponding contact protection measures in the case of deviating loads.

Subject to change without notice

Control p. c. b. V10 - V13 *

Mode of Operation

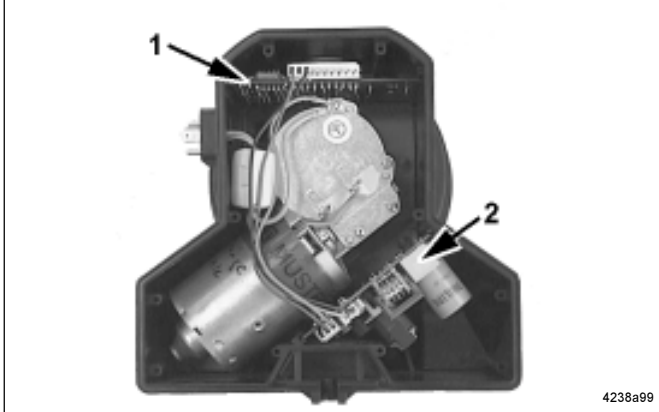

Fig. 20 - Printed circuit board in the pump housing.

- The printed circuit board 1 fig. 20 and the power supply board 2 are integrated in the pump housing.

1 - printed circuit board
 2 - power supply board

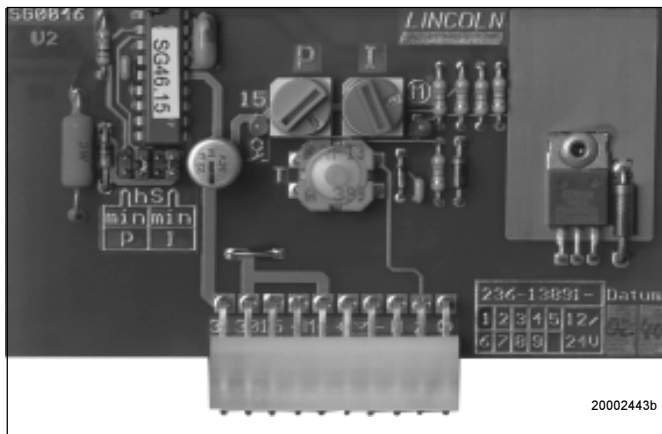

Fig. 21 - Printed circuit board 236-13891-1

- The printed circuit board automatically controls the sequence of the pause and operating times of the model 203 central lubrication pump as a function of the vehicle or machine working hours t_B , see fig.22.
- The sequence of the pause and operating times is activated when the machine contact is switched on .

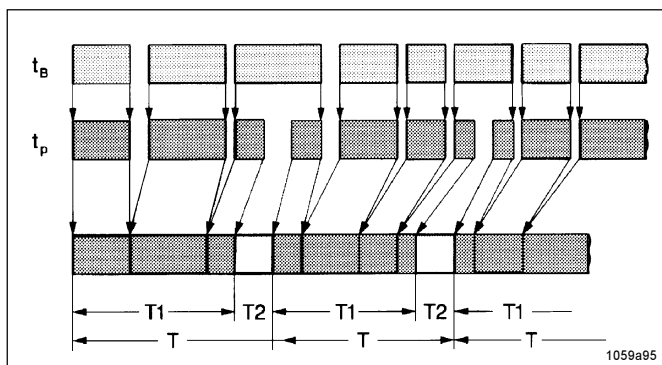

Fig. 22 -Time sequence diagram

t_B - Working hours
 t_P - Various pause times
 T - Lubrication cycle
 T1 - Stored pause times
 T2 - Operating times

- A lubrication cycle consists of one pause time and one operation time. Once the pause time has elapsed, the operating time starts to run. This lubrication cycle is repeated permanently after the machine or vehicle has been put into operation .
- During the operating time the pump element dispenses the lubricant to the Lubrication points via progressive metering devices.

* See the respective model designation on the pump nameplate e.g.
 P203 - 2XN - 1K6 - 24 - 1A1.10 - V10

The pause time

- determines the frequency of the lubrication cycles within a working cycle;
- is started and stopped via the machine contact or driving switch;
- is adjustable.
- When the machine contact or the driving switch is switched off, the pause times which have already elapsed are stored and added up (refer to T1, Fig.22) until the time which has been set on the blue rotary switch (Fig.25) is reached.
- The pause time setting may be different for each application. It must be adjusted in accordance with the respective lubrication cycles. Also see "To set the pause time".

The operating time

- depends on the system's lubricant requirement
- is adjustable
- is finished when the machine contact or the driving switch is switched off.
- When the machine contact or driving switch is switched off, the operating times which have already elapsed are stored and added up until the time which has been set on the red rotary switch is reached. After this, the lubrication cycle starts again.
- The operating time setting may be different for each application. It must be adjusted in accordance with the respective lubricant requirement. Also see "To set the operating time".

Time storage

- When switching off the operating voltage, the times already expired are saved for an unlimited duration.
- When the power supply is switched on again the printed circuit board continues to operate from the point where it had been interrupted.

Time Setting



Figure 23- The cover to access the printed circuit board has been removed

* To set the pause or operating time, remove the cover on the pump housing

Note : To reset a jumper (see fig 25 or 27), remove the printed circuit board .

Important: After having set the pause time or operating time, screw the cover on the pump house again.

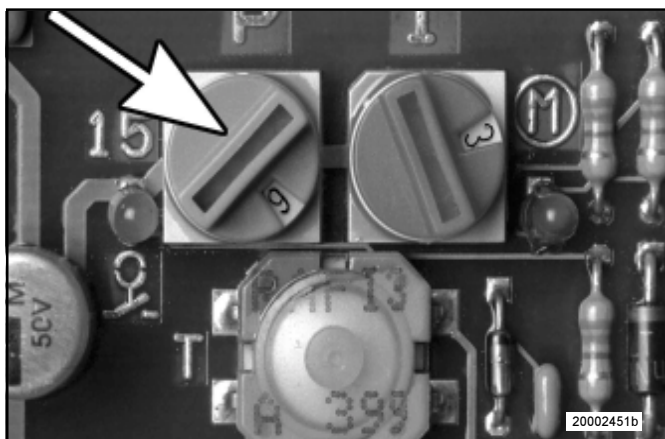

Fig 24 :Rotary switch - Pause Time

To set the pause time

- The pause time can be set to 15 different settings by means of the **blue rotary switch**

Time ranges: Minutes or hours

Switch time	1	2	3	4	5	6	7	8	9	A	B	C	D	E	F
Minutes	4	8	12	16	20	24	28	32	36	40	44	48	52	56	60
Hours	1	2	3	4	5	6	7	8	9	10	11	12	13	14	15

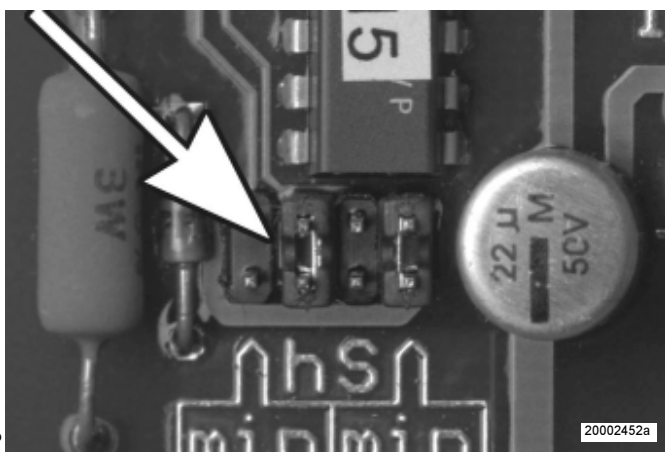

Fig. 25 - Preselection of the time range

Note: When the switch is on "0" a fault is shown at the right hand LED 3, see fig. 28.

At the same time the factory-set pause time is accepted.

Factory Setting

Rotary switch on 6 hours
 or 24 minutes

- The time ranges can be modified by replugging the jumper (Fig.25) on the printed circuit board.

	Pause time	Operating time
V10	1 - 15 h	2 - 30 min
V11	1 - 15 h	8 - 120 s
V12	4 - 60 min	2 - 30 min
V13	4 - 60 min	8 - 120 s

Subject to change without notice

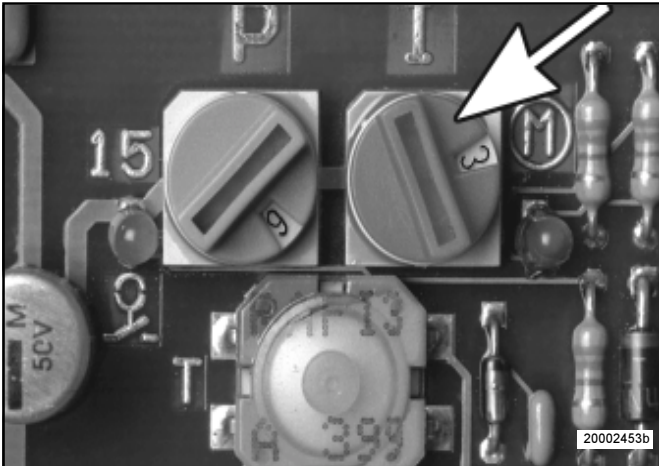

Fig.26- Rotary switch -operating time

To set the operating time

- The operating time can be set to 15 different settings by means of the red rotary switch.

Time Ranges : Seconds or minutes

Switch Position	1	2	3	4	5	6	7	8	9	A	B	C	D	E	F
Seconds	8	16	24	32	40	48	56	64	72	80	88	96	104	112	120
Minutes	2	4	6	8	10	12	14	16	18	20	22	24	26	28	30

Note: When the switch is on "0" a fault is shown at the right-hand LED 3 Fig. 28. At the same time the factory-set operating time is accepted.

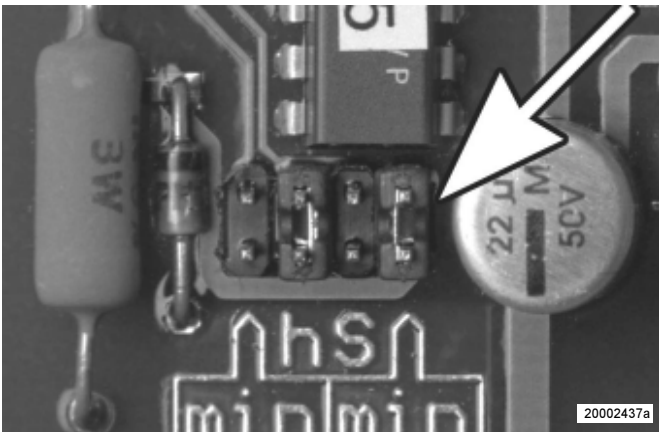

Fig. 27 - Preselection of the time range

Factory Setting

- The time ranges can be modified by replugging the jumper on the printed circuit board.

Rotary switch on 6 minutes
 or24 seconds

Fault indication

Rotary switch set at „0“

- When one of the rotary switches 2, 3 Fig. 28 is on the „0“ setting a fault is shown at the right-hand LED 3.
- The fault is indicated by 4 flashes of the LED.
- The pump motor also runs according the flash frequency. If the warning is ignored the controller automatically adopts the **factory-set** values for the operating or pause time

Pushbutton 5 Fig. 28 continuously actuated (short circuit)

- If a short circuit occurs at the pushbutton or is present at the external illuminated pushbutton Fig.13 or at the connecting parts a fault is shown at the red LED 3,
- The fault is indicated by 3 flashes of the LED when the voltage supply is switched on.
- The motor of the pump also runs according to the flash frequency.

Subject to change without notice

Repair

- The defective printed circuit boards should be suitable packed and returned to the factory
- **If the printed circuit board must be replaced , a model V 10 will always be delivered**

- Before installing another printed circuit board take care that the setting of the jumper or that of the operating/pause time is the same as on the old printed circuit board .

Operational Test / To Trigger an additional lubrication cycle

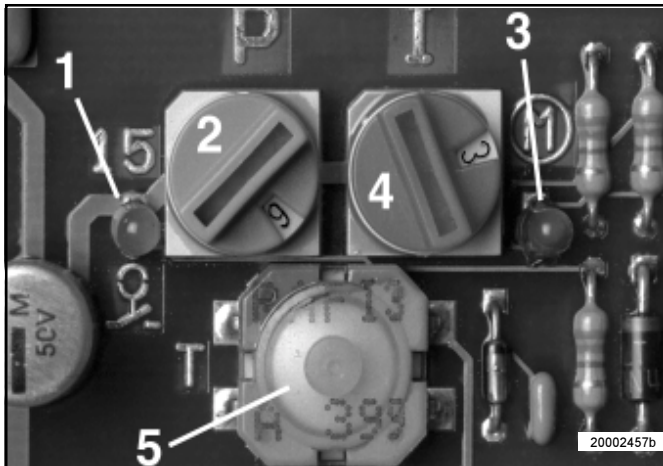

Fig. 28 - LED on the printed circuit board

- | | |
|-------------------------------|---|
| 1 - LED, left hand | 4 - Rotary switch, operating time |
| 2 - Rotary switch, pause time | 5 - Push button for an additional lubrication |
| 3 - LED, right hand | |

- To check the pump operation it is possible to perform an operational test.
- To check whether power is applied to the printed circuit board, observe whether the LED 1 Fig. 28 is lit.
- * Press pushbutton 5 on the printed circuit board (> 2 seconds) until the right-hand LED 3 lights up.
- A shorter pause time elapses, followed by a normal lubrication cycle.
- Additional lubrication cycles can be triggered at any time.

Maintenance, Repair and Tests

Maintenance

- The maintenance is essentially limited to refilling the reservoir with clean lubricant in good time. However, check regularly whether the lubricant is really dispensed to all the lubrication points.
- Also check the main lines and lubricant feed lines for damage and replace them, if necessary.

Note: Whenever work is done on the centralized lubrication system, particular attention should be paid to absolute cleanliness. Dirt in the system will cause problems.

- For cleaning the system use benzine or petroleum. Do not use tri-, perchloroethylene or similar solvents. Also do not use polar organic solvents such as alcohol, methylacohol, acetone or similar

Pump Filling



Fig. 29 - Filling up the reservoir

2 l - reservoirs

Fill the reservoir up to the "Max." mark via the filling nipple, if any, or via the upper filling opening.

4 l , 8 l - reservoirs

Fill the reservoir up to the "Max." mark via the upper filling opening.

It is possible to use greases up to penetration class NLGI 2 or mineral oils of at least 40 mm²/s (cST).

Important! The grease or oil must be free from impurities and must not be liable to change its consistency in the course of time.

Attention: If the pump is filled via the upper filling opening, switch off the power supply before starting filling.



Attention: When filling the reservoir by means of pumps with a large delivery volume do not exceed the max. filling mark. Risk of bursting if the reservoir is overfilled.

Note: If the reservoir has been completely emptied, the pump may require until 10 minutes before it operates with its full output.

Repair

Pump



Switch off the voltage supply before servicing

- Use only original LINCOLN spare parts for repair on the pumps.
- The pump should be returned to the factory for warranty work or major repairs.
- Defective printed circuit boards should be suitably packed and returned to the factory.

Replace the pump element

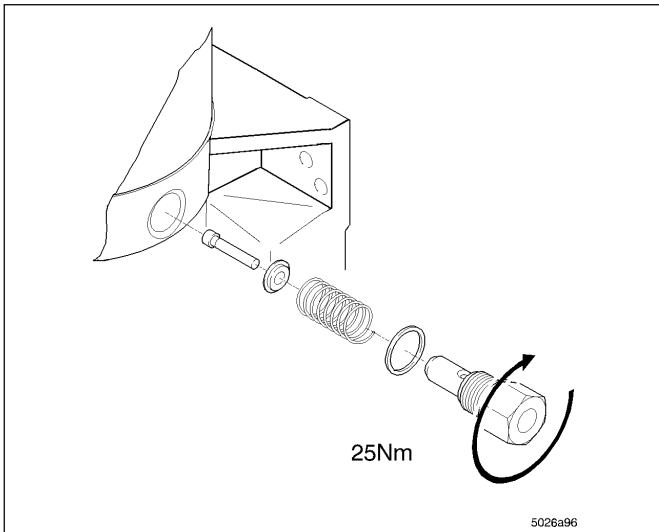

Fig. 30 - Replacing the pump element

- * Remove the pressure relief valve from the pump element
- * Unscrew the pump element. Take care that the piston, the pull-back spring and the washer are not left lying in the grease, otherwise the reservoir must be disassembled in order to remove these pieces.

Important: Do not leave the piston, spring and washer in the housing because they may block the motor.

- * Install a new pump element and a new sealing ring

Note: Pump element with adjustable lubricant output is set to the same output as the old pump element

Tests

Operational Test / Triggering an Additional Lubrication Cycle

- To check the pump operation it is possible to perform an additional test. Refer to the Technical Description of the respective printed circuit board.

To Check the Pressure relief valve

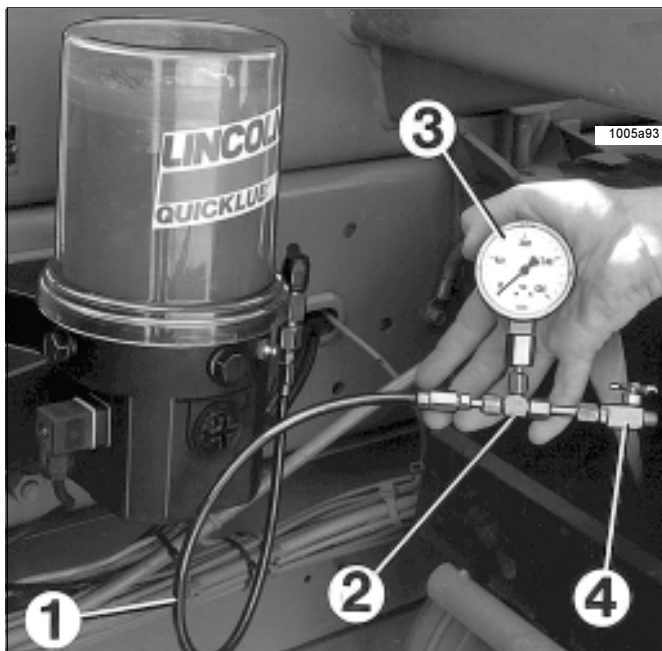

Fig. 31 - To check the safety valve

- 1 - Hose line, min. length 1m
- 2 - T-piece
- 3 - Pressure gauge
- 4 - Relief cock

1st option

- * Connect the pressure gauge (0-600 bar; 0-8708 psi) to the pressure relief valve (Fig. 31).
- * Trigger an additional lubrication cycle.

2nd option

- * Connect the manual pump of the pressure and checking set 604-36879-1 to the pressure relief valve and check the opening pressure by means of the manual pump.
- * The pressure relief valve should open at a pressure of 250 or 350 bar depending on its design.

Important : Do not connect the pressure gauge directly to the pump element. High pressure may exceed the above mentioned range, causing the motor to stall. The motor is designed in such a way that it can stall for about 30 minutes without being damaged.

Troubleshooting

*Note: The pump operation can be checked from the outside by observing whether the stirring paddle is rotating (e.g. by triggering an additional lubrication). For troubleshooting in the case of pumps with integrated control units, please refer to the **paragraph** of the printed circuit board.*

• Fault: The pump motor does not run	
• Cause:	• Remedy:
<ul style="list-style-type: none"> • Power supply interrupted • Electric motor defective 	 <ul style="list-style-type: none"> • Check the power supply and fuses. If necessary rectify the fault and/or replace the fuses. • Check the line leading from the fuses to the pump plug. • Check the power supply to the motor. If necessary, replace the motor.
• Fault: The pump does not deliver the lubricant	
• Cause:	• Remedy:
<ul style="list-style-type: none"> • Reservoir empty • Air bubbles in the lubricant • Unsuitable lubricant has been used • Suction hole of the pump element clogged • Pump piston worn • Check valve in the pump element defective or clogged. 	<p><i>Note: If a lubricant low-level is available, the low level is indicated by the flashing light of the signal lamp in the case of pumps without printed circuit board. The flashing frequency depends on the speed of the motor.</i></p> <ul style="list-style-type: none"> • Fill up the reservoir with clean grease or oil. Allow pump to run (trigger an additional lube cycle) until the lubricant issues from all the lubrication points. <p><i>Note: Depending on the ambient temperature and/or sort of lubricant it may take 10 minutes of operation before the pump elements reach their full lubricant output.</i></p> <ul style="list-style-type: none"> • Trigger an additional lubrication cycle. Loosen the outlet fitting or the main line at the pressure relief valve. The lubricant must issue without air bubbles. <p><i>Note: When push-in type fittings are used, the high-pressure plastic hose which is under pressure cannot be easily disconnected from the safety valve. For this purpose, loosen the pressure relief valve or filling nipple on the pressure relief valve in order to relieve the high-pressure hose.</i></p> <ul style="list-style-type: none"> • Renew the lubricant. See the Lubricant List. • Remove the pump element. Check the suction hole for foreign particles. If there are any, remove them. • Replace the pump element. • Replace the pump element.

Subject to change without notice

Technical Data

Pump

Admissible operating temperature -25° C to 60° C*
Number of outlets 1,2 or 3
Reservoir capacity 2 l, 4 l, 8 l
Refilling via hydraulic lubrication fitting or from top
Lubricant greases up to NLGI grade 2
..... mineral oils of at least 40mm²/s (cST) at 40° C
Class of protection IP6K 9K acc. DIN 40050 T9

**Note: The pump is designed for the above mentioned temperature range. The lubricants used must still be pumpable at the temperatures mentioned above. In case of doubt, consult the lubricant manufacturer.*

Electrical data

Input

Input voltage 94 - 265 VAC; 47 - 63 Hz
Input current 200 mA at 230 VAC
Fuse T 1,25 A/250 V internal

Output

Output voltage 24 VDC +/- 1 %

Protection and monitoring

Current limiting resistant to sustained short circuit
Overload-proof yes
Idling-proof yes
Mains buffering time > 15 ms at 230 VAC

Safety VDE 085/11.93/EN 60950/ICE 950, EN 60204

Output Safety extra-low voltage (SELV)
Class of protection class 1
Degree of protection IP6K9K (installed in pump housing)
Discharge current < 0,25 mA (47 - 63 Hz U_{IN} max.)

EMC

Radio interference suppression VDE 0875 T 11, EN 55011 class A
Emitted interference acc. EN 50081/2
Noise immunity acc. EN 50082/2

Note: The emitted interference meets the requirements for the industrial sector, if used in the residential sector this may possibly lead to interference.

Operational data

Temperature range -25 to 60 ° C
Derating 2,5 %/K
..... from 60° C on to max. 70° C (max. 30 minutes)
Storage temperature -25 ° C to 80 ° C
Pump operating time 30 minutes max.

Electrical connection:

Before starting, be sure that all connections are off circuit. The device may not be connected or disconnected under voltage. The protective conductor must always be connected. For this, use a sufficient line cross section conforming to standards and ensure safe contacting.

Internal fuse

If internal fuse has to be replaced, use only the original type.

Motor:

DC gear Motor - (interference - suppressed)

Operating Voltage 24VDC
Max. Current input
24V 3 A
Speed approx. 17 rpm

Note: The pump motor is designed for intermittent operation.

Printed Circuit Board

Rated voltage 24V DC
Temperature range -25°C to 60°C
Class of protection
Printed circuit board installed in housing IP 6K 9K

In order to protect the printed circuit board against condensation it has been covered with a protective varnish.

Time settings for pumps with p. c. b.

Pause time, depending on the jumper position:
 4, 8, 12; to 60 minutes
 1, 2, 3...to 15 hours
 Operating time, depending on the jumper position:
 8, 16, 24;... to 120 seconds
 2, 4, 6,... to 30 minutes
 Factory setting
 Pause time 6 hours
 or 24 minutes
 Operating time 6 minutes
 or 24 seconds

Torsion torques

Install pump 18 Nm
 Electric motor on housing 12 Nm
 Pump element in housing 25 Nm
 Closure plug in housing 12 Nm
 Return line connector in housing 10 - 12 Nm

Weights

The weights below include the following “**individual weights**”:
 - Pump kit with **one** pump element, safety valve, grease filling
 and power supply board (0.75 kg, 1.5 kg)
 - Packing (cardboard box)
 - Attaching parts
 - Operating Instructions

2 l reservoir, standard design (0.75 kg)

Pump 203 without connection cable 5.6 kg
 Pump 203, version 1A 1 6.7 kg
 Pump 203, version 2A 1 7.3 kg

4 l reservoir, standard design (1.5 kg)

Pump 203 without connection cable 8.5 kg
 Pump 203, version 1A 1 9.5 kg
 Pump 203, version 2A 1 10.1 kg

8 l reservoir, standard design (1.5 kg)

Pump 203 without connection cable 8.8 kg
 Pump 203, version 1A1 9.8 kg
 Pump 203, version 2A1 10.4 kg

Pump element with fixed lubricant output

Piston diameter, K5 5 mm
 Lubricant output approx. 2 cm³/min
 Piston diameter, (standard) K6 6 mm
 Lubricant output approx. 2.8cm³/min
 Piston diameter, K7, C7 7 mm
 Lubricant output approx. 4 cm³/min
 Max. operating pressure. 350 bar
 Connection thread. G 1/4
 suitable for tube DIA 6 mm

Important! The lubricant output listed refers to grease of NLGI grade 2 measured at 20°C, backpressure 100 bar. Any differing pressures or temperatures result in different lubricant outputs. Any system design must be based on the above values.

Pump element with adjustable lubricant output

KR 0.04 to 0.18 cm³/stroke
 0.7 to 3 cm³/min
 Connection thread G 1/4
 suitable for tube DIA 6 mm
 suitable for tube DIA 8 mm

Safety valve

SVEVT - 350 - G 1/4 A - D6 624-28070-1
 SVEVT - 350 - G 1/4 A - D8 624-28774-1

In the case of pump versions deviating from those mentioned, add the weights of the following components to the mentioned weights.

Per pump element +0.2 kg
 Per safety valve +0.1 kg

Reservoir version “Filling from top” (only 2 l)* +0.15 kg
 2 l flat-type reservoir +0.5 kg

* *Note: The 4l and 8l reservoirs have the standard design “filling from top”.*

Electrical Connection Diagrams

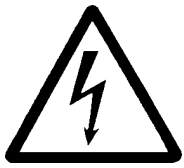

Caution: Before starting, be sure that all connections are off circuit. The device may not be connected or disconnected under voltage. The protective conductor must always be connected. For this, use

a sufficient line cross section conforming to standards and ensure safe contacting

* Connect the cables according to the connection diagrams below.

Note: The IP6K9K class of protection is only guaranteed if the connection plug including the gasket is tightened.

Diagram of connections - Pump without p. c. b.

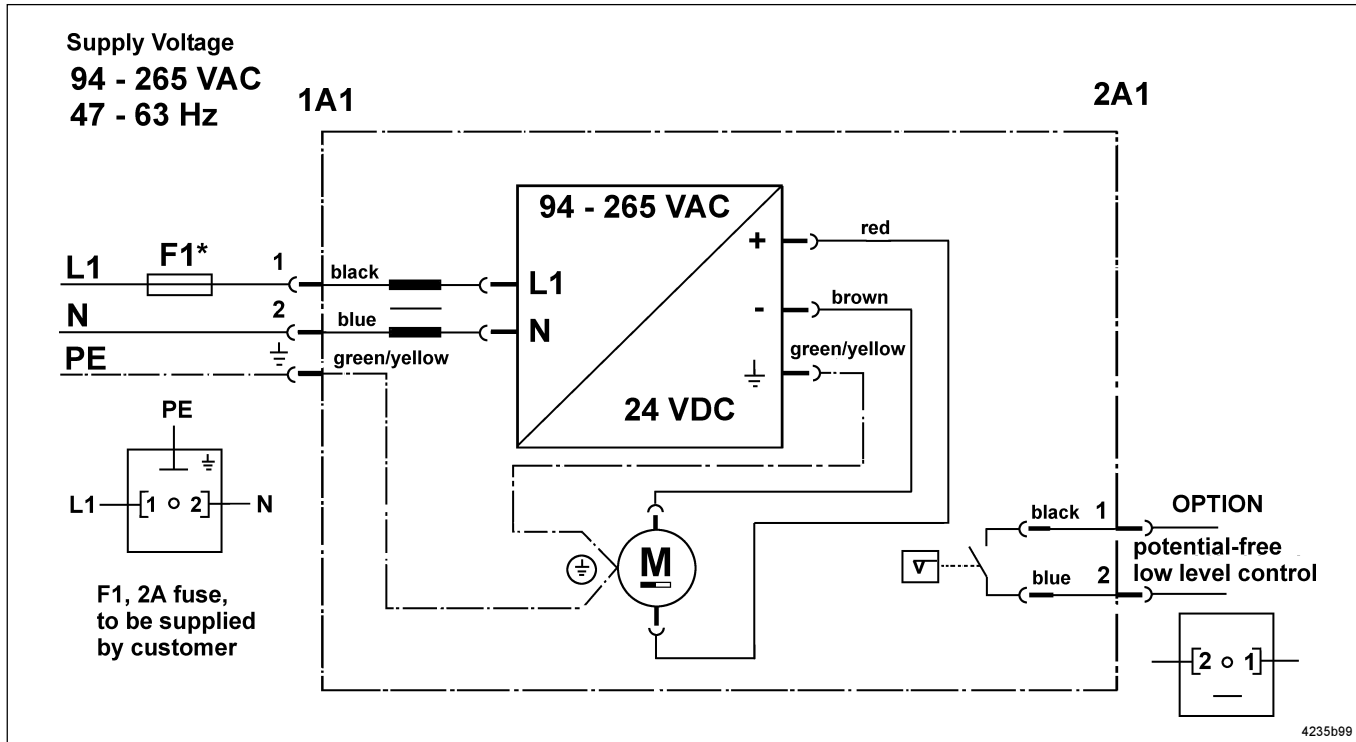

Fig. 32 - Diagram of connections of QUICKLUB 203 without p. c. b.
 Connection by means of a square type plug, DIN 43650-A

Note: For the connection of the low level control also see the diagrams of connections and contact protection measures on page 13.

Diagram of connections - Pump with V 10 - V 13 p. c. b.

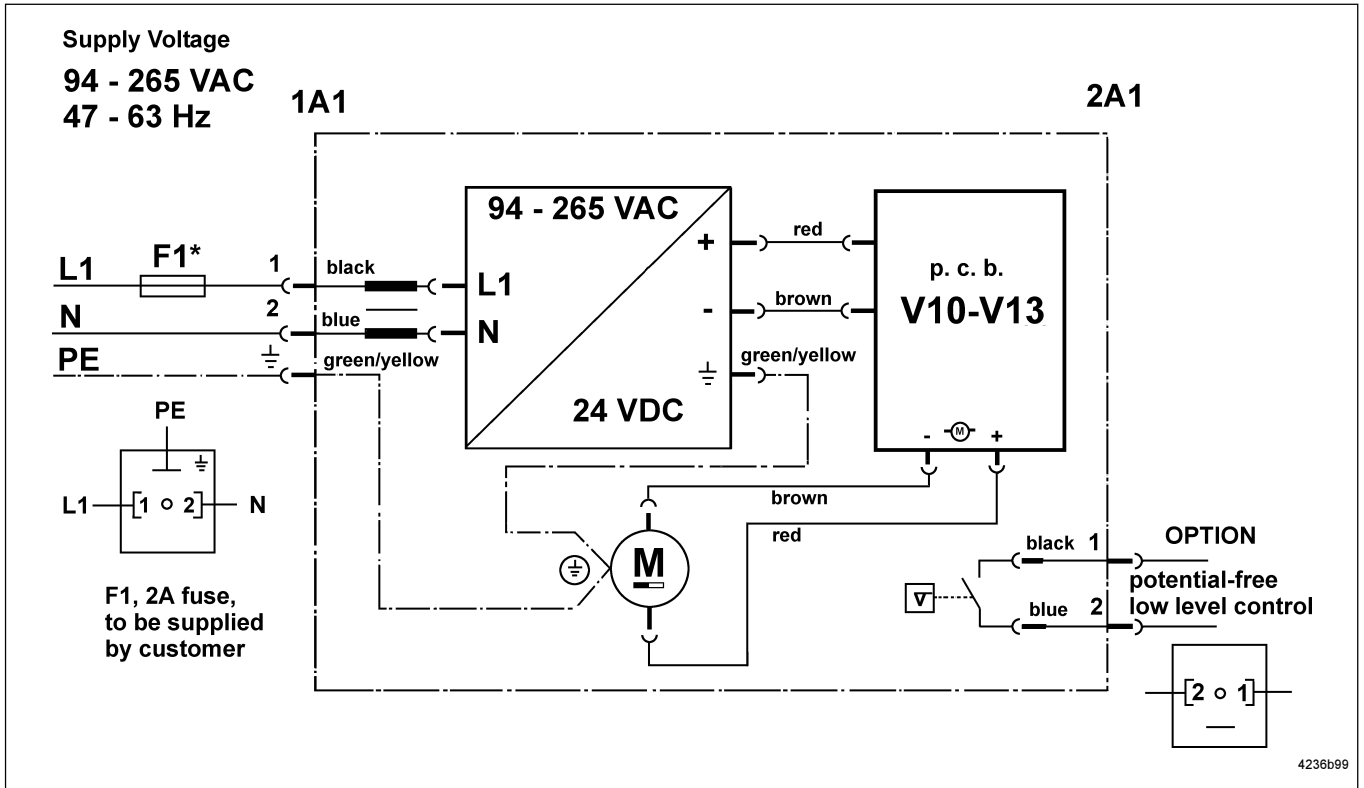
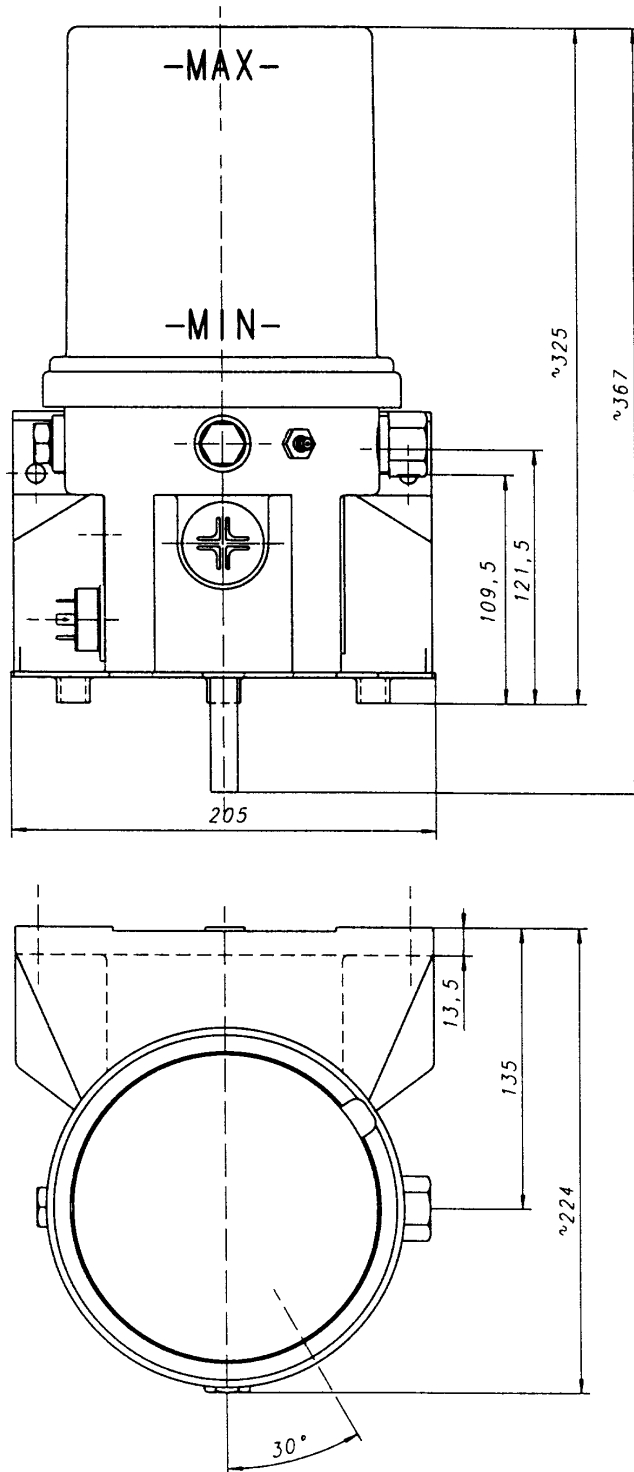

Fig. 33 - Diagram of connections of QUICKLUB 203 with p. c. b.
 Connection by means of a square type plug, DIN 43650-A

Note: For the connection of the low level control also see the diagrams of connections and contact protection measures on page 13.

Dimensions

2 | Reservoir



1166a95

2 | Reservoir with Filling from Top

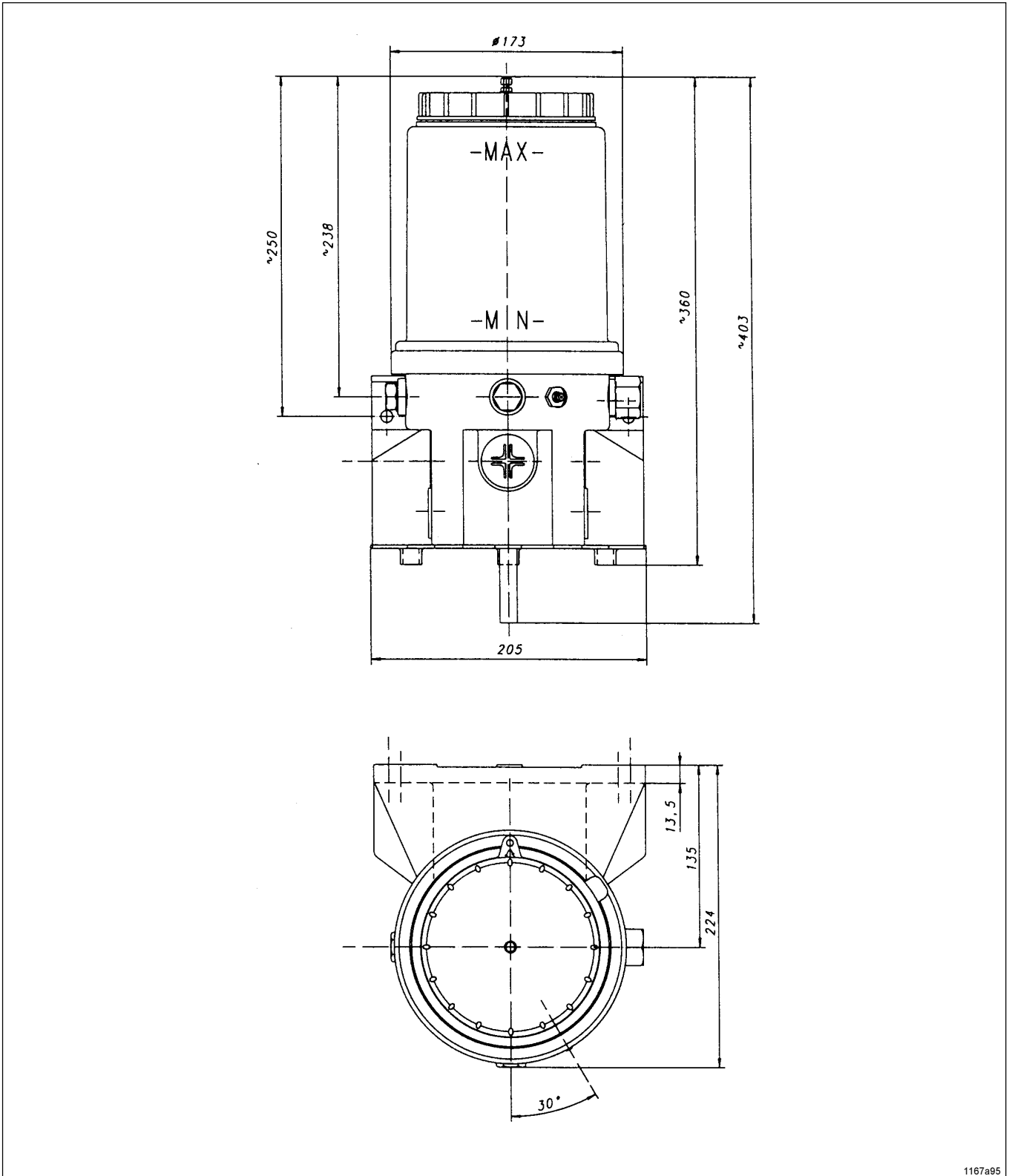

Subject to change without notice

1167a95

2 | Flat-Type Reservoir

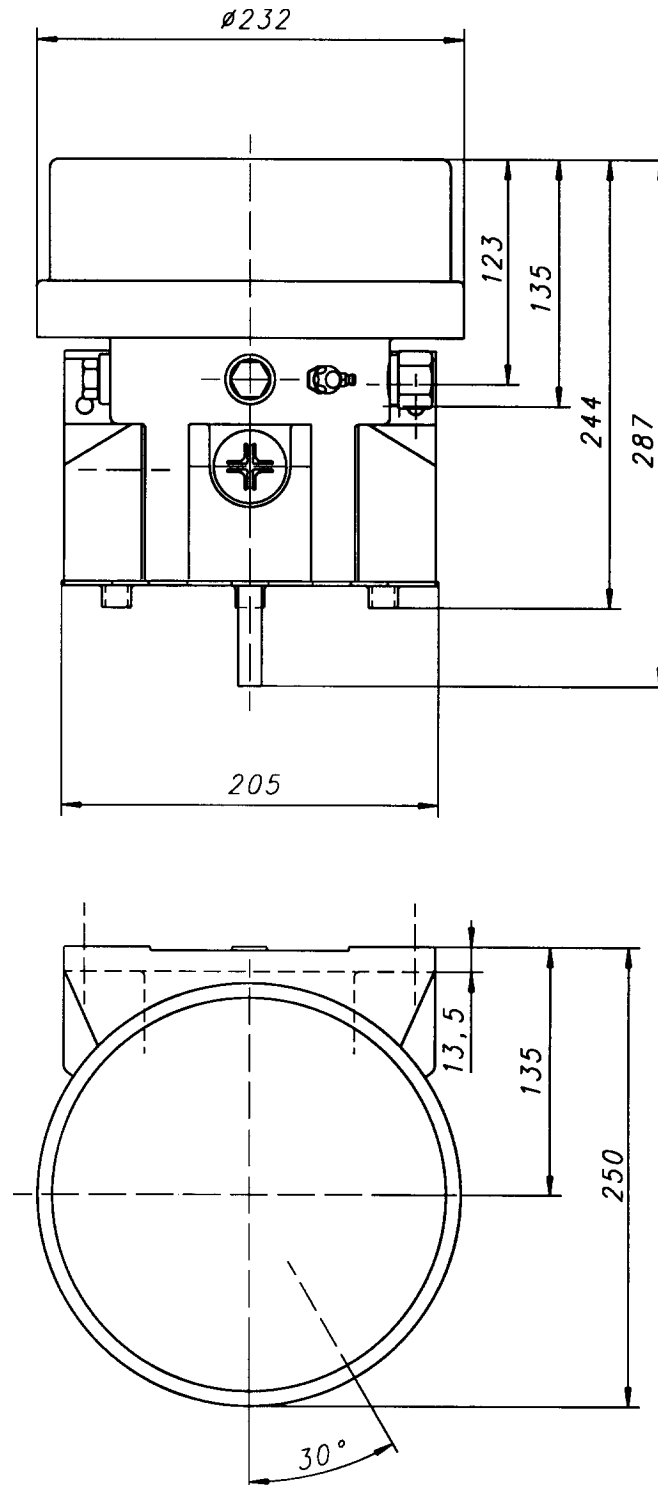

1168a95

4 | Reservoir

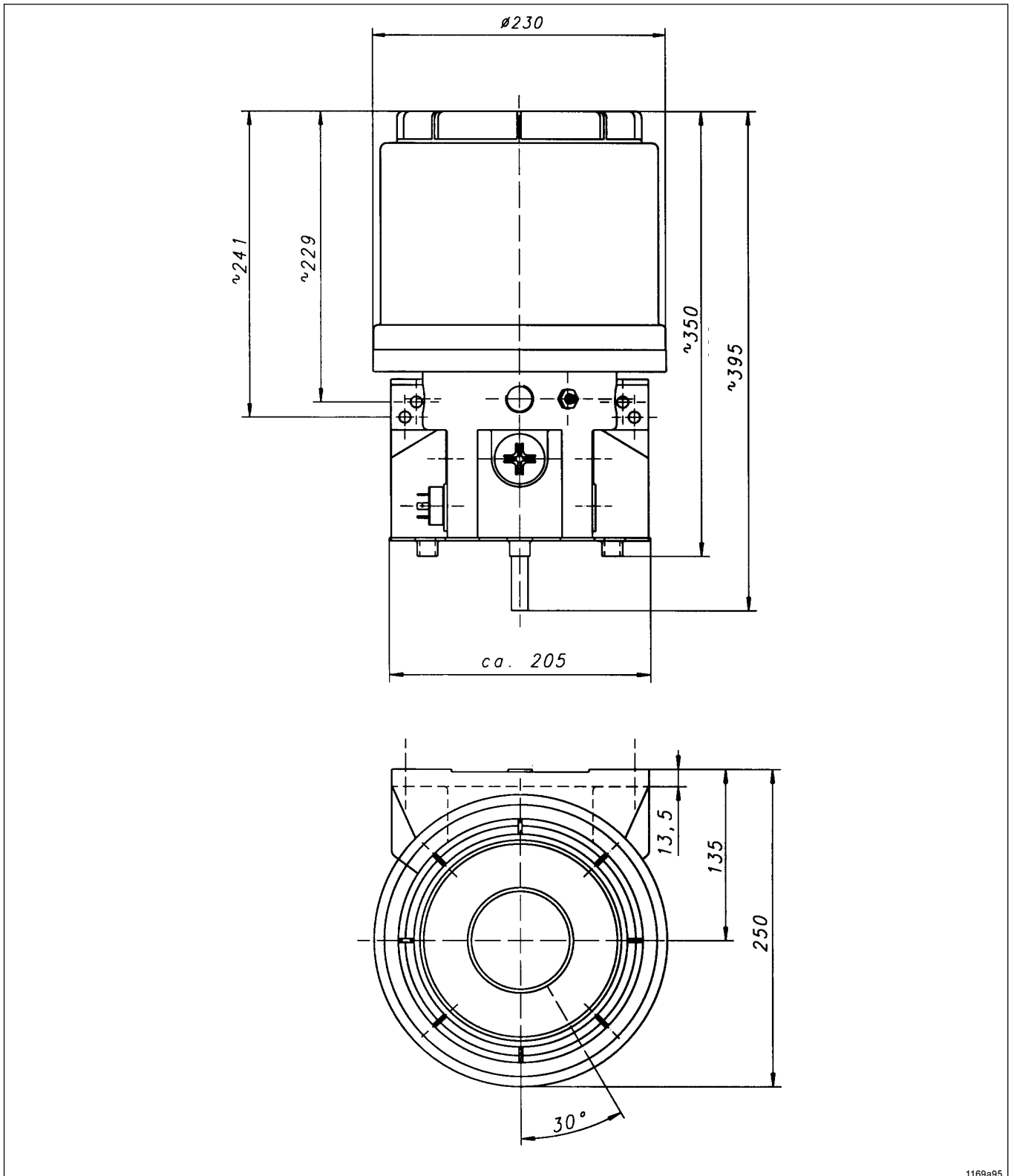

Subject to change without notice

1169a95

8 | Reservoir

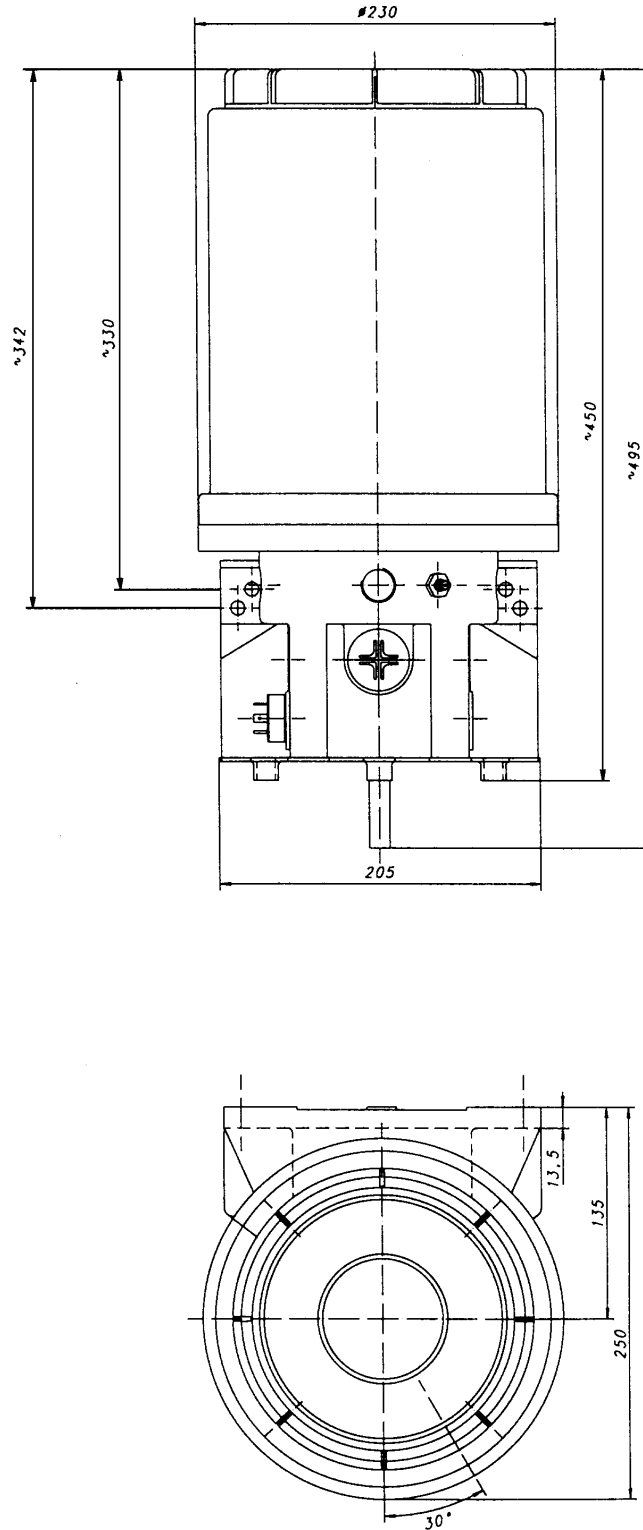

1170a95

Attaching Boreholes of the 2l, 4l, 8l, Pump

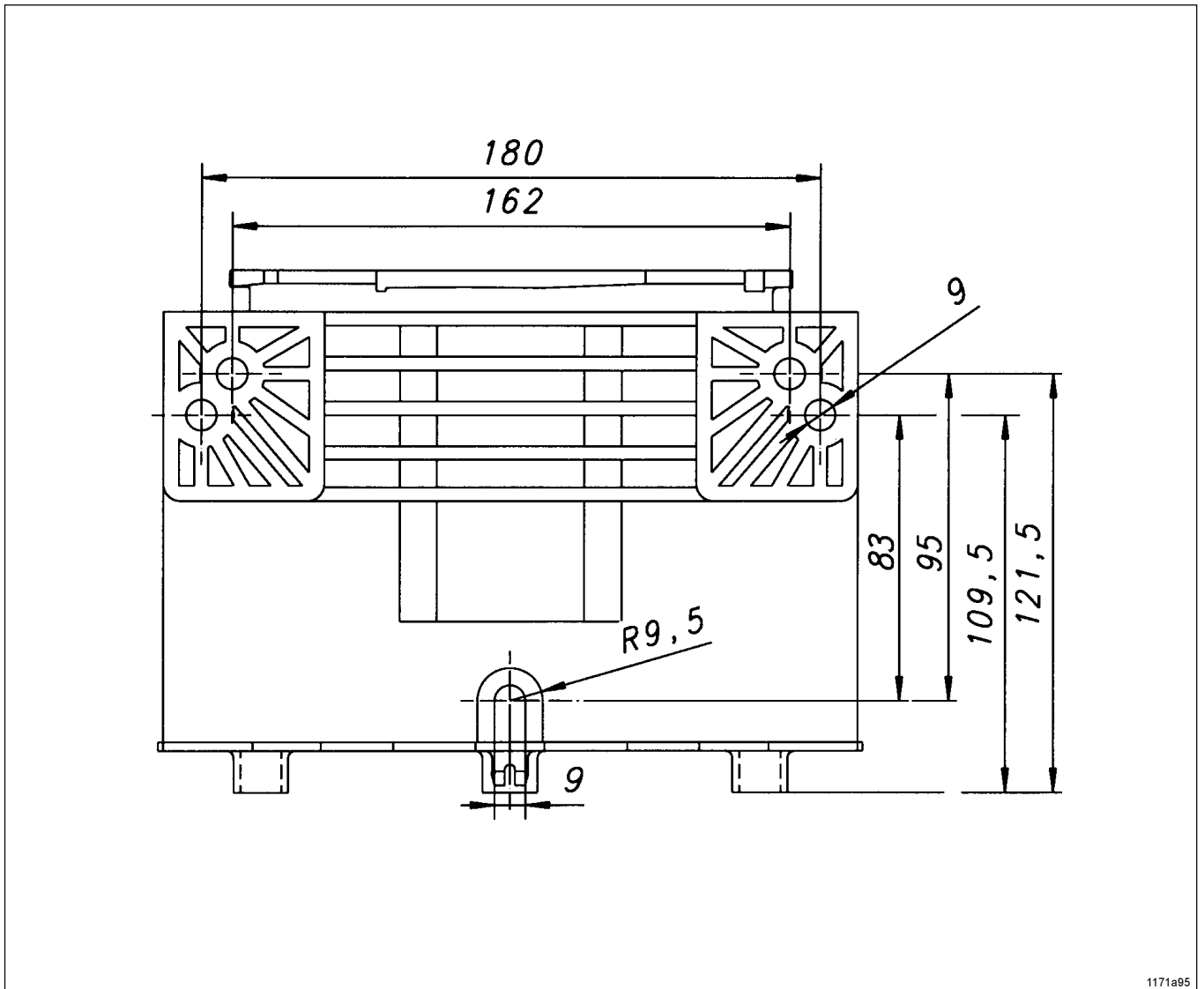

1171a95

Note: Tighten pump models with 2 l - flat, 4 L - and 8 L reservoir with three fastening screws (see pt .9,5)

Lubricants

The pump QUICK LUB 203 can dispense commercial greases up to NLGI grade 2 or mineral oils of at least 40 mm/s (cSt) at 40 ° C.

Important : Absolute cleanliness is essential when handling Lubricants. Impurities will remain suspended in the lubricant and cannot settle. This will result in damage to the lubrication system and thus to the bearing

Lubricating greases for QUICKLUB systems

Manufacturer	Designation	Base soap	min. delivery temperature
AGIP	F1 Grease 24	Ca	
ARAL	Multipurpose grease ZS 1/2	Ca/Li	-20 ° C
AUTOL	Top 2000	Ca	-10 ° C
AUTOL	Top 8000 W	Ca	-20 ° C
BP	Lubrication grease	Ca	
BP	C1 Lubrication grease	Ca	-20 ° C
CASTROL	CLS - Grease	Ca/Li	
ESSO	Cazar K2	Ca	
ESSO	High pressure grease	Ca	
FIAT LUBRIFICANTI	Comar 2	Li	-25 ° C
FINA	Ceran LT	Ca	-20 ° C
FINA	Ceran WR2	Ca	
FUCHS	FN 745	Ca	-25 ° C
FUCHS	LZR 2H	Li	-20 ° C
FUCHS	Renocal FN3	Ca	-20 ° C
FUCHS	Renolit HLT 2	Li	-25 ° C
KLÜBER	Centoplex 2 EP	Li	
MOBIL	Mobilgrease	Li	-30 ° C
MOLYKOTE	TTF 52	anorg. Verd.	-30 ° C
OPTIMOL	Longtime PD 2	Li	- 20 ° C
OPTIMOL	OLIT CLS	Li/Ca	- 15 ° C
SHELL	Retinax C	Ca	
WESTFALEN	Gresalit ZSA 2	Li	-15 ° C
ZELLER & GMELIN	ZG 450	Li	
ZELLER & GMELIN	ZG 736	Li	

Bio-degradable greases

Manufacturer	Designation	Base soap	min. delivery temperature
ARAL	BAB EP 2	Li/Ca	
AUTOL	Top 2000 Bio	Ca	-25 ° C
AVIA	Biogrease 1	Li	bis 0 ° C
DEA	Dolon E 2	Li	-15 ° C
FUCHS	Plantogel S2	Li/Ca	
KLÜBER	Klüberbio M32 - 82	Ca	-20 ° C

Use Lubricants with solid matter additives only after having consulted the manufacture system.