

Table of Contents

Safety Instructions 1
 Proper Use..... 2
 Structure 3
 Mode of Operation 4
 Technical Data 5
 Electrical Equipment 5
 Erection and Assembly..... 5
 Operation Instructions 5
 Commissioning 5
 Settings 6
 Maintenance and Repair..... 7
 Troubleshooting 7
 Repair of the Pump Tube 8
 Spare Parts for Hydraulic Pump 9
 Sealing kit on the oscillating cylinder 10
 Spare Parts Drawing Pump Tube 12
 Spare Parts List Pump Tube 13

commissioned. The Operating Instructions must always be available on the site where the machine/system is installed.

- All general safety instructions contained in this main chapter on safety must be observed as well as all special safety instructions given in other main chapters.

Hazard marking in the Operating Instructions



Safety symbol acc. to DIN 4844-W9

- The notes referring to safety contained in the Operating Instructions whose failure to observe them may result in personal injury are marked by the symbol above.

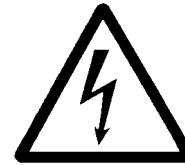

Safety symbol acc. to DIN 4844-W9

- This symbol warns of an electrical current

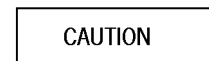

- If ignoring the safety note might result in machine damages and malfunction, the word **CAUTION** is added.
- Warnings directly fixed to the machine must always be observed and must be kept in completely legible condition.

Staff Qualification and Training

- The staff responsible for operation, maintenance, inspection and installation must be adequately qualified for these jobs.
- The user must properly regulate the field of responsibility and supervision of the personnel.
- If the personnel is not in command of the necessary expertise, they must receive the appropriate training and instructions. If necessary, this can be done by the manufacturer/supplier on behalf of the machine user

Preface to the Owner's Manual

- **The Owner's Manual**
 - Manual is intended to familiarize the user with the pump/lubrication system and to enable him to use it adequately.
 - must always be available on the site where the pump/lubrication system is in operation.
 - must be read and used by all persons who are charged with work with the pump/lubrication system, e.g.
- **Operation**, including adjustment, troubleshooting during operation, elimination of production waste, maintenance, disposal of process materials
- **Maintenance** (inspection, repairs)
- **Transport**

Persons who **do not have a good command of the English language** must be informed by the user of the pump/lubrication system on the **contents of the Owner's Manual, particularly the Safety Instructions, before they carry out the work.**

The Operating Instructions

- contain important information for the safe, correct and economic operation of the pump/lubrication system.
- will help avoid hazards.
- reduce repair costs and downtime.
- increase the reliability and prolong the service life of the pump/lubrication system.
- must be supplemented by the respective national regulations concerning the prevention of accidents and protection of the environment.

Safety Instructions

- The Operating Instructions include general instructions which must be followed when a pump/lubricating unit is installed, operated or serviced. Therefore, it is absolutely necessary for the fitter and the specialist/user to read the Operating Instructions before a unit is installed and

Furthermore, the user must ensure, that the contents of the Operating Instructions are fully understood by the personnel.

Hazards resulting from failure to observe the safety instructions

- Failure to heed the safety warnings may result in damage to equipment and the environment and/or personal injury.
- Failure to observe the safety notes may result in the loss of all claims for damage.
- As an example, in the following we list some dangers which may result from failure to observe the warnings:
 - failure of machine/system to fulfill important functions
 - failure of specified methods for maintenance and repair
 - personal injury due to electrical, mechanical and chemical influences
 - danger to the environment due to leakage of harmful materials

Safety-Conscious Working

- Observe
 - the safety instructions given in the Operating Instructions
 - the prevailing national regulations for the prevention of accidents
 - any working and shop regulations and accident prevention measures of the user

Safety Instructions for the User/Operator

- If warm or cold machine parts may involve hazards, the customer must protect them against accidental contact.
- Do not remove protection devices for moving parts while the machine is in operation
- Leakages of harmful materials must be disposed of so as to jeopardize neither persons nor the environment. The requirements of the law must be satisfied.
- Danger caused by electrical current must be excluded (for details refer to the applicable specifications of VDE and the local power supply companies).

Safety Instructions for Maintenance, Inspection and Installation Services

The user must make sure that all maintenance, inspection and installation work is executed by authorized and qualified experts who have thoroughly read the Operating Instructions. On no account may work be done on the machine while the machine is in operation. Follow all instructions for shutting down the machine as described in the Operating Instructions. Decontaminate pumps and pump units delivering harmful materials.

Reassemble all safety and protection devices immediately after completion of the cleaning procedure.

Dispose of material harmful to the environment in accordance with the applicable official regulations.

Before putting the pump/pump unit into operation, ensure that all points given in the chapter "Commissioning" are fulfilled.

Unauthorized Modification and Spare Parts Production

Alteration and modifications of the machine are only allowed if approved by the manufacturer. Original spare parts and accessories authorized by the manufacturer ensure safe operation. If other parts are used, the manufacturer may be released from its liability for the resulting consequences.

Appropriate use

The hydraulically operated drum pumps are designed only for use in centralized lubrication systems for the supply of grease.

Do not exceed the limit values mentioned in the Technical Data, particularly the max. input pressure for hydraulic oil (160 bar) and the max. operating pressure of 280 bar.

Any other use is not in conformity with the intended purpose and will result in the loss of claims for warranty and liability.

This Owner's Manual only refers to the hydraulic drum pump model 609-28839-1.

It is intended for the installation, operation and maintenance personnel.

If you need more information than given in this Owner's Manual, please contact LINCOLN GmbH and indicate the precise type designation (mentioned on the nameplate).

Structure

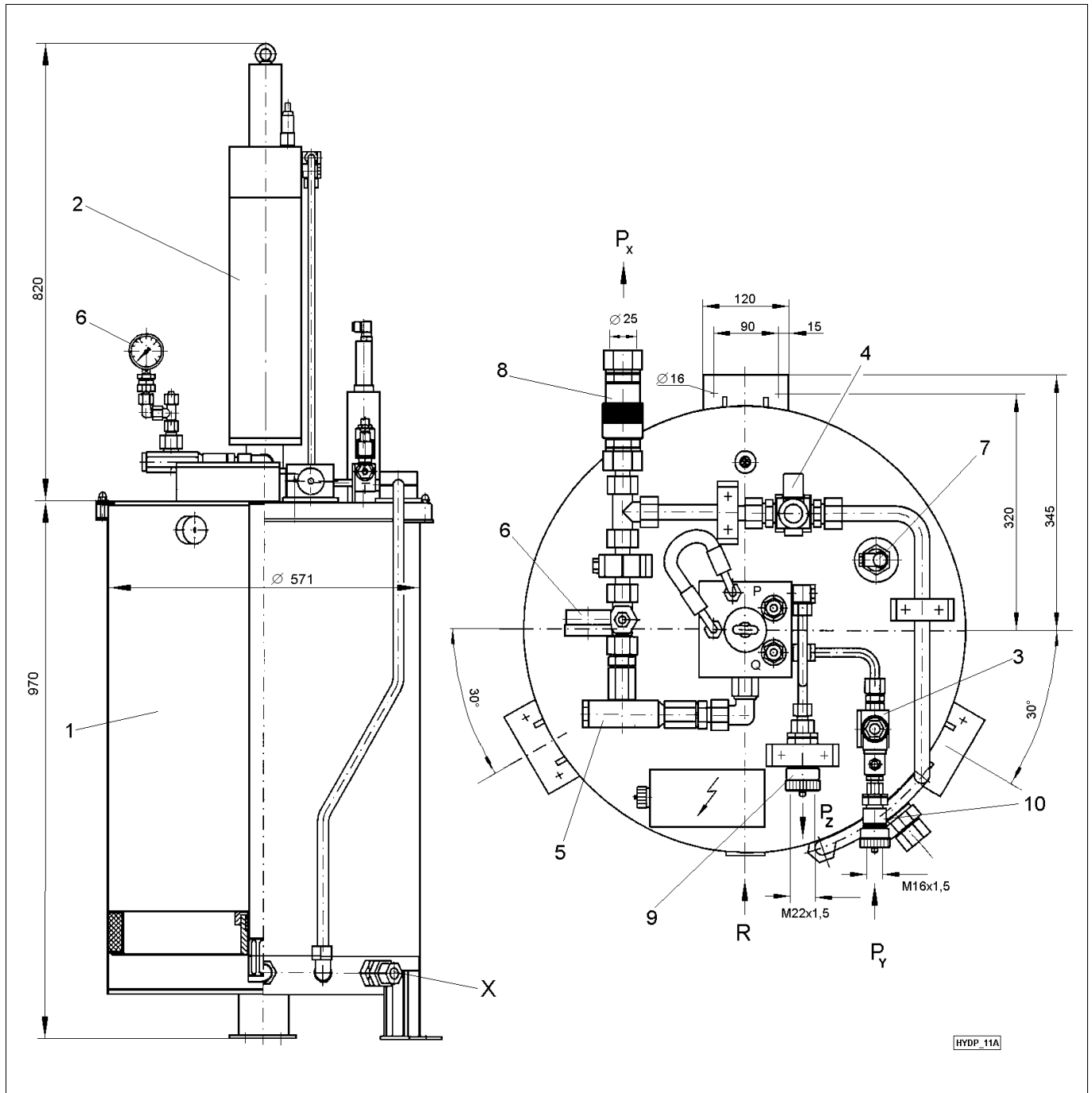

Fig. 1: General view

- | | | |
|----------------------------|---------------------------------|----------------------|
| Px: Grease outlet | Q: Flow regulating valve | Pz: Hydraulic outlet |
| Py: Hydraulic inlet | R: Filling connection R 1" fem. | |
| P: Pressure reducing valve | X: Overfilling safety valve | |

The pump 609-328839-1 consists of the following main components:

Item	Description	Part-No.	Item	Description	Part-No.
1	Grease reservoir assy.	509-32181-1	6	Pressure gauge 0-400 bar Ø63	234-13132-7
2	Hydraulic pump assy.	509-32178-1	7	Level indicator (sonar-sensor)	664-36973-1
3	2/2-way solenoid valve (hydraul.)	235-13181-5	8	Quick coupling DN 20	226-13690-9
4	2/2-way solenoid valve (grease)	235-13174-1	9	Quick action screw socket M22x1,5	980058-E
5	Grease filter	084004	10	Quick action screw socket M16x1,5	980057-E

Mode of operation

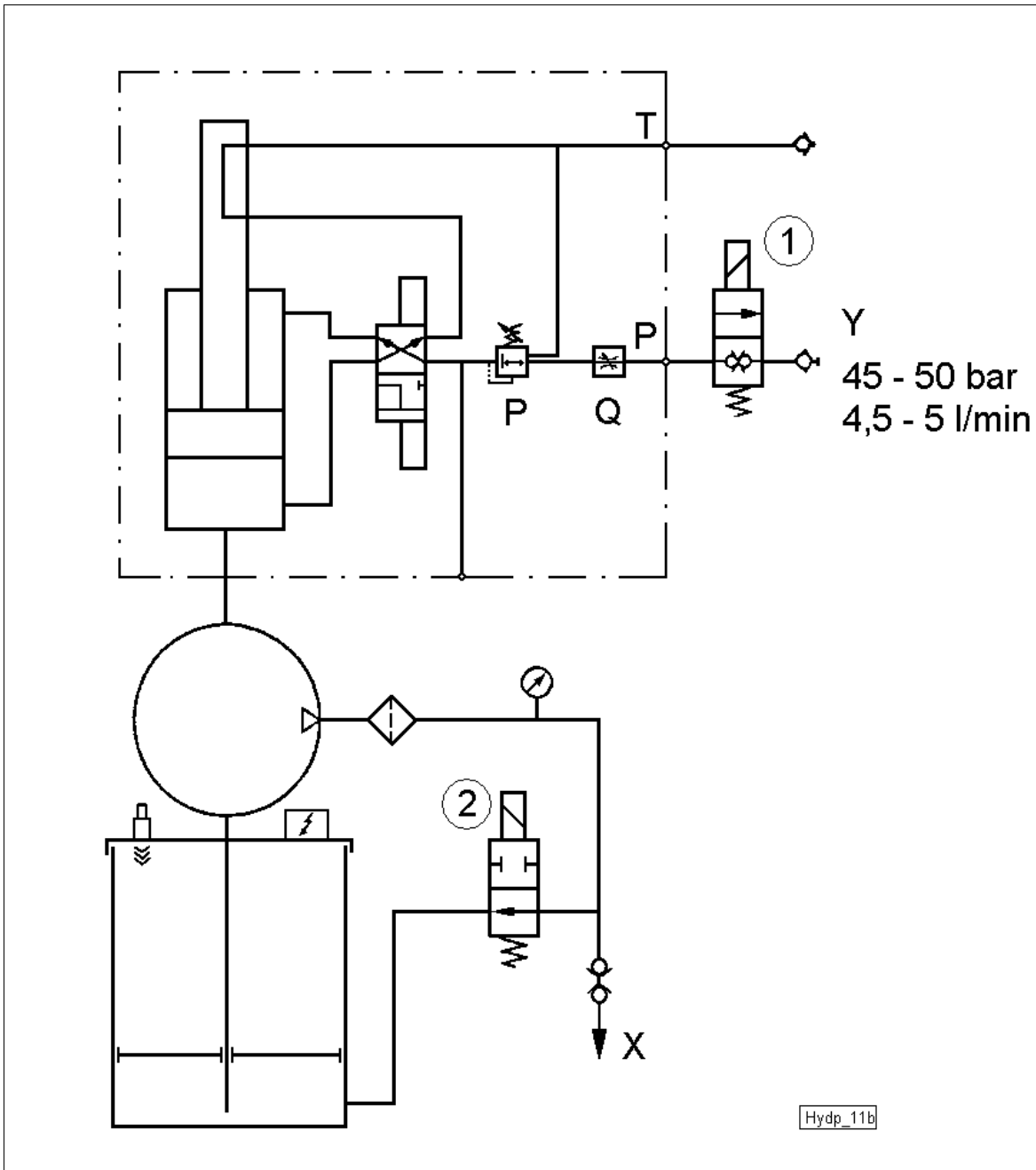

Fig. No. 2 Functional diagram of the hydraulic pump

The oscillating cylinder is a self-switching working cylinder with an automatic direction changeover unit. A connection block with flow regulating valve and pressure reducing valve is fitted at the cylinder head.

The cylinder starts when, after the 2/2-way solenoid valve ① has opened, pressure of the hydraulic system is applied on the connection P. The cylinder first retracts at the start, irrespective of the direction it had when it was switched off. Once the cylinder has reached its final position, it automatically reverses its travelling direction. If the

movement is stopped when the cylinder moves out, e.g. if the oil flow is stopped or if the backpressure is too high, the cylinder also retracts again. The cylinder actuates the flanged pump tube. Grease is fed into the centralized lubrication system via the pump tube and the connection "X".

The 2/2-way solenoid valve ② relieves the lubricant line to the reservoir after all injectors have discharged lubricant to the connected lubrication points.

Technical data

Pressure ratio (theoretical): 10 :1
Pressure ratio (practical): 6.55 :1
Lubricant output per double stroke: 30 cm³
Output pressure: max. 295 bar

Lubricant output at 4,5l/min, 45 bar oil pressure: 360 cm³/min
(corresponds to 12 double strokes/min)
Ambient temperature: -20 to +60° C
Sound pressure level: <70 dB(A)

Quantity of hydraulic oil: max. 10 l/min
Pressure of hydraulic oil: 45 - 50 bar
Oil viscosity: 22 mm²/s (at 40°C)
Filtration required: 10 µm

Electrical equipment

Low level indicator (sonar sensor) part no. 664-36973-1
2/2-way solenoid valve for grease, 24 VDC, G 1/2" type 2/2-400-VP1S-1/2-A24 part. no. 235-13174-1
2/2-way solenoid valve for hydraulic oil, 24 VDC G 3/8 part no. 235-13181-5

See the enclosed Data Sheets

Erection and installation

Erection of the pump

Requirements for the installation site:

- protected from dust and dirt
- safe from atmospheric influences
- free space for maintenance work
- even, stable and vibration-free installation site

Electric connection

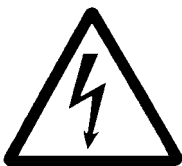

All electrical works should be carried out only by qualified personnel.

Carry out the electric connection in accordance with the terminal diagram.

Operating instruction

Start up

Connect only clean supply lines and supply hoses to the pump.

Before starting the pump, be sure that all connections (particularly the hydraulic connections) are tight.

Read and observe the recommendations of the manufacturer of the hydraulic fluid as regards compatibility. Use protective clothes and devices.

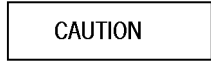

The pump may only be started if the lubricant container is full.

When refilling take care that no dirt or foreign bodies enter into the container.

The hydraulic oil for the drive must be free from condensate and impurities. Filtration required: 10µm.



The pressure regulator for the hydraulic oil is set at 45 bar. Do not change this setting.

All component parts of the lubrication system (tubes, hoses, tube fittings, etc.) must be designed for the highest system pressure.

Filling of the 200I-container:

Once the minimal grease level is reached in the reservoir, the ultrasonic sensor gives a signal to the electric control unit. The container has to be refilled immediately.



- **Stop refilling when grease is escaping from the overfilling safety valve ('X' in figure 1)**
- **The sealing of the follower plate could be damaged if the filling pressure is too high**
- **Do not close the opening of the overfilling safety valve**

Settings

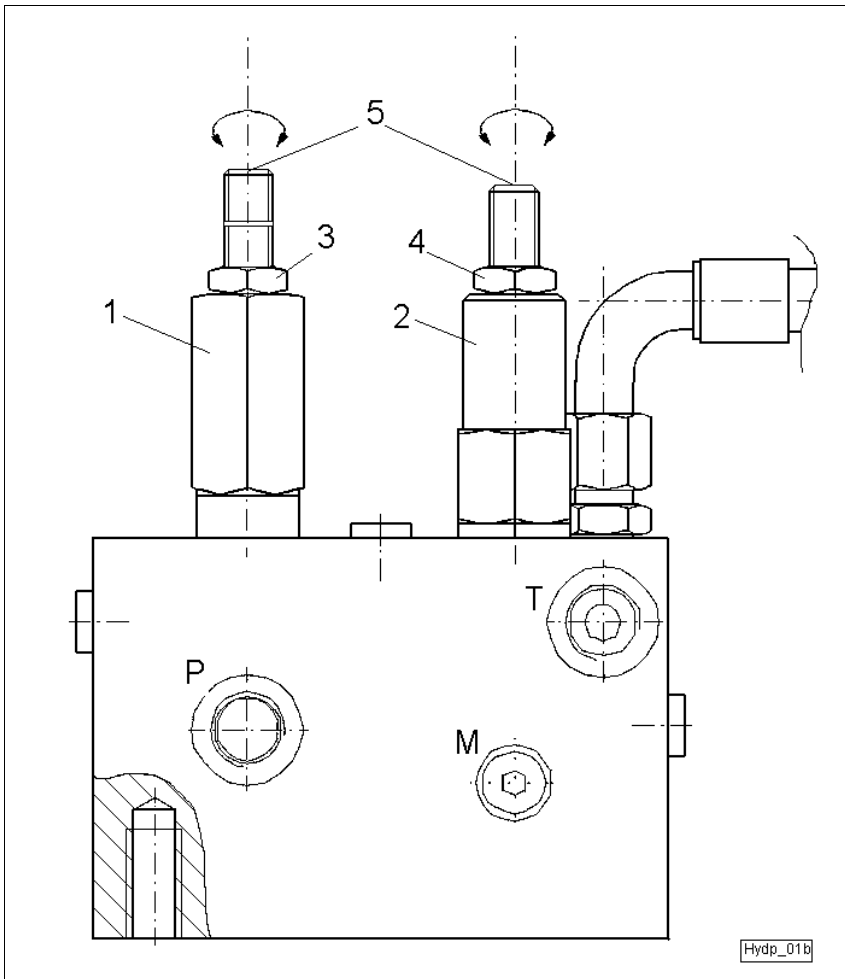

(Fig.3: Oscillating cylinder)

1. Flow regulating valve (item 1)

The travelling speed of the cylinder is determined by the supplied quantity of oil. The operating range of the flow regulating valve is between 2 l/min and 20 l/min. Turning the set screw (item 5) clockwise increases the oil quantity. Turning the set screw counter clockwise reduces the oil quantity. After completing the adjustment, tighten the set screw with the counter nut (item 3, SW 17).

2. Pressure reducing valve (item 2)

The max. inlet pressure is 200 bar. The pressure reducing valve allows the operating pressure to be set between 12 and 140 bar. Turning the set screw (item 5) clockwise increases the operating pressure. Turning the set screw counter clockwise reduces the operating pressure. After completing the adjustment, tighten the set screw with the counter nut (item 4, SW 19).

To control the set operating pressure, one can connect a measuring device to the connection M.

CAUTION

The operating pressure must be selected in such a way that the max. permissible supply pressure of the pump and the max. system pressure of the system are not exceeded.

Maintenance and repairs



- Do not disassemble the pump while the hydraulic cylinder, the pump tube and the supply system are under pressure.
- Do not rinse or clean the pump/pump tube with flammable fluids.
- Hands off the lower part (suction inlet) of the pump during starting, trial run and operation of the pump.

Before disassembling the pump, stop it and relieve the pressure from the drive (hydraulic cylinder), pump tube and supply system.

- Drain the supplied medium by opening an outlet valve (shut-off valve, gun) of the supply line and collect it into a basin.

Warning. The supplied medium is still under pressure. Once the line is pressureless and the medium no longer issues, close the shut-off valve located nearest to the supply line. Only then, carefully loosen the connection with the supply line at the outlet of the pump tube and unscrew the line (hose).

Maintenance, inspection and repair work may be carried out only by qualified personnel.

Troubleshooting

Fault: Pump does not deliver

- | | |
|---|---|
| <p>Cause:</p> <ul style="list-style-type: none"> • Hydraulic pressure supply insufficient • No input signal (voltage) at the solenoid valve ① see figure 2 | <p>Remedy:</p> <ul style="list-style-type: none"> • Check hydraulic pressure. Setting of pressure reducing valve ② (fig. 3) too low. Increase setting. • Check electric connections and solenoid valve |
|---|---|

Fault : No pressure build-up in the system

- | | |
|---|---|
| <p>Cause:</p> <ul style="list-style-type: none"> • Grease container empty • Air pockets in pump tube • Lubricant lines leaky • Inlet valve in pump tube damaged or worn • Precision piston (item 26, fig. 5) damaged or worn • The supplied medium cannot be sucked properly because it is too viscous and the stroke frequency is too high. | <p>Remedy:</p> <ul style="list-style-type: none"> • Refill grease container • Vent pump: Loosen knurled thumb screw (item 10, fig 5). As soon as the grease issues without air pockets, retighten screw. • Check the line system for loosened fittings, broken lines and detached hoses. Retighten the fittings, replace the defective tubing. Replace the hose or connect it anew. • Disassemble, check and replace it if necessary. • Disassemble, check and replace it if necessary. • Reduce the stroke frequency by throttling the output flow (pressure reducing valve ② ,fig. 3). |
|---|---|

Repair of the pump tube

The disassembly instructions are intended for specialists with a particular knowledge of hydraulics.

Do not modify the equipment! Use only original spare parts. Always use (replace) all parts/packings from the kits. See Spare parts list for kits and parts.

Tools required

DIA 2-1/8" (approx. 54 mm) strap wrench*

Retaining ring pliers (external)

Retaining ring pliers (internal)

Pliers

19/32", 5/8", 11/16", 7/8", 13/16", 1-3/8" and 2-1/4" hex. wrenches, 7/8" dynamometric key.

We recommend 2-1/8" segment strap wrench, robust steel design, LINCOLN no. 236829; LINCOLN no. 236832 handle necessary.

Disassembly procedure

Note: the following indications in bold brackets

() refer to the item numbers of the spare parts drawing and spare parts list.

1. Unscrew adapter tube **(28)** from pump tube **(18)**.
2. Pull on adapter tube **(28)** until connection between bushing & plunger **(26)** and bushing & plunger (part of **31**) is exposed and can be disconnected. Unhook shovel piston rod and remove complete with lower segment **(27-37)**.
3. Unscrew priming tube **(37)** from adapter tube **(28)**.
4. Remove lower check assembly (items **29** through **36**) from adapter tube **(28)**.
5. Remove cotter pin **(32)** from bushing & plunger (part of **31**).
6. Remove priming shovel nut **(36)** from bushing & plunger **(31)**.

7. Remove retaining ring **(29)** and guide washer **(30)** from bushing & plunger **(31)**.
8. Remove O-ring **(27)** from pump tube **(18)**.
9. Remove bolt connector **(1)** from plunger **(3)**.
10. Grip bushing & plunger **(26)** and by hand remove plunger **(3)**, connecting rod **(21)**, adapter **(22)** and bushing & plunger from pump tube **(18)**.
11. Remove pump tube **(18)** from outlet housing **(9)**.
12. Remove O-ring **(17)** from outlet housing **(9)**.
13. Remove gland nut **(4)** from outlet housing **(9)**.
14. Remove adapter **(11)** and priming plug **(10)** from outlet housing **(9)**.
15. Remove outlet body **(16)** from outlet housing **(9)**.
16. Remove ball **(14)**, check seat **(13)** and gaskets **(12)** from outlet housing **(9)**.
17. Remove retaining ring **(8)**, packing washer **(7)** and U-cup packing **(6)** from gland nut **(4)**.
18. Remove bushing & plunger **(26)** from Adapter **(22)**.
19. Remove ball **(23)** from adapter **(22)**.
20. Remove pin **(25)** and ball **(24)** from bushing & plunger **(26)**.
21. Remove cotter pins **(20)** from connecting rod **(21)**.
22. Remove adapter **(22)** and plunger **(3)** from connecting rod **(21)**.

Repairs

1. Check bushing & plunger **(26)**; replace them, if they are worn or damaged.
2. Check valve & bushing and plunger of set **(31)**; replace **(31)** completely if they are worn or damaged.
3. Check plunger **(3)**; replace it if worn or damaged.
4. Check the remaining parts and replace them if necessary.
5. Replace all gaskets.

Re-assembly To re-assemble pump, reverse disassembly procedure. Refer to illustration for torque specification of screw at item 1!

Spare Parts for Hydraulic Pump Part-No. 509-32178-1

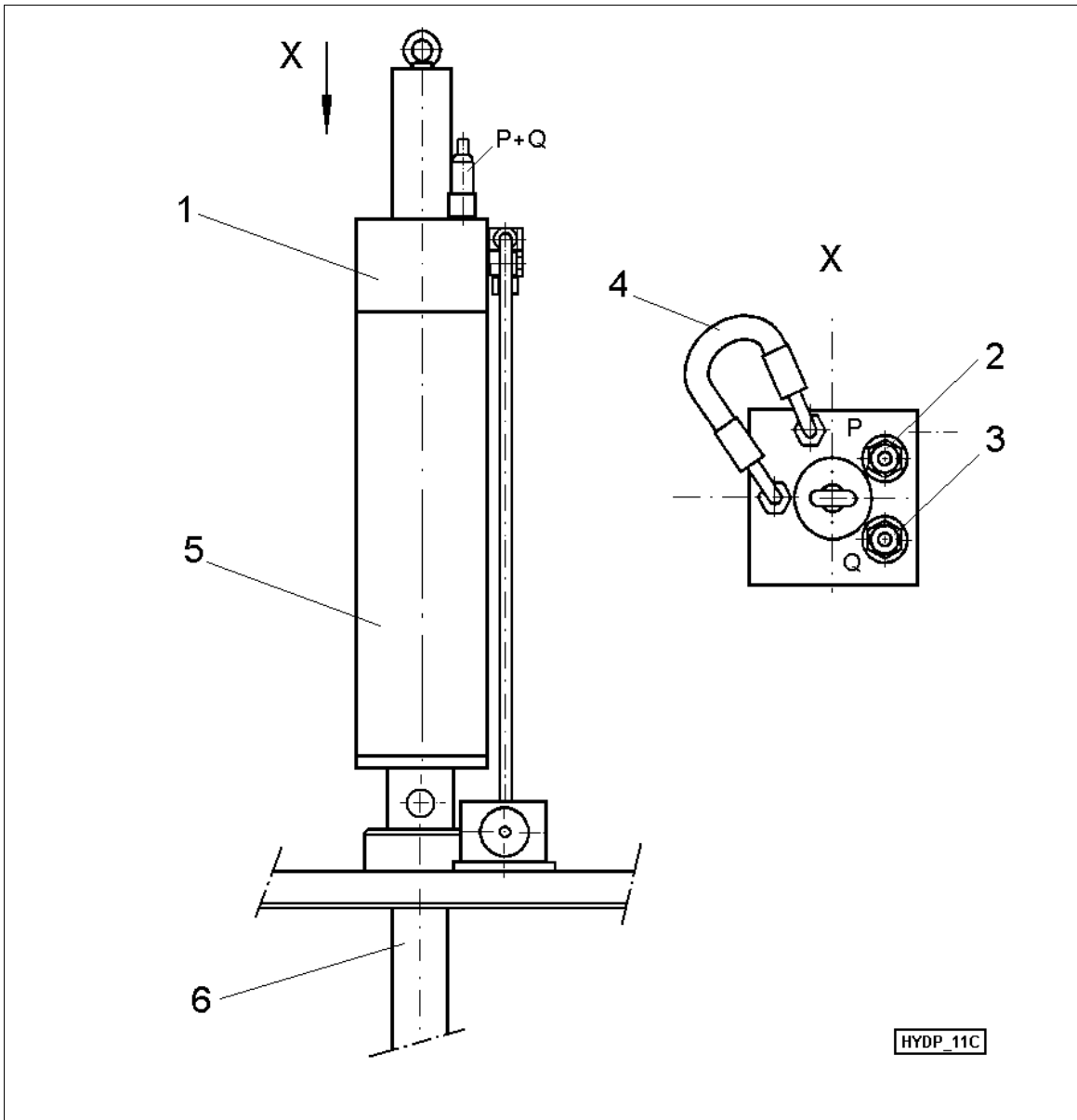

(Fig. 4: Spare parts of the hydraulic pump)

Item	Description	Qty.	Part number
1	OSCILLATING CYLINDER ASSY. WITH CONTROL BLOCK	1	235-13183-1
2	PRESSURE REDUCING VALVE 14-83 BAR	1	235-13179-2
3	FLOW REGULATING VALVE 2-20 L/MIN	1	235-13179-3
4	HOSE LINE DN 10 x 500	1	235-13183-3
	SET OF SEALING RINGS FOR OSCILLATING CYLINDER		235-13183-2
5	COVER	1	409-24712-1
6	PUMP TUBE	1	084997
	(single parts: see pages 10 + 11)		

How to replace the sealing kit on the oscillating cylinder

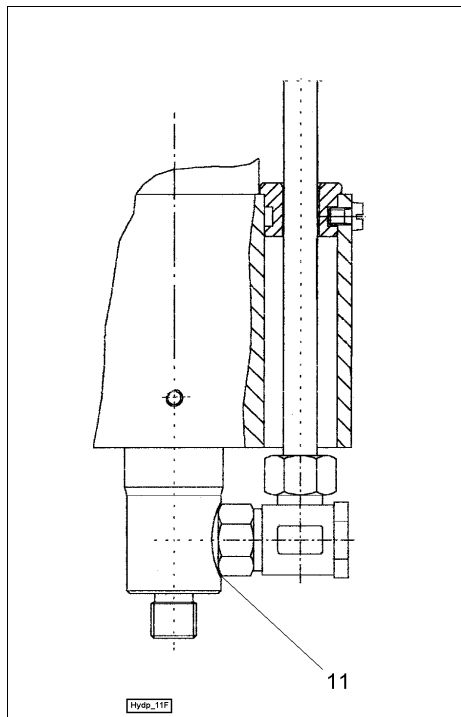
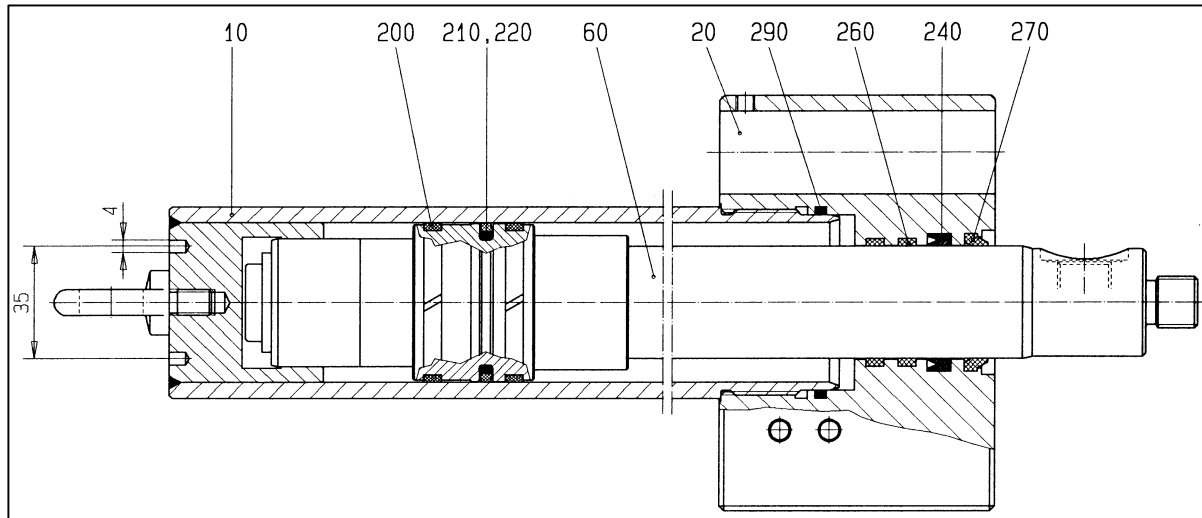

**sealing kit for oscillating cylinder
part no. 235-13183-2 consisting of:**

Item	Qty.	Description
200	1	Piston guidance ring
210	1	Turcon Glyd-Ring
220	1	O-Ring 37,69 x 3,53
240	1	U-cup sealing 35 x 43 x 7
260	1	Rod guidance ring
270	1	Scraper 35 x 43 x 7
290	1	O-Ring 55,0 x 3,0
11	1	Usit-Ring 18 x 24,7 x 7,5 (sealing elbow joint - piston rod)

Disassembly

- Loosen the housing of the cylinder **pos. 10** with a pin-type face spanner A35, DIN 3116 and remove it from the cylinder head **pos. 20** (do not clamp the cylinder tube).
- Remove piston unit **pos. 60** from the cylinder tube **pos. 10** and the cylinder head **pos. 20** and dismantle the sealings.



When dismantling the sealings, the lining groove must not be damaged.

Installation



When mounting the sealings, the sealing and the lining groove must not be damaged.

Cylinder Head

- Before the installation slightly grease over the sealings.
- Mount the guide rings **pos. 260** and O-ring **pos. 290**.
- Press together the rod sealing **pos. 240** and the scraper **pos. 270** and insert it into the grooves.

The profiled side of the rod sealing is the pressure side.

Piston Unit

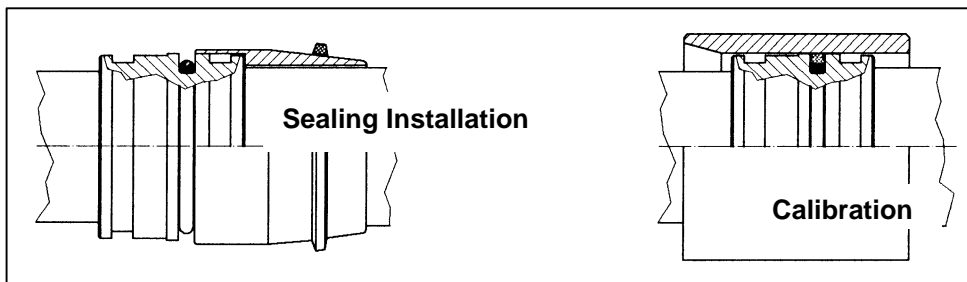

- Slip mounting sleeve onto the piston unit **pos. 60**.
- First push the O-ring **pos. 220** over the mounting sleeve into the groove and then the Glyd ring **pos. 210**. Heat the Glyd ring in oil, water or by means of a hot air ventilator up to a temperature of 80°C – 100°C in order to facilitate installation.
- Calibrate the mounted sealing with the calibrating sleeve.
- Insert guide rings **pos. 200** into the groove.

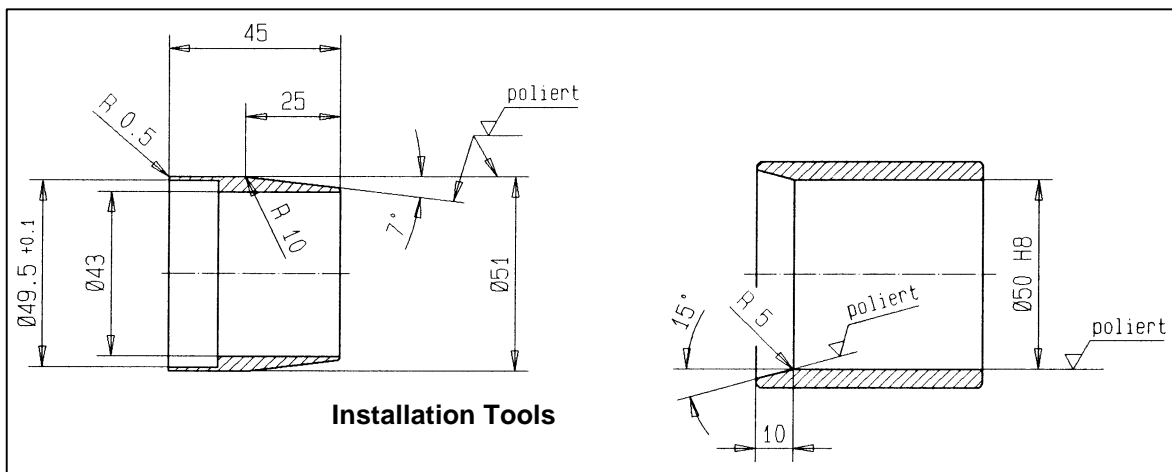

The mounting and calibrating sleeve is available as special accessory.

Cylinder

- Rub the piston unit **pos. 60** and the thread on the cylinder tube **pos. 10** with oil.
- Plug components together carefully and without force.
- Screw together the cylinder head **pos. 20** and the cylinder tube **pos. 10** up to the stop and firmly tighten with the pin-type face spanner A35, DIN 3116 (strike with a hammer).

Spare parts drawing – Pump tube 84997

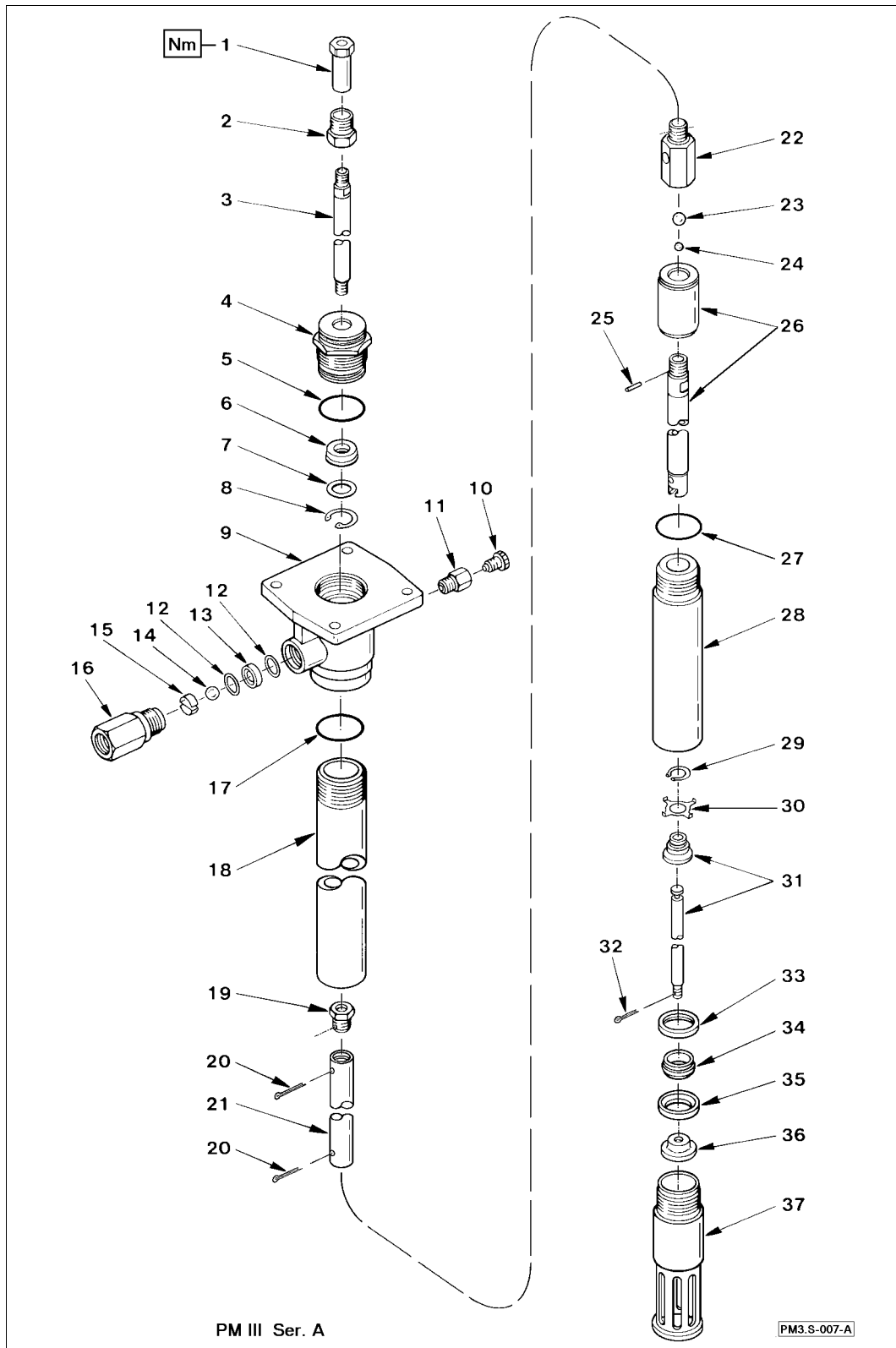

Caution
Tighten screw (item 1) with a torque of 88 Nm

Spare parts list for pump tube 84997

Item	Description	Qty.	Part number
1	BOLT CONNECTOR	1	242 363
2	COUPLING NUT	1	237 051
3	PLUNGER ROD	1	242 932
4	GLAND NUT	1	242 936
5	O-RING, polyurethane	1	*
6	U-CUP, polyurethane	1	*
7	PACKING WASHER	1	*
8	RETAINING RING	1	*
9	OUTLET HOUSING	1	242 216
10	PRIMING PLUG	1	16 382
11	ADAPTER	1	16 381
12	GASKET, copper	2	*
13	OUTLET CHECK	1	11 948
14	BALL	1	66 285
15	BALL STOP	1	57 036
16	OUTLET BODY	1	12 017
17	O-RING, nitrile	1	*
18	PUMP TUBE	1	242 373
19	ADAPTER	1	13 242
20	COTTER PIN	2	*
21	CONNECTING ROD	1	242 372
22	ADAPTER	1	91 916
23	BALL	1	66 285
24	BALL	1	66 007
25	PIN	1	13 240
26	BUSHING & PLUNGER	1	242 549
27	O-RING, nitrile	1	*
28	ADAPTER TUBE	1	242 374
29	RETAINING RING	1	*
30	GUIDE WASHER	1	*
31	BUSHING & PLUNGER	1	242 546
32	COTTER PIN	1	*
33	RETAINER	1	13 227
34	CHECK	1	13 229
35	CHECK SEAT	1	13 228
36	PRIMING SHOVEL NUT	1	13 235
37	PRIMING TUBE	1	242 375

Note: * These parts are contained in repair kit no. 86 234; items not available individually.