

Extension and connecting tubes for control valve Griff E

The control valve Griff E with screwed on hydraulic coupler is supplied as standard product.
 the hydraulic coupler at the connecting tube with coupling nut M 16 x 1.25 is also deliverable as spare Part-No. 251-14043-2.



This hydraulic coupler is suitable for all hydraulic lubrication fittings acc. to DIN 71412



Type „A“
 straight hydraulic lubrication fitting



Type „A“
 AM 10 x 1
 AR 1/8“

Connecting tubes

For all domed-head lubrication fittings acc. to DIN 3402

Example:

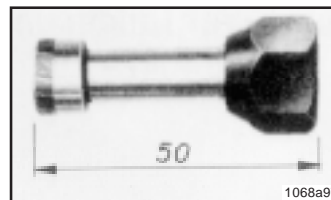

Connecting tube domed-head coupler
 No. 251-14043-3

For all flush lubrication fittings acc. to DIN 3405

Example:



Type „B“
 45° angle hydraulic lubrication fitting



Type „A“
 AM 10 x 1
 AM 8 x 1
 AM 6



Type „C“
 90° angle hydraulic lubrication fitting



Connecting tube with flush coupler
 No. 251-14043-4

If other lubrication fittings are available, the connecting tube with the hydraulic coupler is to be unscrewed and replaced by the following connecting tubes with coupling M 16 x 1.25.

Extension and connecting tubes for control valve Griff E

For all button head lubrication fitting acc. to DIN 3404



Form A
 AM 10 x 1, AR 1/4" Lubrication fitting DIA 16, with over flats 17
 AM 16 x 1,5, AR 3/8" Lubrication fitting DIA 22, with over flats 22

Extension tubes

For lubrication fittings which cannot be reached by means of the connecting tubes, the following extension tubes, each having an inch thread of M 16 x 1.25 and a coupling nut M 16 x 1.25, can be supplied:

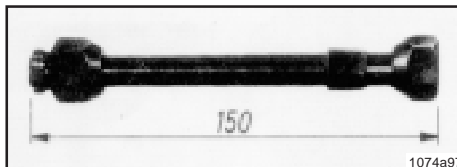

Straight extension tube Part-No.
 251-14042-8

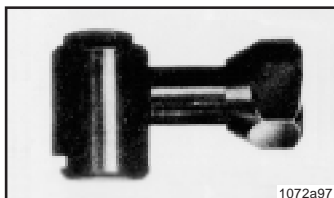

Connecting tube with push coupler
 Lubrication fitting DIA 16 Part-No.
 251-14043-6
 Lubrication fitting DIA 22 Part-No.
 251-14043-8



Angle extension tube Part-No.
 251-14042-9

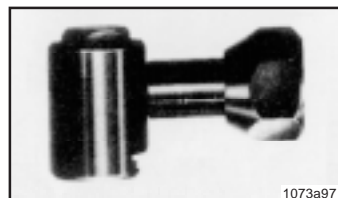

Connecting tube with pull coupler
 Lubrication fitting DIA 16 Part-No.
 251-14043-6
 Lubrication fitting DIA 22 Part-No.
 251-14043-8

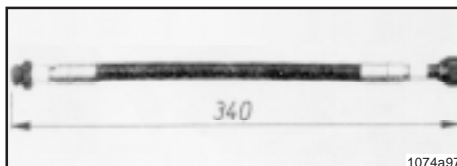

Extension hose Part-No.
 251-14043-1

For domed-head lubrication fittings and hydraulic lubrication fittings that are difficult to reach, an adapter can be supplied:

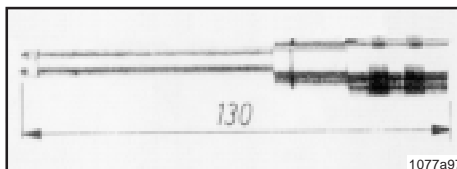

Part-No.
 251-14043-9

At the end of a thin extension tube the adapter is fitted with a coupler, the adapter is connected with the hydraulic coupler by means of a locking sleeve.

Universal swivel with hose connection

Part-No. 626-27204-1

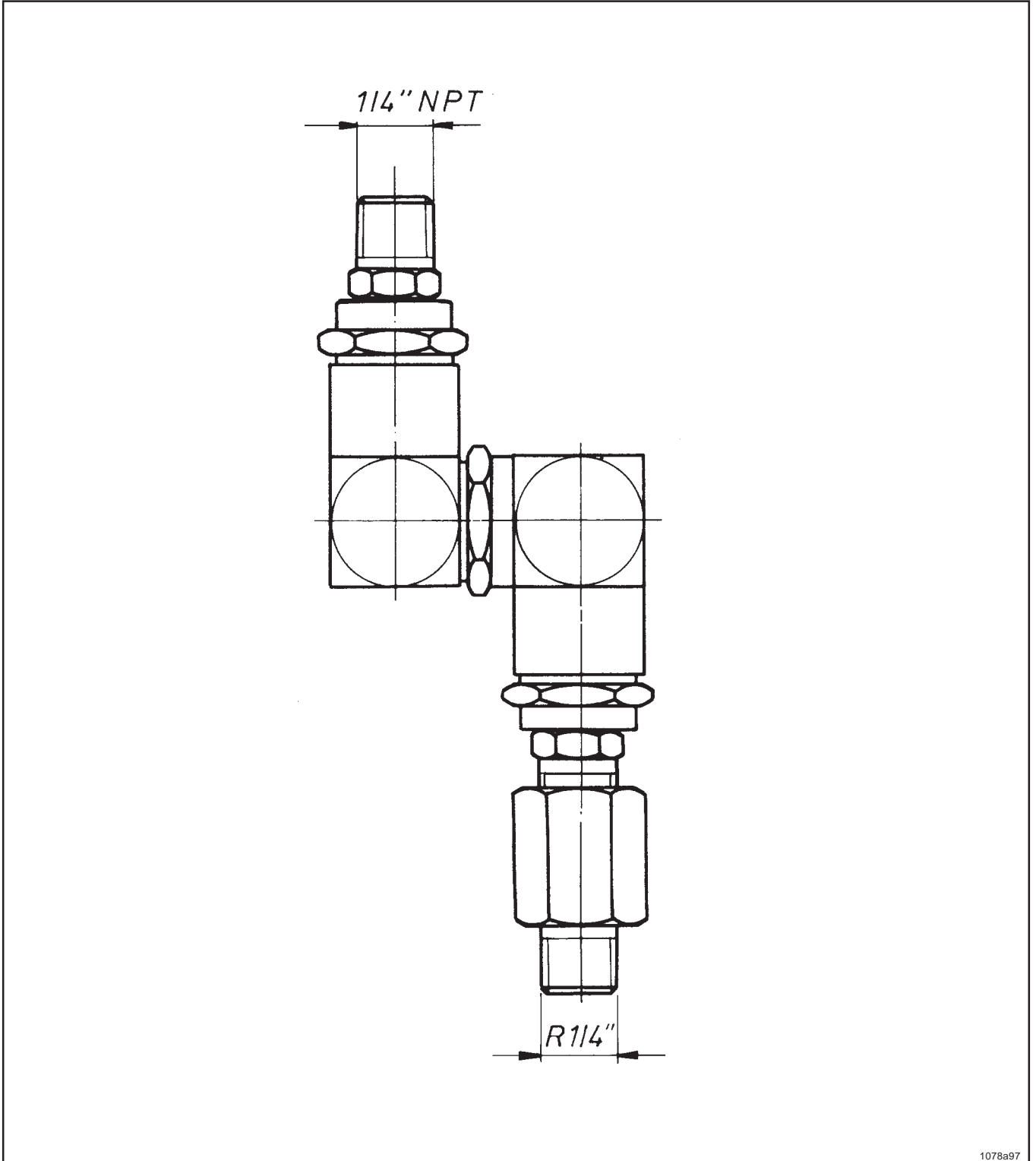

Subject to modifications

Grease gun for use with Lincoln Control Valve Griff E

Part-No. 626-27172-1

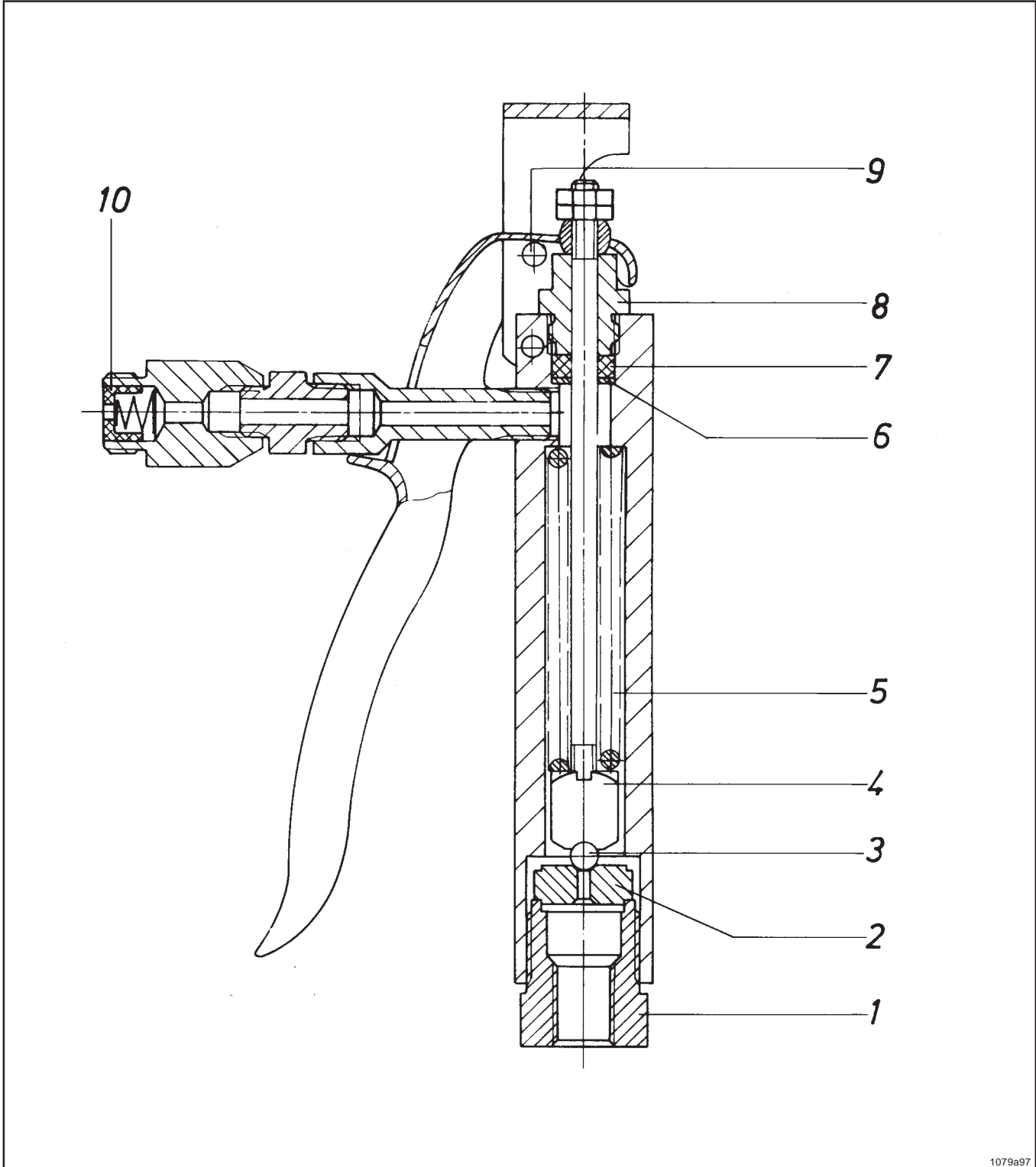

1079a97

Subject to modifications

Grease gun for use with Lincoln Control Valve Griff E

Part-No. 626-27172-1

| Item | Designation | Part-No. |
|------|--------------------------------|-------------|
| 1 | coupling nut | LC 12829 |
| 2 | check seat | LC 11364 |
| 3 | steel ball | LC 66255 |
| 4 | ball retainer | LC 11363 |
| 5 | compression spring | LC 55029 |
| 6 | washer | LC 48218 |
| 7 | packing | LC 35007 |
| 8 | packing gland | LC 12826 |
| 9 | toggle pivot screw | LC 11837 |
| | hexagon nut | LC 51043 |
| 10 | axial cup seal D80 with spring | 251-14045-5 |