

COBRA 501

Lubrication device for moving lubrication points

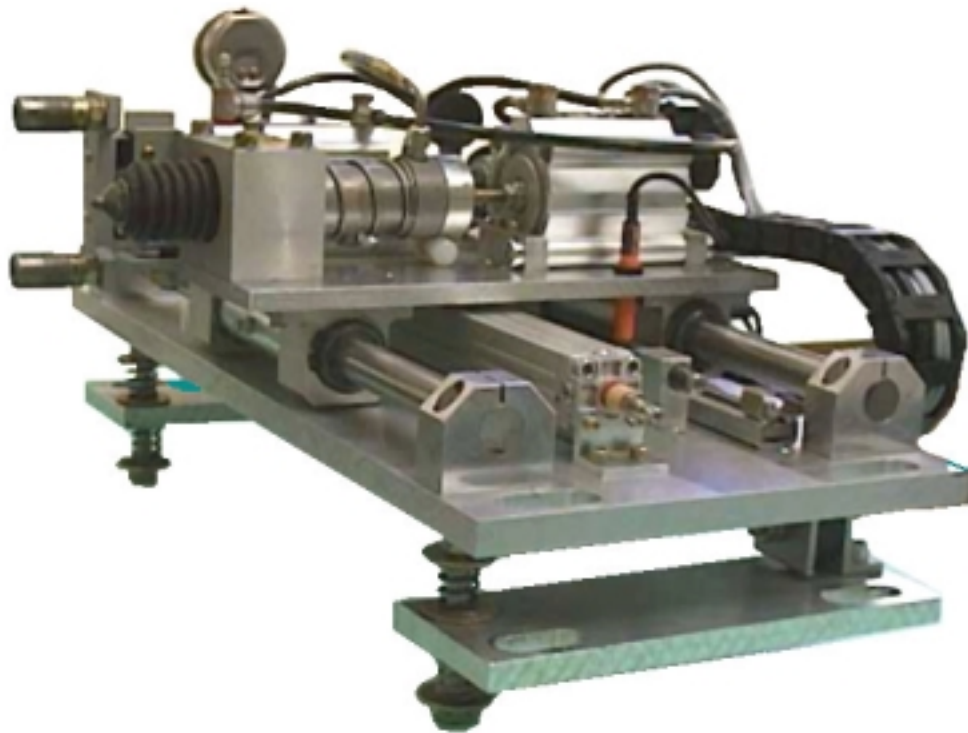

4311a01

1. Preface

- The Owner's Manual is intended to familiarize the user with the pump/lubrication system and to enable him to use it correctly.
- The Owner's Manual contains important information for the safe, correct and economic operation of the pump/lubrication system. Its observance will help avoid hazards, reduce repair costs and downtime and increase the reliability and prolong the service life of the pump/lubrication system.
- The Owner's Manual must be supplemented by the respective national regulations concerning the prevention of accidents and protection of the environment. The Owner's Manual must always be available on the site where the pump/lubrication system is in operation.
- Persons charged with work with/at the pump/lubrication system who do not have a good command of the English language must be informed by the user of the pump/lubrication system on the contents of the Owner's Manual, particularly the safety instructions, before they carry out the work.
- The Owner's Manual must be read and used by all persons who are charged with working with the pump/lubrication system, e.g.
 - **operation, including adjustment, troubleshooting during operation, elimination of production waste, maintenance, disposal of process materials**
 - **maintenance (inspection, repairs) and/or transport.**

Table of Contents

Chapter		Page
1	Preface	2
2	Safety instructions	3
3	Description	5
3.1	Designation	5
3.2	Appropriate use	5
3.3	Mode of operation	5
3.4	Dimensions	9
3.5	Safety functions	10
3.6	Technical data	11
4	Erection and installation	11
4.1	Mechanical installation	11
4.2	Electrical installation	13
5	Operating instructions	13
5.1	Setting	14
5.1.	Setting of the pick-up arm	14
5.1.2	Setting of the distance between the pick-up arm and the lubrication head	14
5.2	Starting up	14
5.2.1	Recommendations for the starting up	15
5.3	Shutdown	15
5.4	Maintenance	15
5.5	Troubleshooting	16
6	Spare parts drawing and spare parts list	18

2. Safety instructions

- The Owner's Manual includes general instructions which must be followed when a pump/lubrication system is installed, operated or serviced. Therefore, it is absolutely necessary for the fitter and specialist/user to read the Owner's Manual before a unit is installed and put into operation. The Owner's Manual must always be available on the site where the machine/system is installed.
- All general safety instructions contained in this main chapter on safety must be observed as well as special safety instructions given in other main chapters.

Hazard marking in the Owner's Manual

- The notes referring to safety contained in the Owner's Manual whose failure to observe them may result in personal injury are marked by the general hazard symbol below.



Hazard marking acc. to DIN 4844-W9

The following symbol warns of an electrical current.

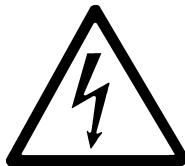

Safety marking acc. to DIN 4844-W8

- If ignoring the safety note might result in machine damages and malfunction, the word

Caution

is added.

- Warnings fixed directly to the machine must always be observed and must be kept in completely legible condition.

Staff qualification and training

- The staff responsible for operation, maintenance, inspection and installation must be suitably qualified for this work.
- The user must accurately regulate the field of responsibility and supervision of the personnel.
- If the personnel is not in command of the necessary expertise, they must receive the appropriate training and instruction. If necessary, this can be done by the manufacturer/supplier upon request of the machine user.
- Furthermore, the user must ensure that the contents of the Owner's Manual are fully understood by the personnel.

Hazards resulting from failure to observe the safety instructions

- Failure to read the safety warnings may endanger persons as well as the environment and equipment.
- Failure to observe the safety notes may result in the loss of all claims for damage.
- As an example, in the following we list some dangers which may result from failure to observe the warnings:

- failure of machine/system to fulfill important functions
- failure of specified methods for maintenance and repair
- personal injury due to electrical, mechanical and chemical influences
- danger to the environment due to leakage of harmful substances

Safety-conscious working

- Observe the safety instructions given in the Owner's Manual, the prevailing national regulations for the prevention of accidents and any working, shop and accident prevention of the user.

Safety instructions for the user/operator

- If warm or cold machine parts present hazards, the customer must guard them against accidental contact.
- Do not remove guards from moving parts while the machine is in operation.
- Dispose of leakages of harmful materials so as to jeopardize neither persons nor the environment.
- The requirements of the law must be satisfied.
- Exclude danger caused by electrical current (for details refer to the applicable specifications of VDE and the local power supply companies).

Safety instructions for maintenance, inspection and installation work

- The user must make sure that all maintenance, inspection and installation work is executed by authorized and qualified experts who have thoroughly read the Owner's Manual.
- On no account may work be done on the machine while the machine is in operation and only at standstill. Follow all instruction for shutting down the machine as described in the Owner's Manual.
- Decontaminate pumps and pump units delivering harmful substances.
- Replace all safety and protection devices immediately after completion of the cleaning procedure.
- Dispose of substances harmful to the environment in accordance with the applicable official regulations.
- Before putting the pump/ pump unit into operation, ensure that all points given in the chapter "Starting up" are fulfilled.

Unauthorized modification and spare parts production

- Alteration and modifications of the machine are only allowed on approval by the manufacturer. Original spare parts and accessories authorized by the manufacturer ensure operation. If other parts are used, the manufacturer may be released from its liability for the resulting consequences.

Inadmissible operating modes

- The operational safety of the supplied product is only ensured if the product is operated according to chapter 3.2. The maximum ratings listed in the Technical Data must never be exceeded.
- The operation of the Cobra is admissible only in the prescribed moving direction of the chain/ belt.
- Commissioning of the product (pump/pump unit) within the European Union is forbidden until it has been stated that the machine on which the product is to be installed meets the requirements of the EU directives.

3. Description

3.1 Designation

- This Owner's Manual refers only to the lubrication devices:
- COBRA 501-L-S01-SF-400-M01-000+SPL
Item N°. 680-40781-2 and
- COBRA 501-R-S01-SF-400-M01-000+SPL
Item N°. 680-40780-2

3.2 Appropriate Use

- The lubricating device COBRA 501 is designed exclusively for the lubrication of moving lubrication points on roller or chain conveyors. The COBRA 501 should be supplied with lubricant only via central lubrication pumps with pressure reducing valves.
- Any other use is not in conformity with the appropriate use and may result in the loss of all warranty claims or claims for damage. The same applies for failure to observe the technical data.

3.3 Mode of Operation

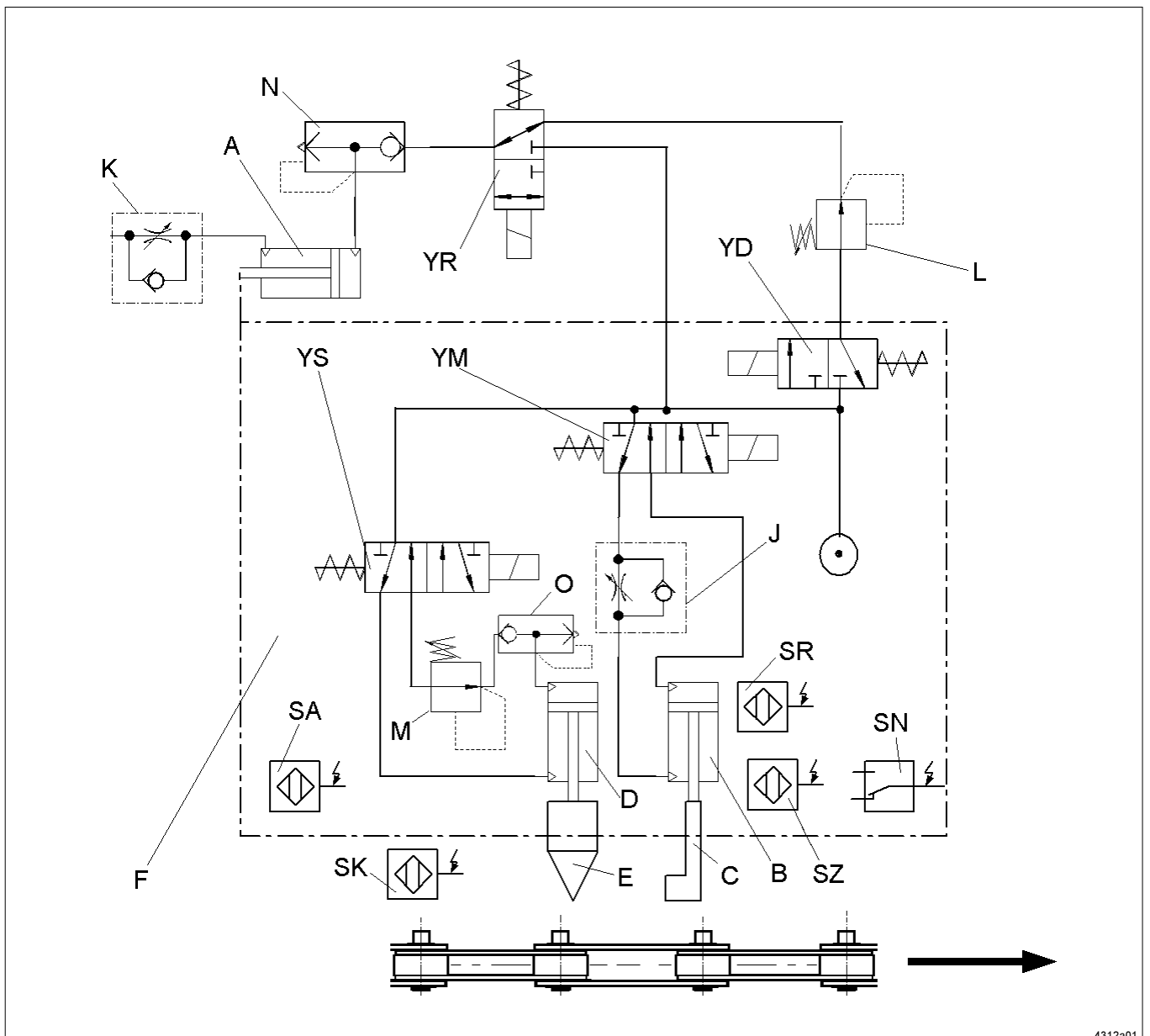

Fig. 1: Functional Diagram

4312a01

Subject to modifications

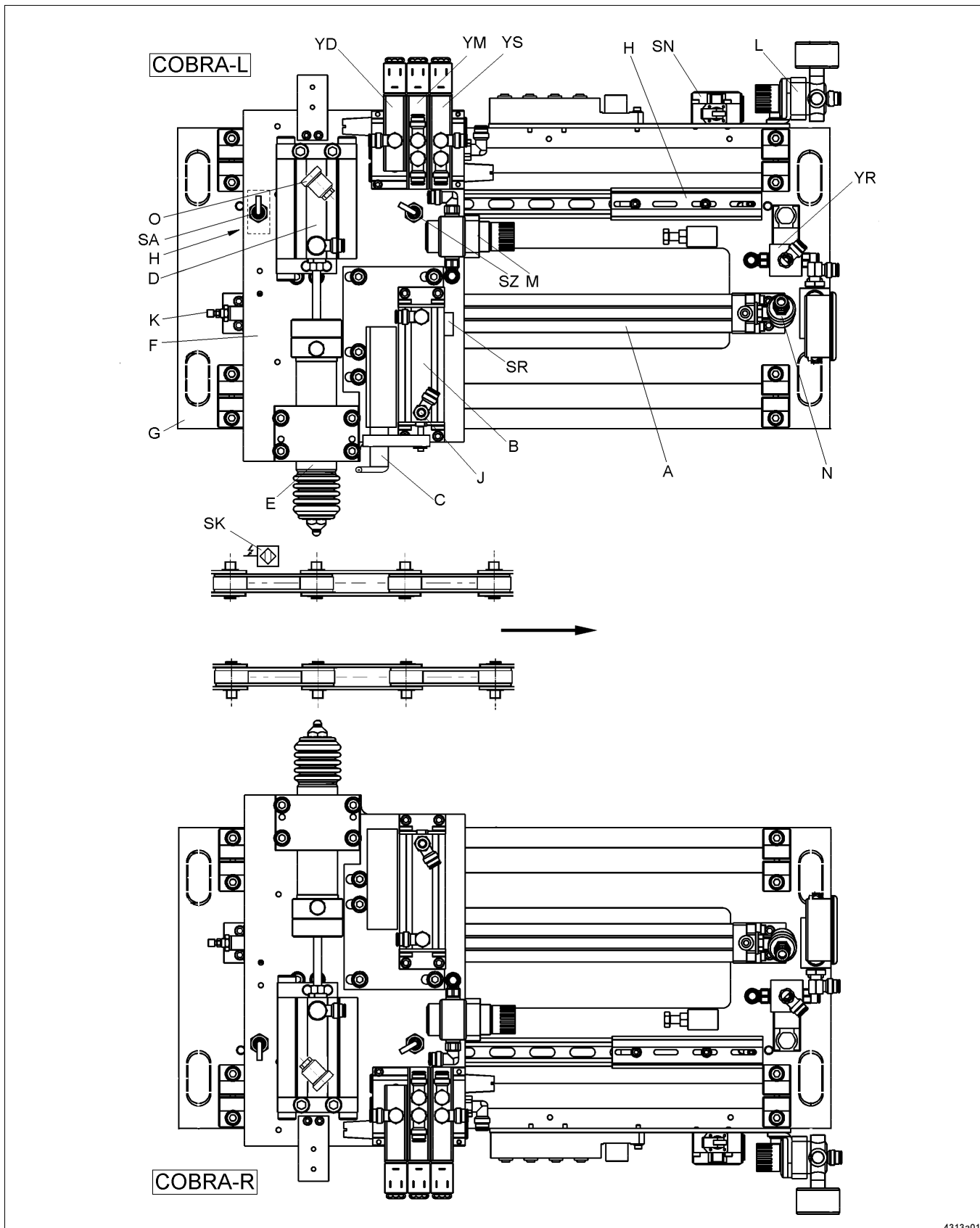

Fig. 2 - Operating mode of the COBRA 501 (COBRA-L = left Cobra, COBRA-R = right Cobra)

4313a01

Subject to modifications

NOTE: Valve or sensor designations for left-hand COBRA in initial position.

Preconditions:

- The belt moves in the prescribed direction.
- The COBRA 501 must be in initial position, i.e. the proximity switches SA and SR are dampened (switched on) .
- A working cycle of the COBRA is initiated by the proximity switch SK.

A)The proximity switch SK inductively detects the position of the chain and, at the same time, connects the YM 5/2-way solenoid valve. The air pressure acts on the pick-up arm cylinder (B) and the pick-up arm (C) moves forward.

Note: The sequence of the lubrication cycles (every roller or every second roller, etc.) depends on the number of rollers and on the speed of the chain or roller conveyor or on the distance between the rollers.

B)The roller to be lubricated detects the pick-up arm (C) and at the same time moves the COBRA 501 exactly in parallel to the roller.

Note: The pick-up arm and the lubrication head are firmly installed on a carriage (F) which is placed on a frame (H) in such a way as to be easily movable.

Cylinder A is pressurized with a dampening pressure via pressure regulator L and valve YD do make sure that the carriage does not move with the roller jerkingly but controlled. The dampening pressure is factory-set and should not be modified.

C) During the movement the dampening component leaves the zone of the SA proximity switch. The SA proximity switch goes into resting position and at the same time activates the YS 5/2-way solenoid valve. The air pressure acts on the lubrication head cylinder (D) in such a way that the lubrication head (E) moves onto the lubrication point of the roller. At the same time, the solenoid valve YD goes into resting position; the dampening pressure becomes ineffective.

- The correct operation of the lubrication head can be checked by:
 - Observing the pressure gauge in the lubricant and air connection block (visible pressure drop when the lubrication head is pressed onto the lubrication point);
 - Observing the front bellows at the lubrication head: Shortening the front bellows (bellows between the mouth piece and the lubricant input at the lubrication head) as a function of the metering distance sleeve at

max. stroke.....approx. 17 mm

or

reduced stroke.....approx. 10 to 13 mm for the lubricant outputs of approx. ...0.15, 0.3, 0.45 and 0.6 cm³/stroke

D) When the lubrication head (D) is pressed onto the lubrication hole, a piston supplies the lubricant to the lubrication point from a pre-filled metering chamber.

E)The lubricant supply is finished by the dampening of the SZ proximity switch. The SZ proximity switch connects the YS 5/2-way solenoid valve to the initial position, the cylinder of the lubrication head is retracted. After expiration of a delay time the YM 5/2-way solenoid valve is connected to the initial position and the cylinder of the pick-up arm (B) is retracted.

F)The piston in the cylinder of the pick-up arm switches the SR proximity switch. The SR proximity switch activates the valve YR. The retracting cylinder moves the carriage F to the initial position. The SA proximity switch is dampened again.

Note: The SN position switch has only a safety function. If the "pick-up arm leaves the chain" phase does not take place because of a fault, the carriage activates the SN position switch just before the mechanical final position is reached. All valves are de-energized. The pick-up arm leaves the chain and the carriage remains in its position.

When a fault is acknowledged, the carriage has to be moved back to the initial position manually.

The following speeds respectively pressures are factory-set and shall only be readjusted for maintenance or repair works:

- Extending speed of the pick-up arm (C) adjustable on the throttle check valve J (see step A).
- Retracting speed of the carriage F adjustable on the throttle check valve K (see step F).
- Dampening pressure (see notes below step B) adjustable on the regulator L (factory-set to approx. 0.5 bar).
- Pressure for the lubrication head can be adjusted on regulator M (factory-set from 3.5 bar to 4 bar).

Flow Chart

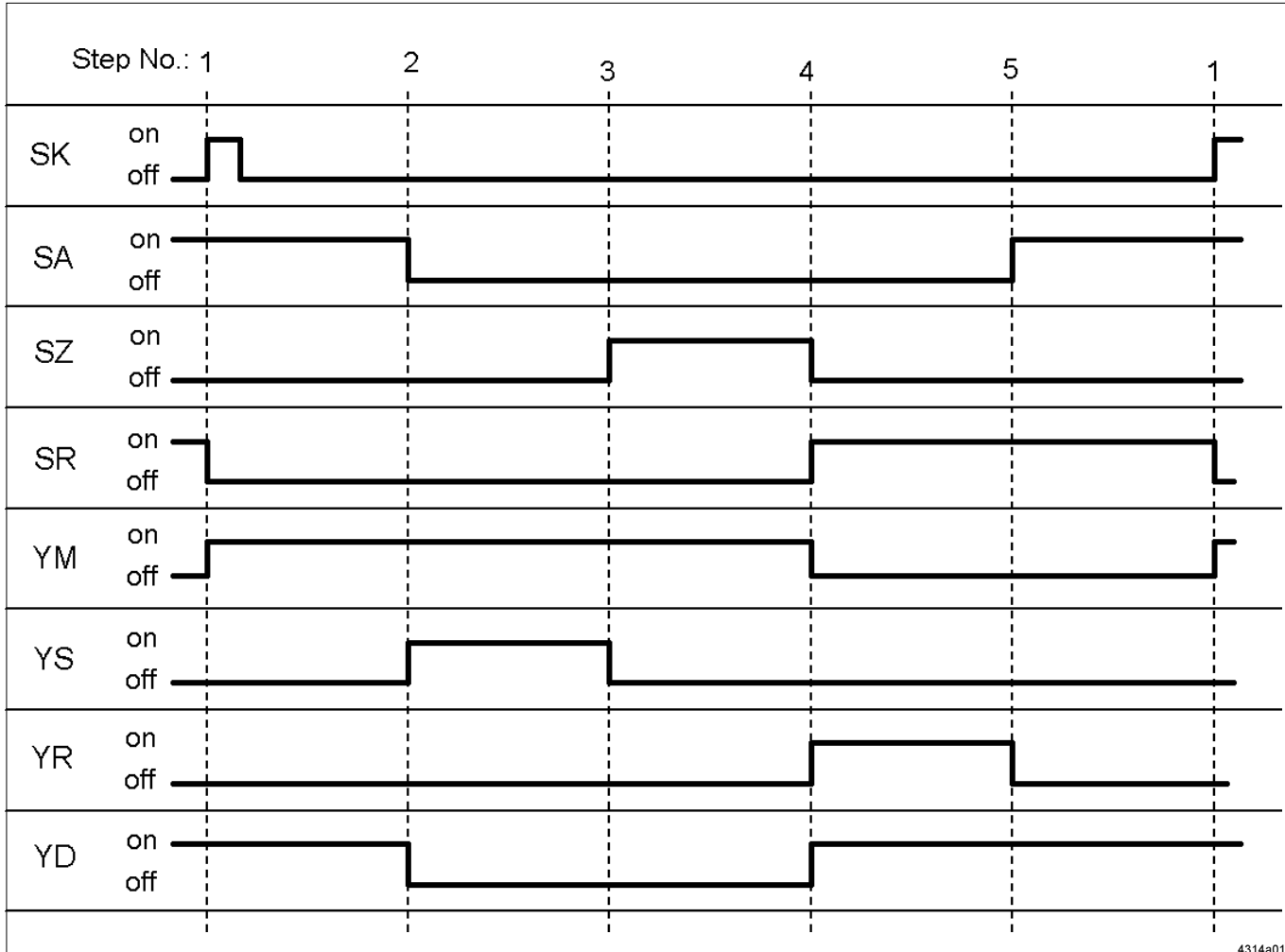

4314a01

Fig. 3: Flow Chart

Step 1:
The chain switches SK

Step 2:
The roller touches the pick-up arm and moves the carriage

Step 3:
The carriage moves towards a component that switches SZ

Step 4:
After a programmed time (e.g. 0.2 sec) which is started in step 3, the solenoid valve YM is switched off.

Step 5:
The carriage returns to its initial position. SA is switched.

- A: Retracting cylinder
- B: Cylinder of pick-up arm
- C: Pick-up arm
- D: Cylinder of lubrication head
- E: Lubrication head
- S.: Switches
- Y.: Solenoid valves

3.4 Dimensions

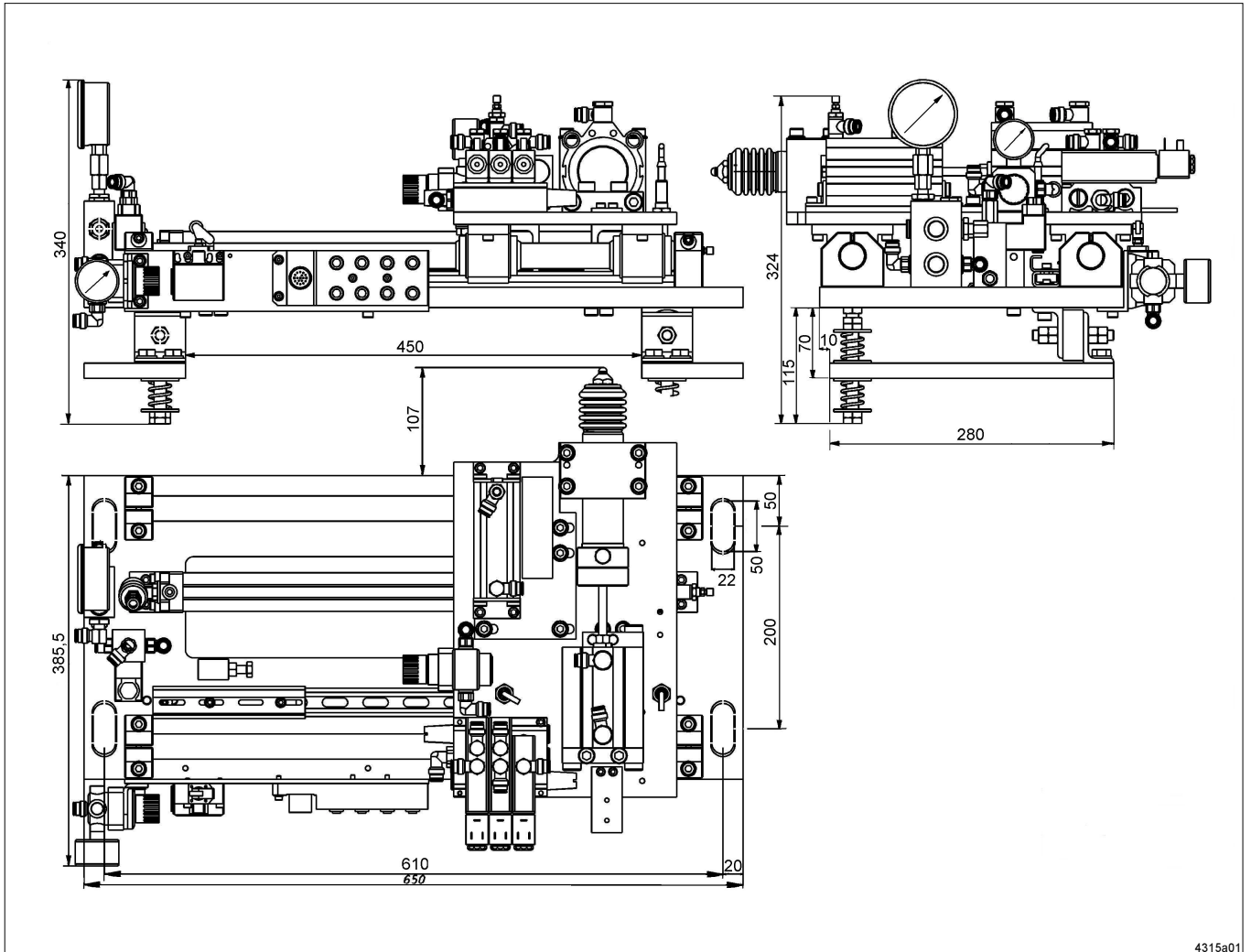

4315a01

Fig. 4: Dimensions

3.5 Safety Functions

Faults in the current supply:

- Owing to its specific control concept the COBRA 501 is immediately separated from the chain or roller conveyor in the case of such a fault and remains in the safe resting position until the fault has been remedied. After this, the COBRA is started again.

Swing-out mechanism of the pick-up arm:

- The swing-out mechanism stops major damages, e.g.
 - in cases where the pick-up arm (fig. 6, item 6) is still engaged whereas the carriage (fig. 2, item F) already bangs against the stop at the frame,
 - in cases where the chain speed is too high and/or the system control is too low or when the SN position switch fails to operate.



Pick-up arm and lubrication head move back into the initial position automatically.
Warning: Danger of bruise in case of an interruption of the power supply.

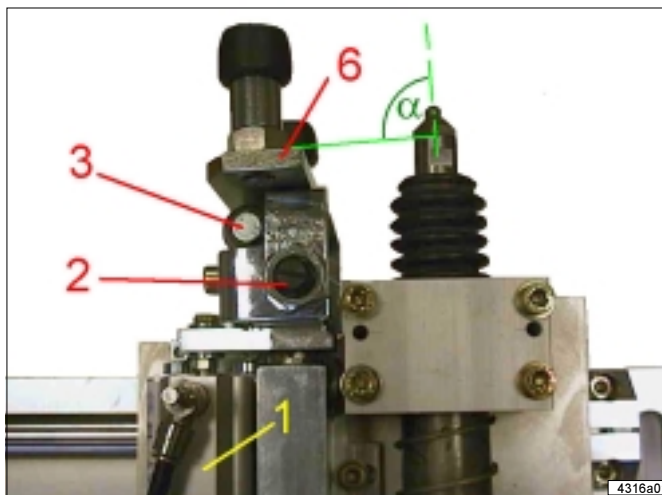

Fig. 5: Swing-out mechanism

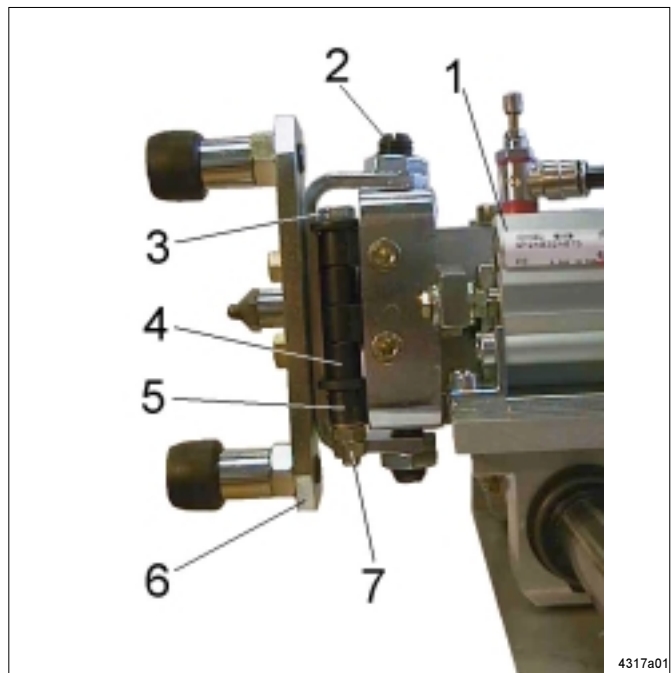

Fig. 6: Swing-out mechanism

Description of the swing-out mechanism:

The roller side bar (6) is attached to a hinge (4). In case of a troublefree operation, the hinge (6) forms a 90° angle α to the lubrication head center line. In this position, the hinge is maintained by a spring washer kit (5).

In the above mentioned malfunction, the hinge overcomes the tension force of the spring washer kit and swings out of the engaging area of the chain via the screw (3) as the spin axis.

Setting of the swing-out mechanism:

After remedying the fault:

- Loosen nuts (7) and swing the pick-up arm into a 90° position to the lubrication head center line. Overcome the retention force of the ball thrust pieces (2) by light beats with a plastic hammer (the ball thrust pieces serve as a fixing aid for setting the 90° angle).
- Tighten nut (7) with 34 Nm and fix by a lock nut.

3.6 Technical Data

Air connection: G 3/8
 Lubricant connection: G 3/8
 Inlet air pressure: 5 - 6 bar
 Inlet lubricant pressure:
 40 - 70 bar (grease), 20 - 40 bar (oil)
 Lubricant output: max. 1.0 cm³/stroke
 Factory setting with distance sleeve ~1 cm³/stroke
 Stroke of pick-up arm: adjustable between 30-75mm
 (smaller strokes by using distance washers)
 Max. stroke of lubrication head without lubricant supply,
 i.e. lubrication head does not move to the lubrication
 point: 50 mm
 At max. lubricant supply 30 mm
 Supplied media: Grease NLGI 2 or oil
 Operating temperature: -10° to +50° C
 Max. lubrication frequency: 1/s
 Max. carriage stroke: 250 mm (until switching SN)
 Chain speed: 0.4 m/s
 Sound pressure level: < 70 dB/A
 Weight: approx. 30 kg

Electrical Data:

Supply voltage: 24 V DC, residual ripple <5%
 Power consumption: 25 W without additional equipment
 Protection: IP 65

Notice regarding the lubrication frequency:

$$\text{Lubrication frequency} = \frac{\text{chain speed}}{\text{chain pitch}}$$

(Chain pitch means the distance between the rollers to be lubricated)

4. Erection and installation



The erection and installation should be made only when the roller or chain conveyor is not in operation.

4.1 Mechanical installation



Attention: A supporting framework with **sufficient resistance** must be installed for mounting 4 threaded spindles M 20 (holes acc. to dimensional drawing) at the roller or chain conveyor to be lubricated.



Attention: Protect against access by unauthorized persons. Danger of crushing while the COBRA is in operation.

Determination of the installation height:

- The COBRA 501 lubrication head center line must be parallel to and at the same height as the center line of the rollers to be lubricated during the whole carriage runway.
- Compensate any fluctuation in height by setting the M 20 threaded spindles at the fixing device.
- The maximum fluctuation in height of the lubrication nipple is ± 10 mm from the center of the lubrication head.

Note:

The fluctuation in height of the lubrication nipple results from the **fluctuation in height of the roller + eccentricity of the lubrication nipple on the roller + eccentricity of the roller.**

If the fluctuation in height of the lubrication nipple is greater, the chain must be guided accordingly in the COBRA engaging area.

Subject to modifications

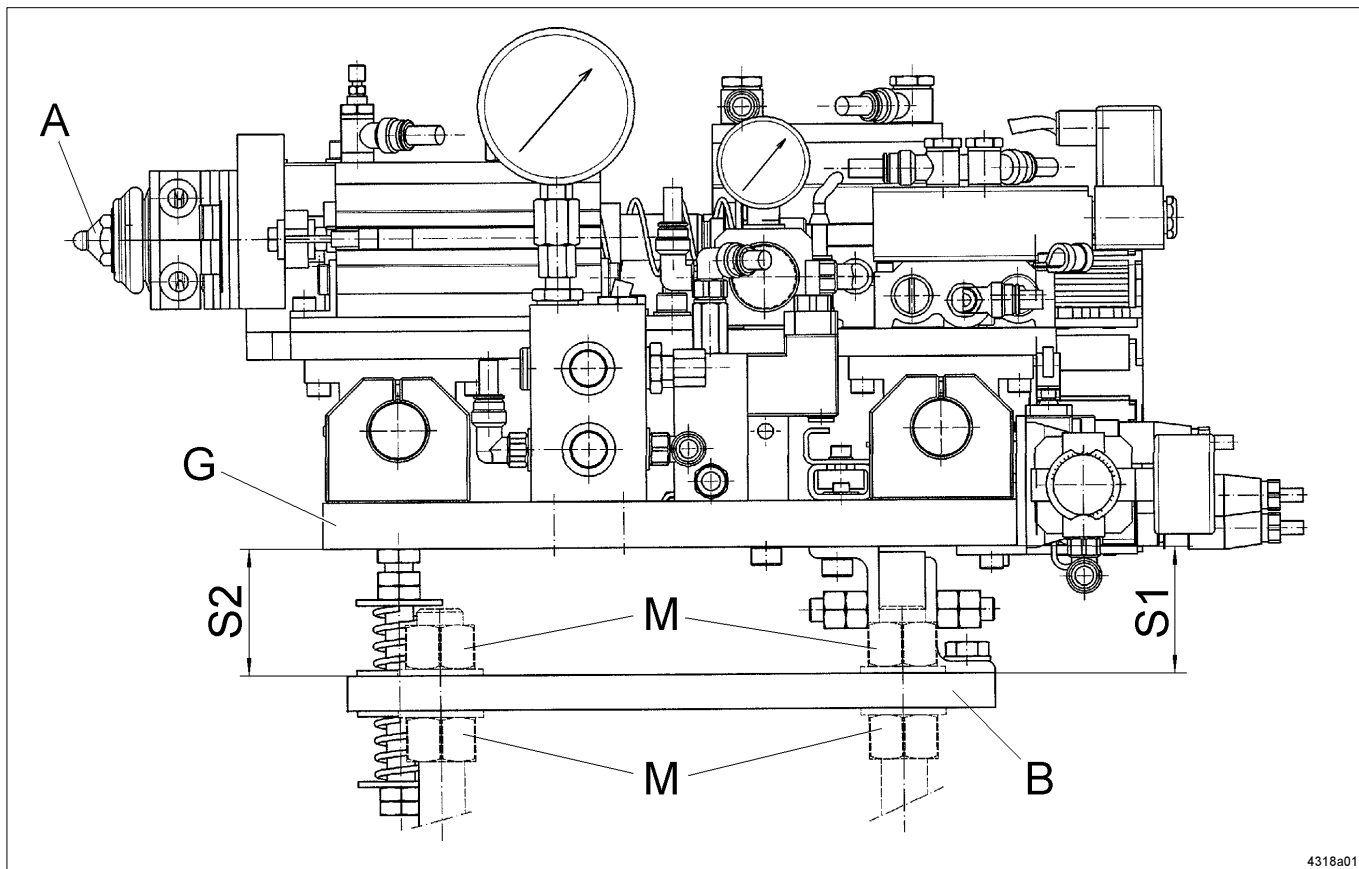

Fig. 7: Setting of height

Setting of the height position

Set the height position by means of the 8 nuts M in such way that:

1. the mouth piece A is on the same height as the lubrication nipple during the whole carriage runway.
2. the fixing plates B are aligned parallelly to the center line of the rollers to be lubricated; i.e. normally align the fixing plates B horizontally by means of a water level.

Regarding chains respectively belts with only small fluctuations in height of the lubrication nipples (less than 1.5mm), the COBRA can be directly attached to the 4 long holes of the base plate G by means of 4 threaded rods and 8 nuts M 20.

The fixing plates B and the corresponding fixing and resiliency material can be omitted.

The setting of the height position is to be effected as described.

Note:

The measures S1 and S2 are the same and factory-set; Control and adjustment only after maintenance or repair works.



The fixing nuts have to be secured against unintentional working loose.

Determination of the horizontal installation position:

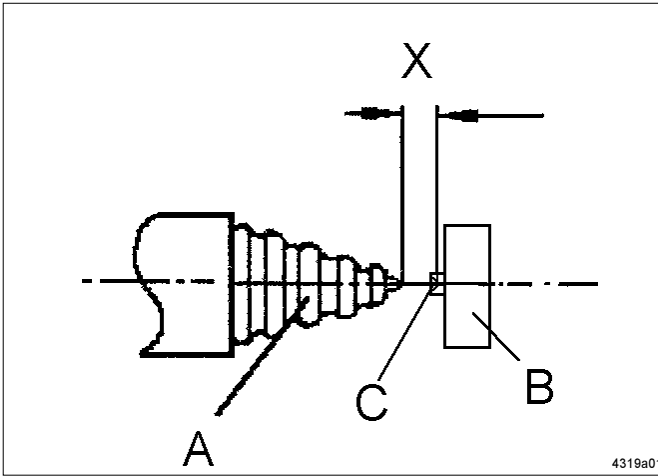

Fig. 8:- Horizontal installation position

- | | |
|------------------------|----------------------------|
| A - Lubrication head | X - Normal distance: 20 mm |
| B - Roller | Minimum distance: 10 mm |
| C - Lubrication nipple | Maximum distance: 30 mm |

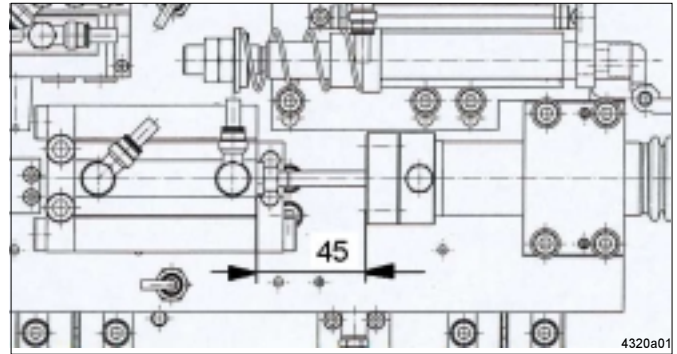
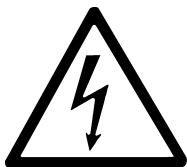

Fig. 9: Horizontal installation position

- Before setting the measure X, check the distance 45 between the lubrication head and the cylinder of the lubrication head.
- Determine horizontal installation position acc. to Fig. 5.
- The COBRA can be positioned via the long holes in the attaching plates.
- Maximum horizontal roller movement: ± 5 mm
- If the horizontal roller movements are longer than ± 5 mm, the rollers must be guided laterally by an auxiliary construction at the roller or chain conveyor.

Note: The minimum and maximum distances must also be adhered to by taking into consideration the horizontal roller movement.

4.2 Electrical installation



- The electrical installation must be made according to the description of the whole system and wiring diagram.

All electrical work may be executed only by qualified personnel.

5. Operating instruction



Observe the following for all work at the COBRA 501:

- Danger of crush due to possible carriage movement within the frame (see Fig. 1, items F - H).
- Danger of impact when the pick-up arm and the lubrication head (see Fig. 1, items D and C) extend and retract, particularly when the chain sensors SK as well as the sensors SR and SZ are not activated correctly.

Subject to modifications

5.1 Settings

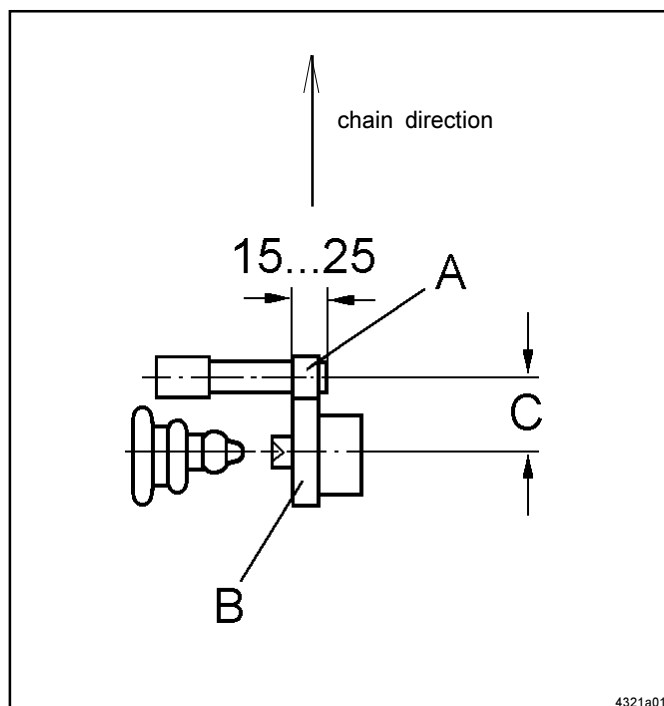

Fig. 10:- Setting of the pick-up arm

5.1.1 Settings of the pick-up arm (see Fig. 6 and 7)

Important: The pick-up arm must be set when the COBRA 501 is in a correct horizontal position (see Fig. 5: normal distance 20mm with retracted cylinders of the pick-up arm and lubrication head).

- Engaging depth of the pick-up element A, fig. 6, when the cylinder of the pick-up arm is extended: 15 to 25 mm.
- Set the engaging depth by adjusting the lock nut F, fig. 7, on the guiding rod. This will limit the stroke of the pick-up arm (maximum stroke of the pick-up arm: 75 mm).

A – Pick-up element
B – Sensing disk (roller)
C – Distance: pick-up arm – lubrication head

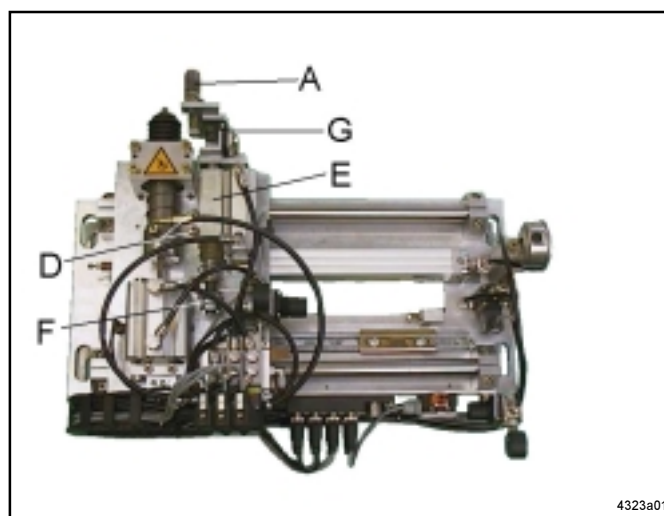

Fig. 11:- Setting of the distance: pick-up arm - lubrication head

5.1.2 Setting the distance pick-up arm – lubrication head (see fig. 6, item C)

- Carry out the setting with the COBRA in the state as shown on Fig. 6:
- The cylinder of the pick-up arm is extended; the pick-up element (A) is in contact with the sensor disk (B).
- Unscrew the 4 screws (D), Fig. 7, (M 8 x 18)
- Slide the bearing of pick-up arm (E) until the lubrication head and the lubrication nipple are aligned in one axis with the pick-up element being in contact.

Note: Pick-up arm guiding rod and longitudinal axis of pick-up arm cylinder must be parallel to the longitudinal axis of the lubrication head

* Tighten 4 screws D, Fig. 7 (M 8 x 18).

A – Pick-up element
D – Fastening screws M 8 x 18 (4 pieces)
E – Bearing of pick-up arm
F – Lock nut
G – Pick-up arm

5.2 Starting up

- Check the following system values:
 - COBRA inlet air pressure : 5 to 6 bar
 - COBRA inlet lubricant pressure : 40 to 70 bar in the case of grease, 20 to 40 bar in the case of oil
- Start operation of the COBRA in accordance with the description of the whole system.
- Check the lubricant supply: close the shut-off valve before the lubricant inlet of the COBRA;
- With the first lubrication cycle the pressure at the measuring device indicating the pressure supplied to the COBRA must fall by approx. 20 bar (grease) and to 0 – 10 bar (oil) after the shut-off valve is closed.

- If necessary: check the distance between the nipple and the lubrication head in accordance with Fig. 5.
- Check the state of the lubrication nipples.

5.2.1 Recommendations for the starting up



Fig. 12: Manual activation of the valves

Make use of the manual operation of the valves YM, YS and YD in order to control the settings (see chapter 4.1 and 5.1) **(only in case of a standstill of the chain)**

Verify the height position:

Manually move the carriage in such way that the center axis of the lubrication head points to the lubrication nipple on the chain.

Switch YS valve with screw driver on the manual operation (see arrow for sense of rotation on the manual operation). The COBRA mouth piece must hit into the center of the nipple. If necessary, correct by readjusting the nuts M.

Verifying the distance pick-up arm - lubrication head:

Manually move the carriage so far that (seen in chain direction) the lubrication head center line is positioned in front of a lubrication nipple. Switch Y11 via manual operation and press carriage against the roller to be lubricated with a manual force of approximately 100-250 N. Maintain carriage pressed against the roller and switch YS via the manual operation:

COBRA mouthpiece must hit the center of the chain lubrication nipple. If necessary, correct distance lubrication head - pick-up arm according to chapter 5.1.2.

5.3 Shut down

* Shut down the COBRA in accordance with the description of the whole system

5.4 Maintenance



Make sure to disconnect the COBRA from the power supply and lubricant supply before starting any repair and maintenance work.

- Protect the COBRA against coarse dirt and falling objects.
- Clean the guides once a month and lightly oil them (oil viscosity cl. 68)
- Use solvents on hydrocarbon basis (e.g. petroleum). Do not use trichlorethylene or benzene.

Attention: Risk of injury if the solvents are not handled expertly. Solvents must not come in contact with the eyes or skin lesions. The solvents must not be handled with open fire or light. Ensure adequate ventilation.

5.5 Troubleshooting

Fault: Pick-up arm does not extend (see figure 2, item C)	
• Cause	• Remedy:
<ul style="list-style-type: none"> • Proximity switch SK is not activated (see figure 2) • Carriage F and/or pick-up arm cylinder not in initial position resp. not recognized by sensors SA and/or SR. • YM valve is not activated (see fig. 2) • Fault in the compressed air supply system. 	<ul style="list-style-type: none"> * Check electrical connections and operation of the SK proximity switch. If necessary correct position of the SK proximity switch in such way that it is reliably dampened by the rollers; thereby make use of the LED on the switch. * Bring carriage and pick-up arm cylinder into initial position and/or check function of sensors by means of the LED. If necessary correct the position of the sensors. * Check electrical connections and operation of YM valve (the switching phase of this valve is indicated by LED). * Check compressed air lines. * Check the necessary inlet air pressure (see chapter 3.6, p = 5 - 6 bar)
• Fault: Pick-up arm (see fig. 2, item C) extends too slowly	
• Cause	• Remedy:
<ul style="list-style-type: none"> • Throttle check valve J is closed too much. 	<ul style="list-style-type: none"> * Open throttle check valve J somewhat more.
• Fault: Pick-up arm (see fig. 2, item C) extends too late	
• Cause	• Remedy:
<ul style="list-style-type: none"> • SK proximity switch is dampened too late. 	<ul style="list-style-type: none"> * Slide the SK proximity switch against the chain moving direction so that the next roller is sensed earlier.
• Fault: Pick-up arm (see fig. 2, item C) does not extend far enough or extends too far	
• Cause	• Remedy:
<ul style="list-style-type: none"> • The distance between the COBRA and the roller/chain conveyor is not correct. • Stroke of pick-up arm not set correctly. 	<ul style="list-style-type: none"> * Check horizontal position of the COBRA in accordance with 4.1, fig. 8 and 9, and correct it if necessary. * Check the setting of the pick-up arm in accordance with chapter 5.1, fig. 10 and 11, and correct it if necessary.
• Fault: Lubrication head (see fig. 2, item E) does not extend	
• Cause	• Remedy:
<ul style="list-style-type: none"> • YS valve (see fig. 2) is not activated. • Fault in the compressed air supply. 	<ul style="list-style-type: none"> * Check the electrical connections and operation of the YS valve (switching phase of valve indicated by LED) * Check the compressed air lines. * Check the necessary inlet air pressure required (see chapter 3.5 : p = 5 – 6 bar).
• Fault: Lubrication head (fig. 2, item E) does not extend far enough	
• Cause	• Remedy:
<ul style="list-style-type: none"> • The distance between the COBRA and the roller/chain conveyor is not correct. 	<ul style="list-style-type: none"> * Check horizontal position of the COBRA in accordance with chapter 4.1, fig. 5, and correct it if necessary.
• Fault: Lubrication head (see fig. 2, item E) comes down on the roller besides the lubrication nipple	
• Cause	• Remedy:
<ul style="list-style-type: none"> • Distance between the pick-up arm and the lubrication head is not correct (see fig. 2, items C and E). 	<ul style="list-style-type: none"> * Check distance between pick-up arm and lubrication head acc. to chapter 5.1.2, fig. 11 and correct it if necessary.

<ul style="list-style-type: none"> • Fault: No or insufficient lubricant supply with correct position of the lubrication head on the lubrication nipple 	
<ul style="list-style-type: none"> • Cause 	<ul style="list-style-type: none"> • Remedy
<ul style="list-style-type: none"> • Faulty lubricant supply, e.g. supply pump defective or too little lubricant in the reservoir, leakage in the lubricant line. • Inlet air pressure too low for the cylinder of the lubrication head. 	<ul style="list-style-type: none"> * Check the inlet lubricant pressure (see 5.2). Check the supply pump and the lubricant lines. * Check the air supply system of the cylinder of the lubrication head for leakage. * Check the COBRA supply air pressure (see chapter 3.5, 5 – 6 bar). * Check settings on the regulator M: pmin=3 bar (oil), 4 bar (grease)
<ul style="list-style-type: none"> • Fault: Pick-up arm (fig. 2, item C) does not move to initial position <i>Note: In such a case the pick-up arm will be put out of operation by its rated break point in order to avoid major damage. After remedying the fault, repair the pick-up arm (see 3.5, fig. 5 + 6).</i> 	
<ul style="list-style-type: none"> • Cause 	<ul style="list-style-type: none"> • Remedy
<ul style="list-style-type: none"> • YM valve (see fig. 2) does not switch back to initial position: 	<ul style="list-style-type: none"> * Check electrical connection between SR position switch and YM valve. * Replace valve
<ul style="list-style-type: none"> • Fault: Swing-out mechanism of pick-up arm already releases during pick-up of carriage 	
<ul style="list-style-type: none"> • Cause 	<ul style="list-style-type: none"> • Remedy
<ul style="list-style-type: none"> • Dampening pressure on regulator 2 is too high. • Spring washer kit does not have enough initial tension. 	<ul style="list-style-type: none"> * Reduce dampening pressure to less than 0.5 bar. * Check tightening torque.
<ul style="list-style-type: none"> • Fault: Carriage (see fig. 2, item F) does not move to initial position 	
<ul style="list-style-type: none"> • Cause 	<ul style="list-style-type: none"> • Remedy
<ul style="list-style-type: none"> • YR valve (see fig. 2) does not connect • Throttle valve K is closed. • Fault in the compressed air supply system. 	<ul style="list-style-type: none"> * Check the electrical connections and operation of the YR valve (switching phase of valve indicated by LED) * Open the throttle valve K and set the return speed. * Check the compressed air lines. * Check the inlet air pressure required (see chapter 3.5, p = 5 – 6 bar)
<ul style="list-style-type: none"> • Fault: (for all valves) Valve does not operate although LED is lit 	
<ul style="list-style-type: none"> • Cause 	<ul style="list-style-type: none"> • Remedy
<ul style="list-style-type: none"> • Valve inlet voltage too low. • Valve defective 	<ul style="list-style-type: none"> * Check the wiring diagram and the line routing * Replace the valve.
<ul style="list-style-type: none"> • Fault: Carriage (see fig. 2, item F) moves too slowly or too quickly into initial position 	
<ul style="list-style-type: none"> • Cause 	<ul style="list-style-type: none"> • Remedy
<ul style="list-style-type: none"> • Adjustment for return travel too high or too low. • COBRA inlet air pressure too low or too high. 	<ul style="list-style-type: none"> * Set the throttle valve M. * Check the inlet air pressure.

All the repairs which are beyond the knowledge of the user's personnel must be carried out by LINCOLN experts.

Service Address:

LINCOLN GmbH
Abt. Zentraler Kundendienst
Postfach 1263
D-69183 Walldorf
Tel. 06227 330
Fax. 06227 33259

Subject to modifications

6. Spare parts

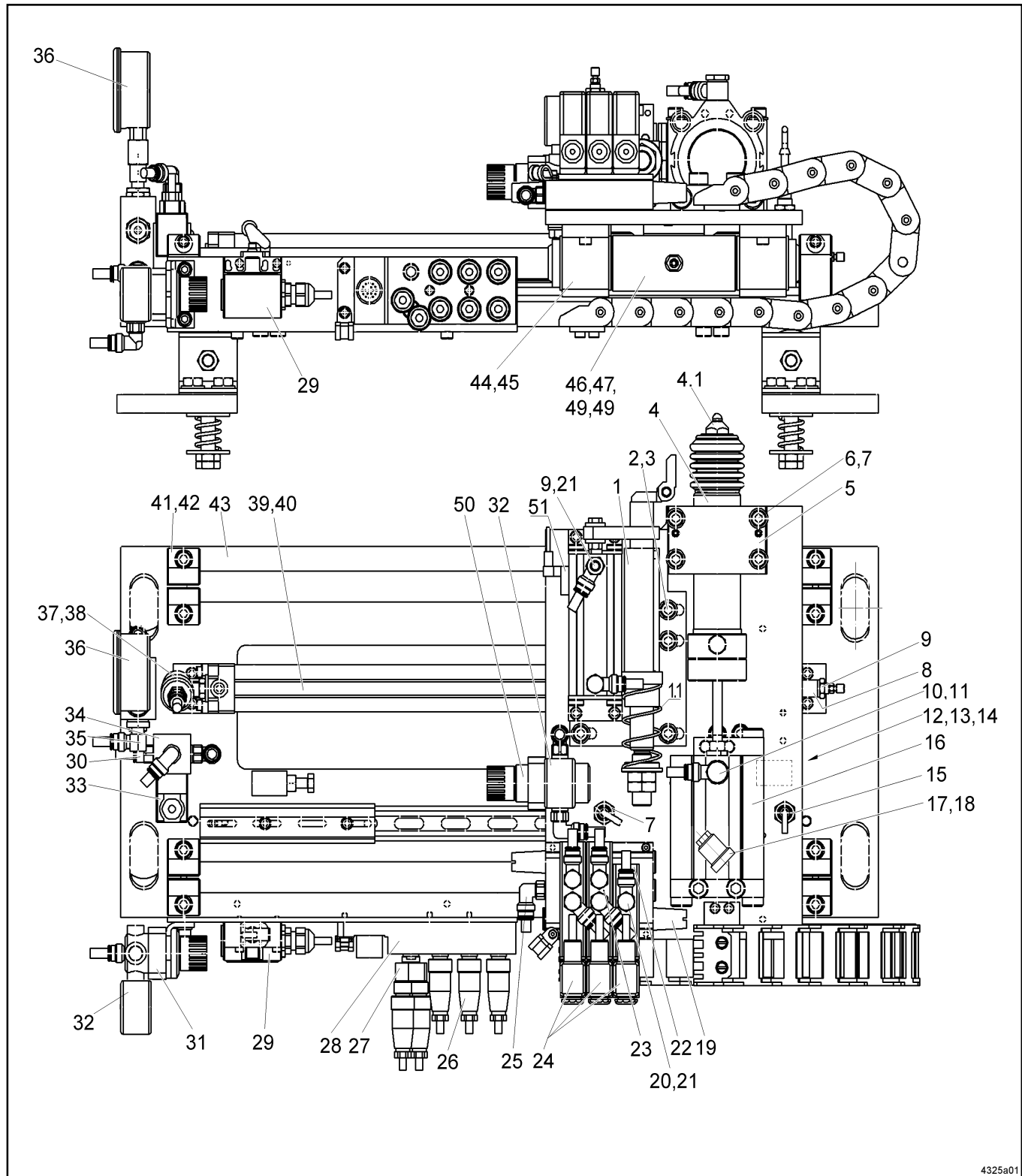

Fig. 13: Spare parts of the COBRA 501

4325a01

Subject to modifications

Item	Designation	Qty.	Part N°.
1	pick-up arm assy, without side bar, left-hand	1	580-32272-1
	pick-up arm assy, without side bar, right-hand	1	580-32273-1
1.1	pressure spring	1	218-10014-2
2	hex. socket head screw, M 8 x 16	4	201-12021-3
3	washer	4	209-13077-1
4	lubrication head assy, variant flush coupler	1	580-32268-1
	lubrication head assy, variant flush coupler with prolongation	1	580-32271-1
	lubrication head assy, variant domed-head coupler	1	580-32270-1
	lubrication head assy, variant flat coupler	1	580-32269-1
4.1	flush coupler	1	437-23181-1
	flush coupler + prolongation	1	304-19855-1
	domed-head coupler	1	437-24187-1
	flat coupler	1	580-32267-1
5	lubrication head bearing assy, variant flexible type SF (only in combination with flush coupler or domed-head coupler)	1	580-32275-1
	lubrication head bearing assy, variant rigid (only in combination with flat coupler)	1	580-32274-1
6	hex. socket head screw, M 8 x 85	4	201-12589-5
7	washer	4	209-13077-1
8	muffler ring G 1/8	1	253-14050-7
9	throttle check valve G 1/8, outgoing air	2	253-14262-1
10	hollow screw G 1/4	1	226-13777-3
11	banjo union 8-G 1/4	1	226-13778-6
12	shock absorber, hydraulic, M 14 x 1	1	233-10051-1
13	stop sleeve M 14 x 1	1	222-10052-1
14	lock nut M 14 x 1	2	207-10053-1
15	proximity switch	2	234-13155-6
16	short-stroke cylinder Ø63x50	1	253-10081-2
17	quick vent valve	1	253-14067-4
18	push-in fitting GEZ 8 - 1/4	1	226-13746-7
19	muffler G 3/8	2	253-14050-9
20	hollow screw G 1/8	6	226-13777-2
21	banjo union 8 - G 1/8	7	226-13778-1
22	3/2-way solenoid valve 338L	1	253-14263-1
23	5/2-way solenoid valve 358	2	253-14263-2
24	square plug, narrow, with LED	3	236-13869-5
25	push-in swivelling fitting WEDZ 8 - 3/8	1	226-13776-4
26	plug M 12	9	236-14229-3
27	Y-plug	1	236-13869-1
28	electric distributor	1	236-14229-2
29	ratchet gear switch	1	236-13262-9
30	push-in swivelling fitting WEDZ8 - 1/8	2	226-13776-2
31	pressure regulator Micro	1	253-14459-6
32	pressure gauge	2	234-13103-2
33	square plug, wide, with LED	1	236-13869-1
34	3/2-way valve G 1/8	1	235-13109-4
35	push-in swivelling fitting WEDZ 8 - 1/8	6	226-13776-5
36	pressure gauge	1	234-13182-2
37	quick vent valve G 1/8	1	253-14067-7
38	push-in fitting GEZ 8 - 1/8	1	226-13746-5
39	cylinder without piston rod Ø 25 x 305	1	253-10081-1
40	closure plug Camozzi S2610-1/8	6	226-13797-4
41	shaft support (with clamping screw)	4	250-10090-3
42	hex. socket head screw M 8 x 40	8	201-12021-5
43	shaft Ø 25 x 570	2	250-10090-2
44	slide bearing	4	250-10090-1
45	hex. socket head screw M 6 x 20	8	201-12018-5
46	distance tube	2	480-24937-1
47	O-ring Ø 40 x 1,5	4	219-12224-7
48	hydr. lubrication fitting, straight, G 1/8	2	251-14040-2
49	closure plug G 1/8	2	303-17445-1
50	pressure regulator Mini	1	253-14262-2
51	proximity switch	1	234-13177-1

Subject to modifications

Spare Parts Assy SPL (Swinging Plate)

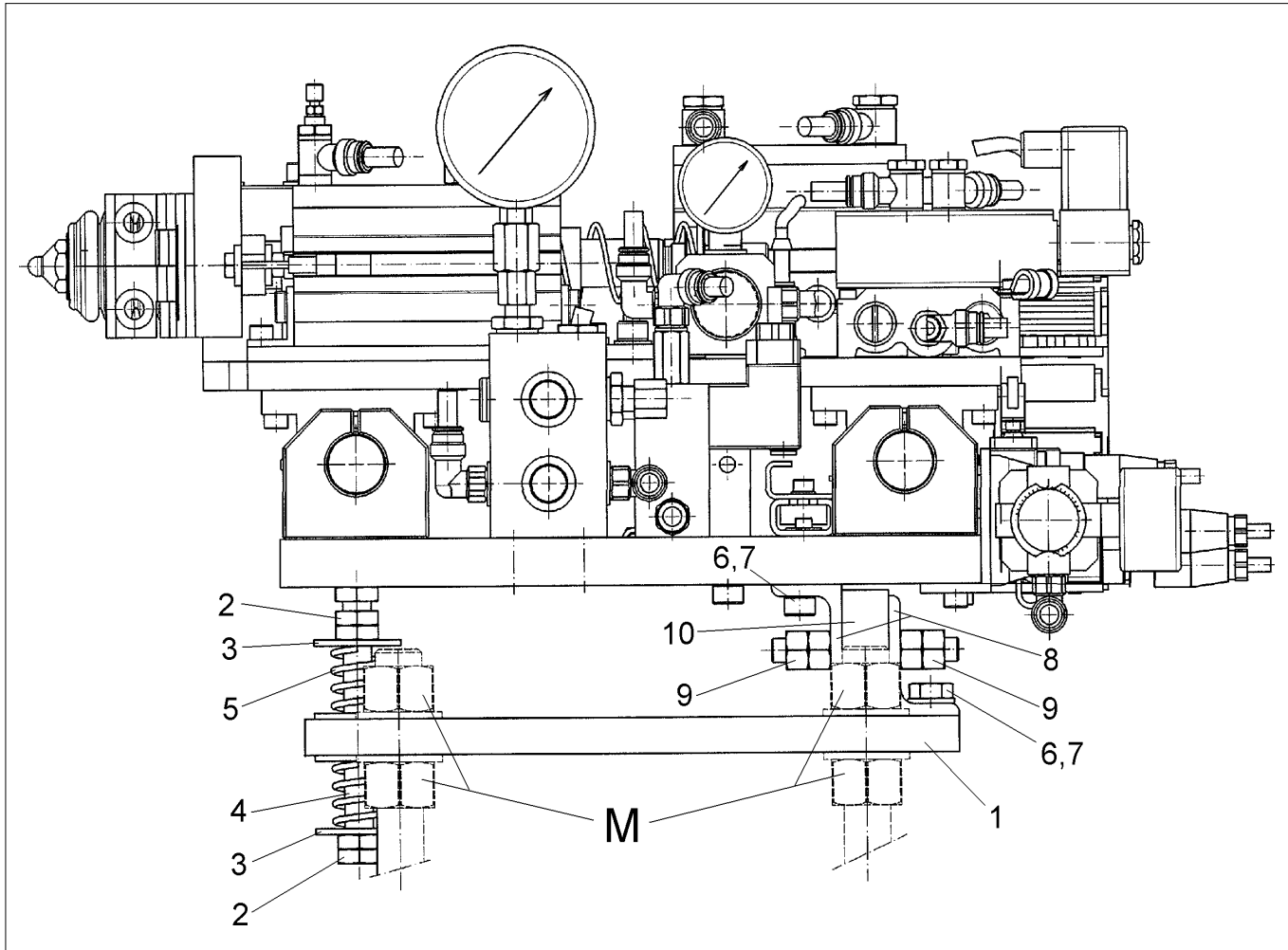

Item	Designation	Qty.	Part N°.
1	fixing plate	2	480-24913-1
2	hex. head screw M 12	10	207-12142-3
3	spring washer	8	480-70000-1
4	threaded rod M 12 x 145	2	480-70019-1
5	pressure spring	4	218-10014-4
6	hex. head screw M 10 x 20	8	200-12523-2
7	washer	8	209-13077-2
8	elbow	4	480-24915-1
9	hex. head screw M 10	8	207-12136-1
10	vibration damper	2	233-13073-4

Subject to modifications