

High-Pressure Central Lubrication pump ZPU09/09A

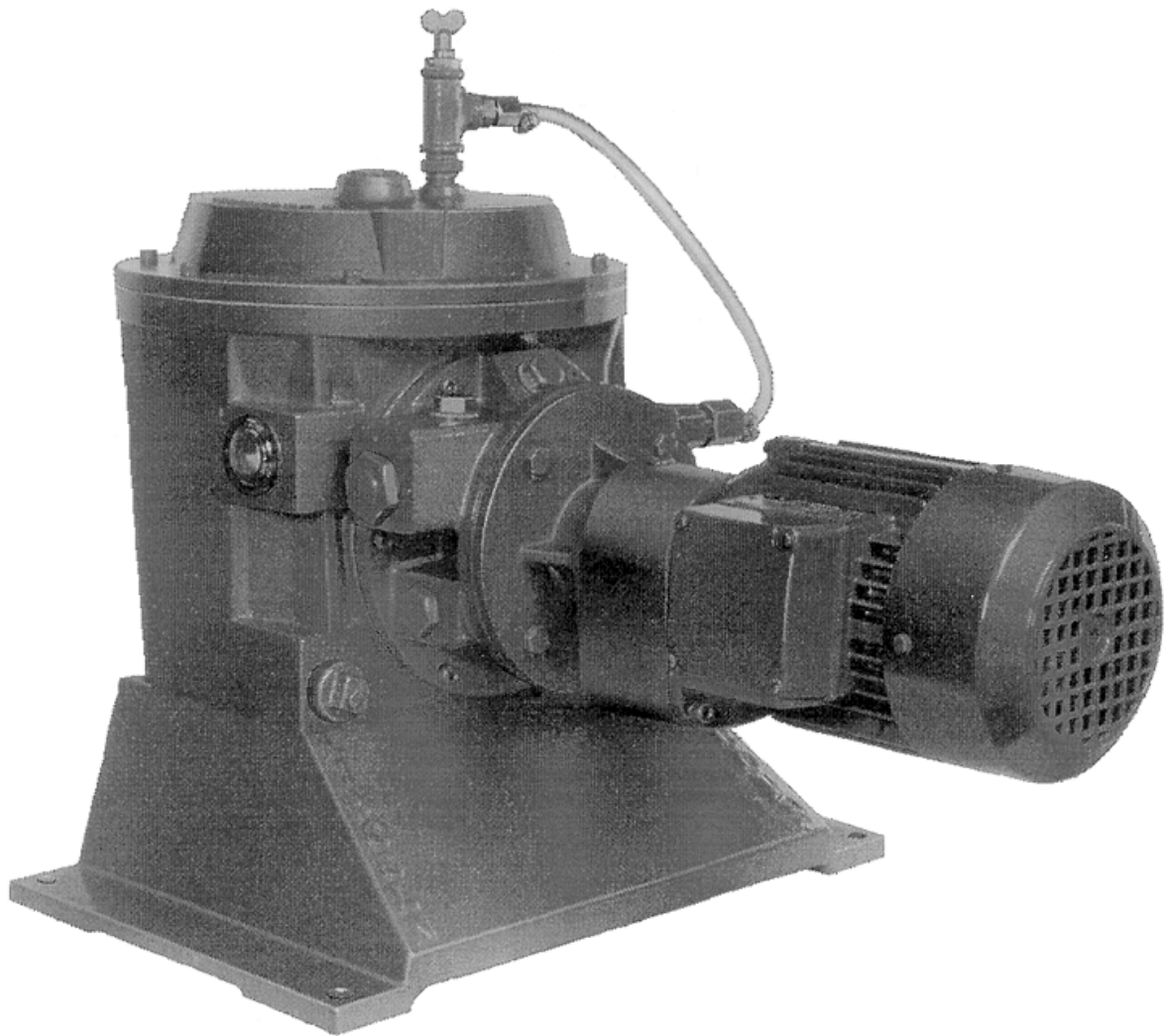

Subject to change without notice

1013b93

Preface to the Owner Manual

This Owner Manual is intended to familiarize the user with the pump/lubrication system and to enable him to use its various features.

The Operating Instructions contain important information for safe, correct and economic operation of the pump/lubrication system. Their observance will help avoid hazards, reduce repair costs and downtime, increase the reliability and prolong the service life of the pump/lubrication system.

These Operating Instructions must be completed to include the respective national regulations concerning the prevention of accidents and protection of the environment.

The Owner Manual must always be available on the site where the pump/lubrication system is in operation.

If persons who are charged with work with the pump/lubrication system do not have a good command of the German language, it is the user's responsibility to take the necessary action to make the Owner Manual, particularly the Operating Instructions, understandable to these persons.

The Owner Manual must be read and used by all persons who are charged with work with the pump/lubrication system, e.g.

- **Operation**, including adjustment, troubleshooting during operation, elimination of production waste, maintenance, disposal of process materials
- **Maintenance** (inspection, repairs)

Table of Contents

| Item | Page | Item | Page |
|--------------------------------------|------|---------------------------------------|------|
| 1 Safety Instructions | 3 | 4 Operating Instructions | 9 |
| 2 Description | 5 | 4.1 Commissioning | 9 |
| 2.1 General | 5 | 4.2 Maintenance and Repairs | 10 |
| 2.2 Appropriate Use | 5 | 4.3 Troubleshooting | 11 |
| 2.3 Technical Data | 5 | 5 Spare Parts List | 12 |
| 2.4 Structure | 6 | 6 Accessories | 15 |
| 2.5 Electrical Equipment | 7 | 6.1 Pressure Switch | 15 |
| 2.6 Mode of Operation | 7 | 6.2 Dimensional Drawing | 16 |
| 3 Erection and Assembly | 9 | 6.3 Motor Data sheet | 17 |
| 3.1 Erection of the Pump | 9 | | |
| 3.2 Electrical Connection | 9 | | |

Subject to change without notice

Safety Instructions

6.5A-18001-A96

1 Safety Instructions

The Operating Instructions include general instructions which must be followed when a pump/pump unit is installed, operated or serviced. Therefore, it is absolutely necessary for the fitter and the specialist/user to read the Operating Instructions before a unit is installed and commissioned. The Operating Instructions must always be available on the site where the machine/system is erected.

All general safety instructions contained in this main chapter on safety must be observed as well as all special safety instructions given in other main chapters.

Hazard warnings in the Operating Instructions

The notes referring to safety contained in the Operating Instructions whose failure to observe may result in personal injury are marked by the following symbol

Safety symbol acc. to DIN 4844-W9



The symbol

Staff Qualification and Training

The staff responsible for operation, maintenance, inspection and installation must be adequately qualified for these jobs. The user must properly regulate the field of responsibility and supervision of the personnel. If the personnel is not in command of the necessary expertise, they must receive appropriate training and instructions.

If necessary, this can be done by the manufacturer/supplier on behalf of the machine user. Furthermore, the user must ensure that the contents of the Operating Instructions are fully understood by the personnel.

Hazards resulting from failure to observe the safety instructions

Failure to heed the safety warnings may result in damage to equipment and the environment and/or personal injury. Failure to observe the safety notes may result in the loss of all claims for damage.

As an example, in the following we list some dangers which may result from failure to observe the warnings:

- failure of machine/system to fulfill important functions
- failure of specified methods for maintenance and repair
- personal injury due to electrical, mechanical and chemical influences
- danger to the environment due to leakage of harmful materials

Safety symbol acc. to DIN 4844-W8

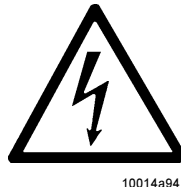

warns of an electrical hazard.

If ignoring the safety note might result in machine damages and malfunction, the word

is added.

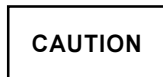

Warnings directly fixed to the machine must always be observed and must be kept in completely legible condition.

Safety-Conscious Working

The safety instructions given in the Operating Instructions, the prevailing national regulations for the prevention of accidents and any internal working and shop regulations and accident prevention measures of the user must be observed.

Safety Instructions for the User/Operator

- If warm or cold machine parts may involve hazards, the customer must protect them against accidental contact.
- Do not remove protection devices for moving parts while the machine is in operation
- Leakages of harmful materials must be disposed of so as to jeopardize neither persons nor the environment. The requirements of the law must be satisfied.
- Danger caused by electrical current must be excluded (for details refer to the applicable specifications of VDE and the local power supply companies).

Subject to change without notice

Safety Instructions

6.5A-18001-A96

Safety Instructions for Maintenance, Inspection and Installation Services

The user must make sure that all maintenance, inspection and installation work is executed by authorized and qualified experts who have thoroughly read the Operating Instructions

On no account may work be done on the machine while the machine is in operation. Follow all instructions for shutting down the machine as described in the Operating Instructions. Decontaminate pumps and pump units delivering harmful materials.

Reassemble all safety and protection devices immediately after completion of the cleaning procedure.

Dispose of material harmful to the environment in accordance with the applicable official regulations.

Before putting the pump/pump unit into operation, ensure that all points given in the chapter „Commissioning“ are observed.

Unauthorized Modification and Spare Parts Production

Alteration and modifications of the machine are only allowed if approved by the manufacturer. Original spare parts and accessories authorized by the manufacturer ensure safe operation. If other parts are used, the manufacturer may be released from liability for the resulting consequences.

Inadmissible Operating Modes

The operational safety of the supplied product is only granted if the product is operated according to the instructions given in chapter 1 - General - of the Operating Instructions. The max. ratings listed in the Technical Data sheet must never be exceeded.

Commissioning of the product (pump/pump unit) within the European Union is forbidden until it has been decided that the machine in question meets the requirements of the EU guidelines.

Description

6.5A-18001-A96

2 Description

2.1 General

This Owner Manual only refers to high-pressure central lubrication pumps of the series ZPU 09/09A.

It is intended for the personnel in charge of the installation, operation and maintenance of the pump.

If faults should occur although the Operating Instructions have been followed, please contact our Service Department below:

LINCOLN GMBH
 Abt. Zentraler Kundendienst
 Postfach 1263
 D-69183 Walldorf
 Tel +49 (6227) 33-0
 Fax +49 (6227) 33-259

2.2 Appropriate Use

The high-pressure oil pump model ZPU 09 is designed for use in hydrostatic lubrication systems only.

Take care that the max. ratings mentioned in the Technical Data, particularly the max. operating pressure of 400 bar, is not exceeded.

Any other use is not in accordance with the instructions and will result in the loss of claims for guarantee or liability .

2.3 Technical Data

| | |
|--------------------------------|---|
| Number of outlets | 1 (ZPU09) 2 (ZPU09A) |
| Lubricant output | 8 dm ³ /h (ZPU09) 2x4 dm ³ (ZPU09A) |
| Operating pressure | pmax = 400 bar |
| Drive speed | 60 rpm |
| Direction of rotation of drive | optional |
| Reservoir capacity | 8 dm ³ |
| Suitable lubricants | industrial lubrication oils with a viscosity of min. 20 to max. 460 mm ² /s acc. to DIN 51519 (other viscosities on request) |
| Safety valve | fixed to 410 bar tamper-proof |
| Drive motor | refer to Motor Data Sheet |
| Sound level | < 70 dB(A) |
| Connection threads | pressure line 3/8"BSP filling line 3/4"BSP |

Note: In the case of 60 Hz motors the speed and thus the lubricant output may be less then the theoretical value calculated.

Description

6.5A-18001-A96

2.4 Structure

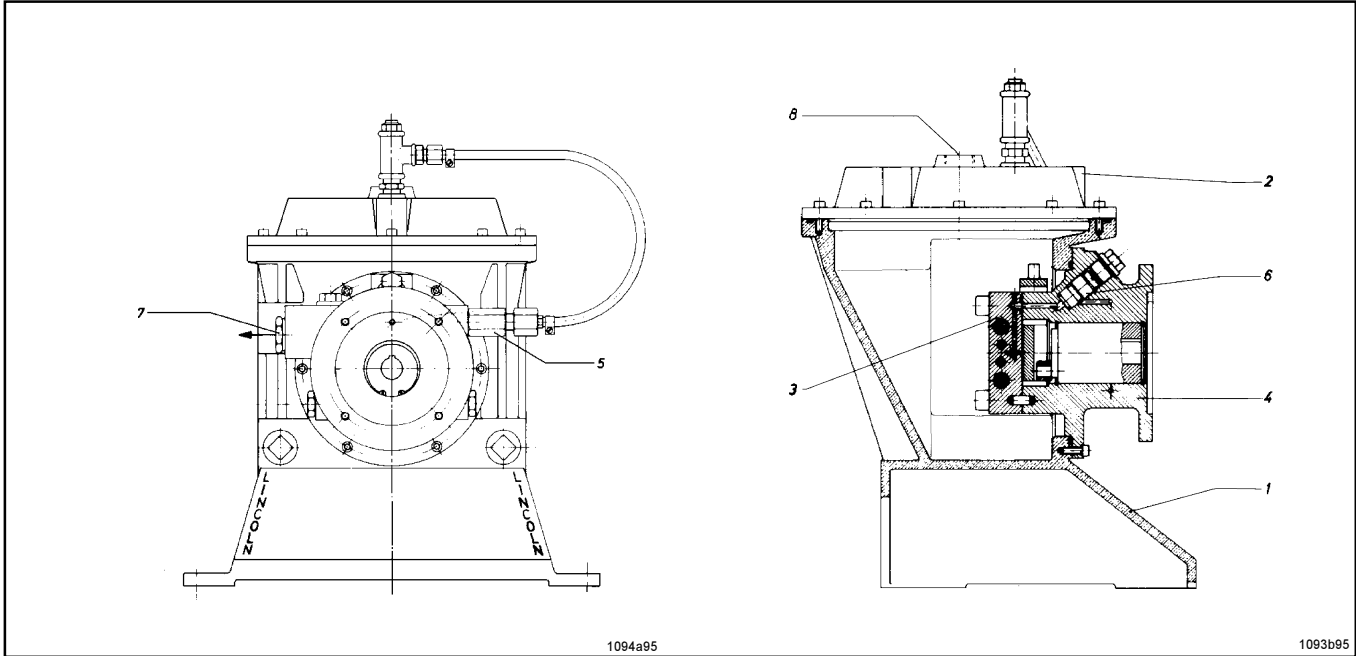

Fig. 2.4.1: Sectional drawing of pump ZPU09 ZPU 09

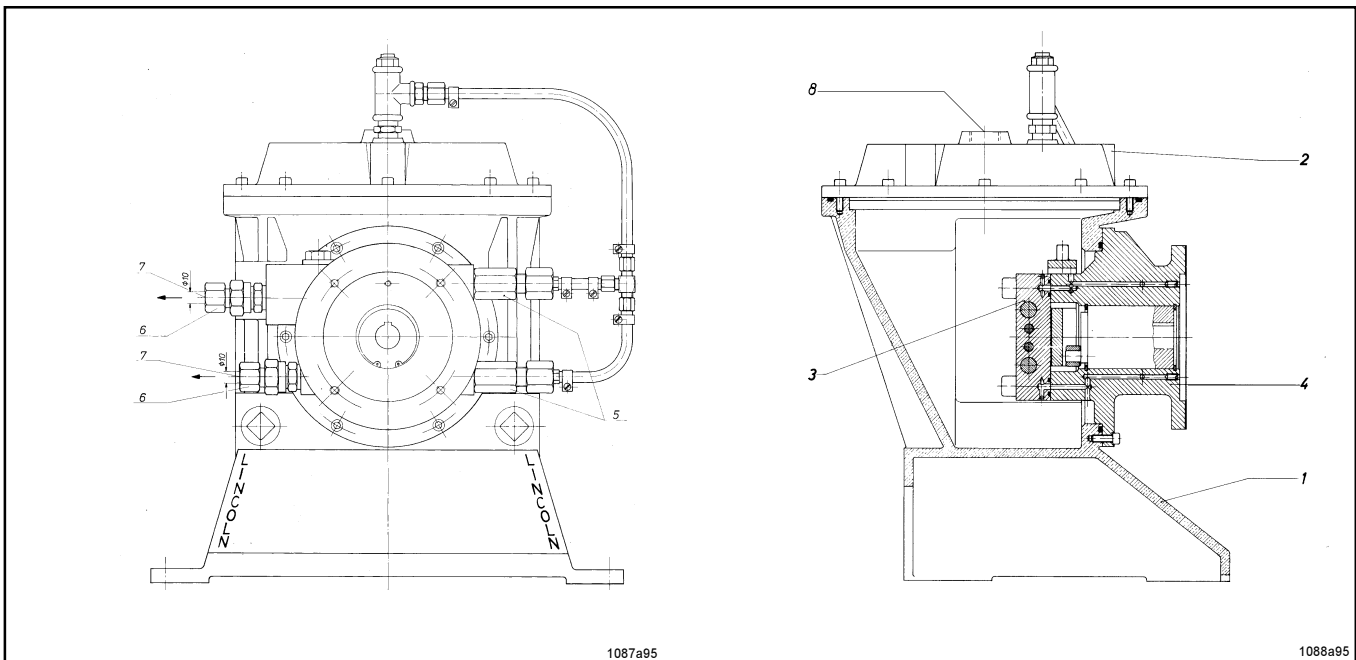

Fig. 2.4.2: Sectional drawing of pump ZPU09A

The pump ZPU09/09A mainly consists of:

| Item | Designation | Item | Designation |
|------|----------------------------|------|--------------------------|
| 1 | pump housing | 5 | safety valve |
| 2 | cover | 6 | check valve |
| 3 | high pressure pump element | 7 | pressure line connection |
| 4 | bearing flange with drive | 8 | filling connection |

Subject to change without notice

Description

6.5A-18001-A96

2.5 Electrical Equipment

Flanged gear motor: technical data mentioned in enclosed motor data sheet

2.6 Mode of Operation

The pump element operates as a piston pump with 2 pistons operating in opposite direction which suck in lubricant alternately and then feed it through the outlet hole to the pressure line.

The pump element is driven by a hollow shaft with eccentric pin and roller, by which the rotary movement of the driving shaft is converted into the oscillating movement of the pump pistons. With this kind of drive, the direction of rotation of the pump shaft is therefore optional.

The lubricant supplied by the pump element is fed via a check valve to the pressure line connection (item 7). A safety valve (item 5) is also connected with the pressure line connection.

Description

6.5A-18001-A96

Description of Operation of High-Pressure Pump Element for Pumps ZPU09

The pump element operates as a piston pump with two pistons operating in opposite direction which suck in lubricant alternately and feed it through the outlet hole to the pressure line. The outlet channels of the high-pressure pistons are controlled by a floating piston.

The pump element is driven by a hollow shaft with eccentric pin and roller, by which the rotary movement of the driving shaft is converted into the oscillating movement of the pump pistons

Legend:

- 1, 2 = delivery piston
- 3 = floating piston
- I = suction hole for delivery piston 1
- II = suction hole for delivery piston 2
- III = outlet hole (pressure line connection)

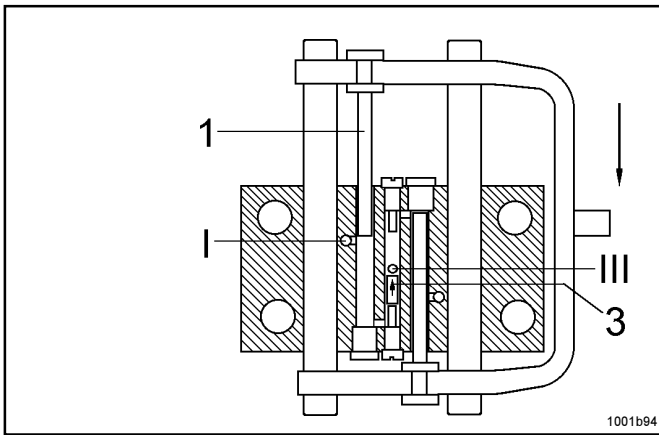

(Fig. 2.6.1 Upper final position)

The piston begins to move downwards

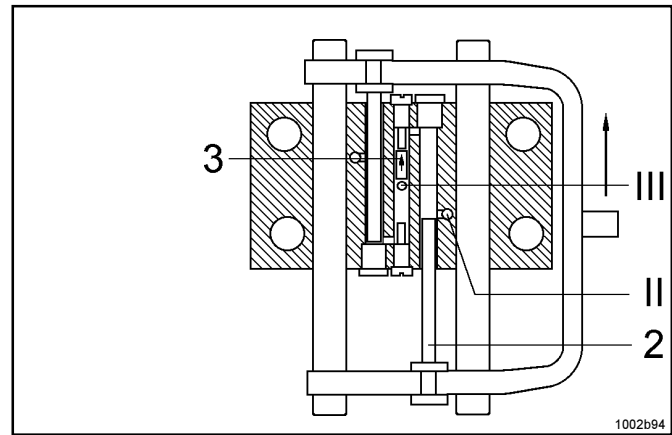

(Fig. 2.6.3 Lower final position)

The piston begins to move upwards

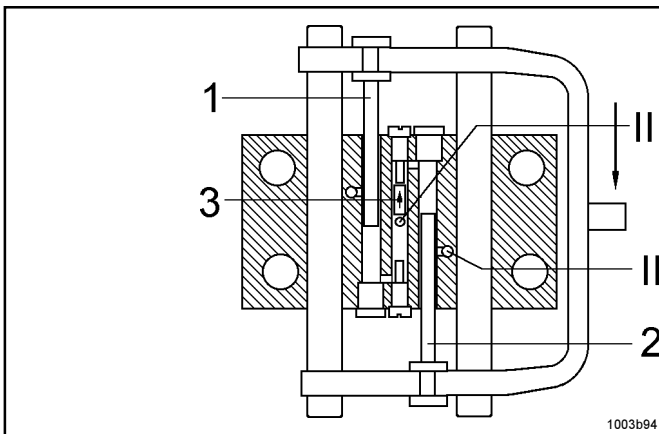

(Fig. 2.6.2 discharge stroke upwards)

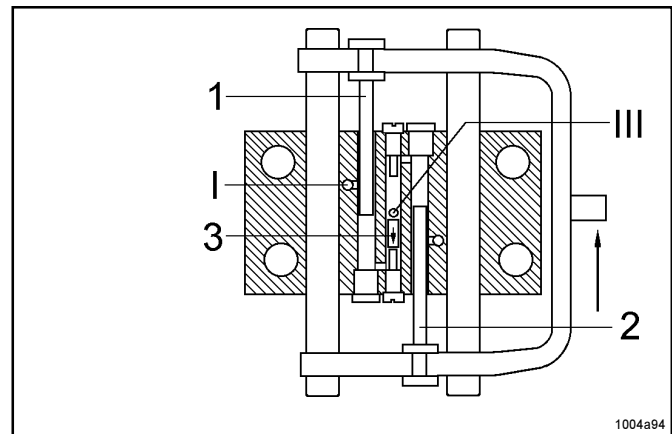

(Fig. 2.6.4 discharge stroke downwards)

Delivery piston 1 displaces floating piston 3 upwards, together with the lubricant stored from the preceding suction stroke. Lubricant is delivered into the pressure line via the outlet hole which is now opened.

A vacuum is generated by delivery piston 2 with the result that lubricant is sucked in after hole II has been opened.

Delivery piston 2 displaces the floating piston downwards, together with the lubricant stored from the preceding suction stroke.

The lubricant is fed into the pressure line.

Delivery piston 1 sucks in lubricant.

The pump element of pump ZPU09A operates in a similar way, the difference being however that the control piston alternately closes one of two outlet holes while it opens the other one. To each delivery piston, one separate outlet hole is allotted which is led in the flange to the outside check valve.

Subject to change without notice

Erection and Assembly / Operating Instructions

6.5A-18001-A96

3 Erection and Assembly

3.1 Pump Erection

Requirements on the place of installation

- protected from dust and dirt
- safe against atmospheric influences
- enough space for connecting the tube lines and executing the maintenance work (the required space depends on the pump size)
- even, solid and vibration-free place of erection

3.2 Electrical Connection

All electrical work should be undertaken only by qualified personnel

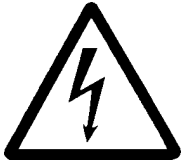

Electrical connection of the drive motor:

- terminal diagram in cover of terminal box
- fuse protection in conformity with the national regulations in force. Nominal current consumption mentioned in enclosed motor data sheet.

4 Operating Instructions

4.1 Commissioning

Connection of the tube lines and pump filling

Connect the pressure line and relief line to the pump by means of adequate fittings.

- Take care that no dirt or foreign particles enter the pump housing
- Clean the tube lines before connecting them
- Avoid dirt in the pump area



Then, fill pump with oil

Venting and Putting Into Operation

Open air release cock (item 35 spare parts list) until oil emerges without air bubbles.

Let pump run about 5 minutes without backpressure.

Then, vent pump housing by opening air release cock.

All system components connected downstream of the pump (tube lines, tube fittings, hoses) must be designed for the max. system pressure.



4.2 Maintenance and Repairs

Repair work should be undertaken only by qualified personnel using original spare parts

Before executing any repair on the pump, take care of the following:



- 1 Switch drive motor off and secure it against inadvertent restart. Risk of injury by the stirring paddle
- 2 Close shut-off valve in pressure line and filling line.
- 3 Decrease the pressure in the pump and system down to 0 by loosening the pressure connection fitting. Risk of injury due to lubricant splashing
- 4 Let the oil flow from the pump housing (closure plug on the front side of the pump)

Under the condition that the pump only supplies clean oil, it does not need any particular maintenance. The pump element lies in the oil which is supplied and it is lubricated automatically. It is subject to natural wear which depends on the working time and adjusted pressure.

Maintenance work

- Replacement of the check valve (spare parts list item 24) about every 100 operating hours. For this, first remove closure plug item 25.

To ensure service life, the gears of the flanged motors are filled with oil in the factory.

4.3 Troubleshooting

Note: The following only describes pump failures. Failures due to electrical malfunctioning or system malfunction are indicated in the System Description.

• Fault: pump does not supply the lubricant

- | | |
|--|---|
| <ul style="list-style-type: none">• Cause:• No oil in the system• Eccentric shaft damaged or defective• Suction borehole of pump element clogged | <ul style="list-style-type: none">• Remedy:• Check oil flow to the pump. Open venting valve and vent pump housing• Replace damaged parts• Disassemble pump element, clean it and check whether foreign particles are lodged in the pump element |
|--|---|

• Fault: pump runs, but there is no pressure

- | | |
|---|--|
| <ul style="list-style-type: none">• Cause:• Check valve (item 7) clogged or defective• Pump element (item 4) damaged or worn | <ul style="list-style-type: none">• Remedy:• Replace check valve• Replace pump element <i>Note: The pump element cannot be repaired since its pistons are precision-fitted in our factory</i> |
|---|--|

• Fault: oil leaking from the safety valve

- | | |
|--|---|
| <ul style="list-style-type: none">• Cause:• Blockage in the pressure line system | <ul style="list-style-type: none">• Remedy:• Check tube lines. Eliminate blockage |
|--|---|

All repairs which are beyond the knowledge of the user's personnel must be executed by Lincoln's specialists. For this, either send the defective pump back to the Repair Department of our Walldorf factory or call a specialist for the repair on site.

Service Address:

LINCOLN GMBH
Customer Service
Postfach 1263
D-69183 Walldorf
Tel +49 (6227) 33-0
Fax +49 (6227) 33-259

Subject to change without notice

Spare Parts Drawing and Spare Parts List

6.5A-18001-A96

5 Spare Parts Drawing and Spare Parts List

5.1 High-Pressure Central Lubrication pump ZPU09



Abb 5.1.1: High-Pressure Central Lubrication pump ZPU 09

without driving assemblies

| Item | Description | Quantity | Part No. | Item | Description | Quantity | Part No. |
|------|----------------------------------|----------|-------------|------|---------------------------------|----------|-------------|
| 1 | cover | 1 | 314-18595-1 | 20 | safety valve | 1 | 624-27092-1 |
| 2 | hexagon socket head screw | 8 | 201-12018-5 | 21 | sealing ring | 1 | 226-12491-4 |
| 3 | sealing ring | 8 | 209-12158-1 | 22 | pump connection | 1 | 226-12491-6 |
| 4 | O-ring | 1 | 219-12227-1 | 23 | hose clamp | 2 | 226-12334-1 |
| 5 | casing | 1 | 314-19305-1 | 24 | check valve, with items 26 + 28 | 1 | 505-36089-1 |
| 6 | sealing ring | 1 | 233-13005-6 | 25 | closure plug | 1 | 203-12077-3 |
| 7 | oil level indicator, with item 6 | 1 | 233-13005-1 | 26 | sealing ring | 1 | 209-12158-4 |
| 8 | O-ring | 1 | 219-12226-5 | 27 | check valve | 1 | 524-30812-1 |
| 9 | closure plug | 2 | 203-12095-2 | 28 | O-ring | 1 | 219-13043-8 |
| 10 | hexagon socket head screw | 4 | 201-12028-4 | 29 | hexagon socket head screw | 6 | 201-12018-5 |
| 11 | pump element with item 12 | 1 | 505-30405-3 | 30 | closure plug | 1 | 303-19310-1 |
| 12 | O-ring | 1 | 219-13043-7 | 31 | sealing ring | 1 | 209-12464-8 |
| 13 | reducing bushing | 1 | 222-12578-9 | 32 | GERV6-SG 1/4A LC | 1 | 223-12372-9 |
| 14 | closure plug | 1 | 303-17440-1 | 33 | hose stud | 1 | 405-20319-2 |
| 15 | bearing flange | 1 | 315-19312-1 | 34 | plastic hose | 1 | 111-35065-2 |
| 16 | roller | 1 | 405-23544-1 | 35 | venting valve (with wrench) | 1 | 233-13003-3 |
| 17 | eccentric shaft | 1 | 405-20316-2 | 36 | reducing T-piece | 1 | 222-12260-2 |
| 18 | retaining ring | 1 | 211-12165-6 | 37 | equal nipple | 1 | 222-12257-6 |
| 19 | sealing ring | 1 | 306-17856-1 | 38 | protective plug | 1 | 233-13100-6 |

Subject to change without notice

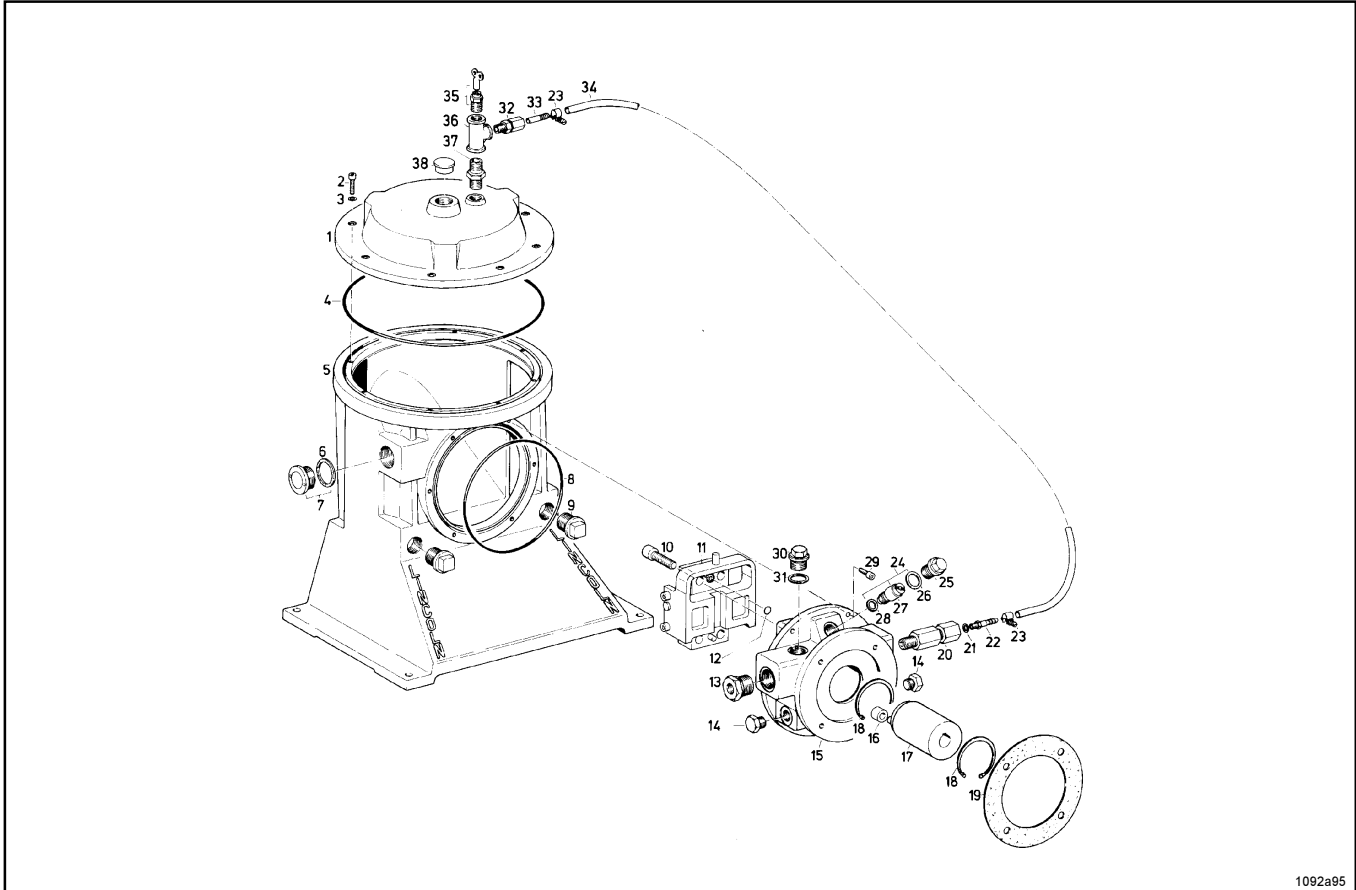
Spare Parts Drawing and Spare Parts List

6.5A-18001-A96

5.2 High-Pressure Central Lubrication pump ZPU09A

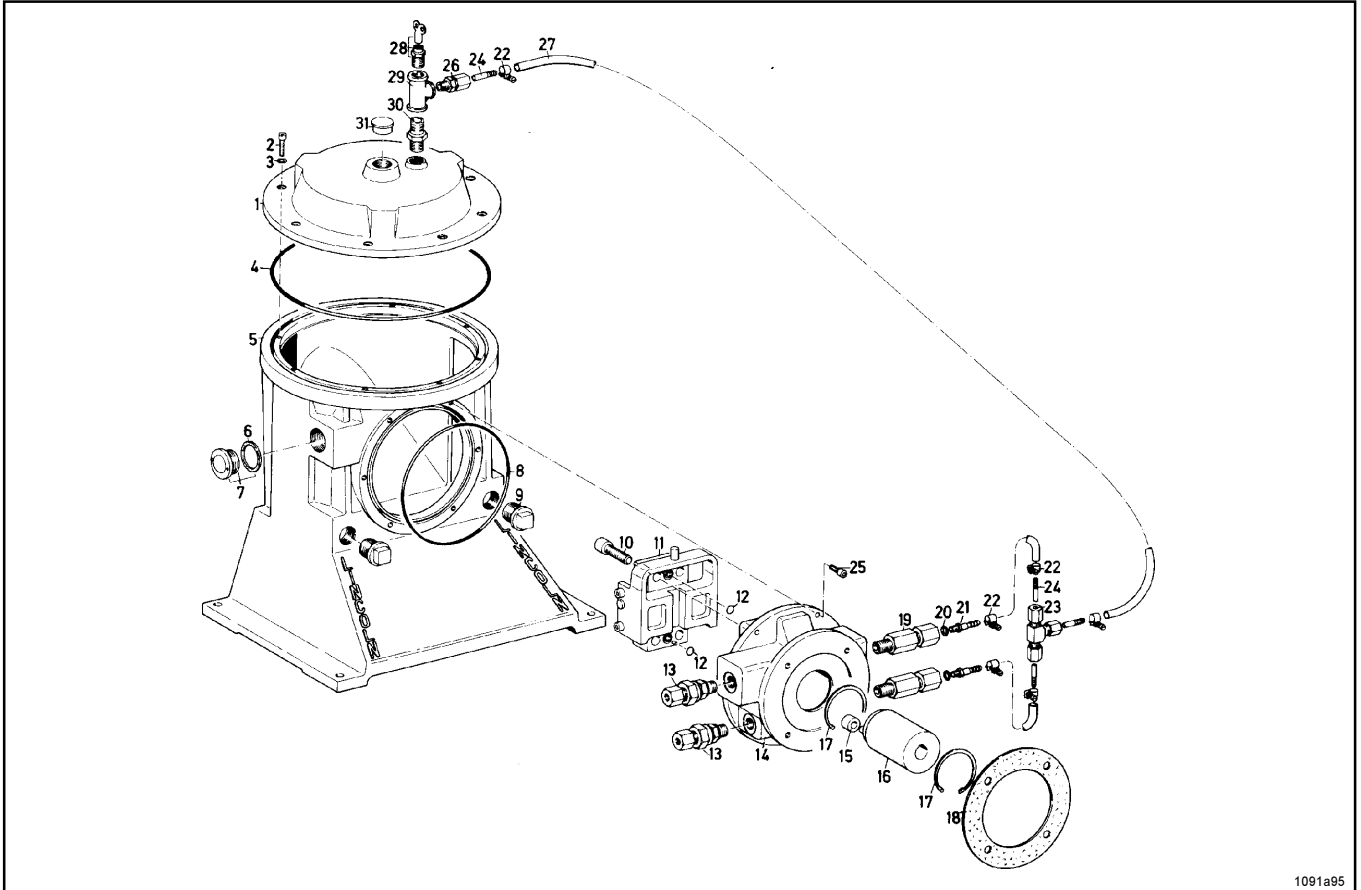

Fig.5.2.1: High-Pressure Central Lubrication pump ZPU 09A

1091a95

without driving assemblies

Subject to change without notice

| Item | Description | Quantity | Part No. | Item | Description | Quantity | Part No. |
|------|----------------------------------|----------|-------------|------|-----------------------------|----------|-------------|
| 1 | cover | 1 | 314-18595-1 | 17 | retaining ring | 2 | 211-12165-6 |
| 2 | hexagon socket head screw | 8 | 201-12018-5 | 18 | sealing ring | 1 | 306-17856-1 |
| 3 | sealing ring | 8 | 209-12158-1 | 19 | safety valve | 1 | 624-27092-1 |
| 4 | O-ring | 1 | 219-12227-1 | 20 | sealing ring | 2 | 226-12491-4 |
| 5 | casing | 1 | 314-19305-1 | 21 | pump connection | 1 | 226-12491-6 |
| 6 | sealing ring | 1 | 233-13005-6 | 22 | hose clamp | 1 | 226-12334-1 |
| 7 | oil level indicator, with item 6 | 1 | 233-13005-1 | 23 | T-union | 1 | 223-12484-9 |
| 8 | O-ring | 1 | 219-12226-5 | 24 | hose stud | 1 | 405-20319-2 |
| 9 | closure plug | 2 | 203-12095-2 | 25 | hexagon socket head screw | 6 | 201-12018-5 |
| 10 | hexagon socket head screw | 4 | 201-12028-4 | 26 | GERV6-SG 1/4 A LC | 1 | 223-12372-9 |
| 11 | pump element with item 12 | 1 | 505-30884-1 | 27 | plastic hose | 1 | 111-35065-2 |
| 12 | O-ring | 2 | 219-13043-7 | 28 | venting valve (with wrench) | 1 | 233-13003-3 |
| 13 | check valve | 2 | 505-30447-1 | 29 | reducing T-piece | 1 | 222-12260-2 |
| 14 | bearing flange | 1 | 315-19366-1 | 30 | equal nipple | 1 | 222-12257-6 |
| 15 | roller | 1 | 405-23544-1 | 31 | protective plug | 1 | 233-13100-6 |
| 16 | eccentric shaft | 1 | 405-20316-2 | | | | |

Spare Parts Drawing and Spare Parts List

6.5A-18001-A96

5.2 Driving assemblies for central lubrication pump
 ZPU 09/09A

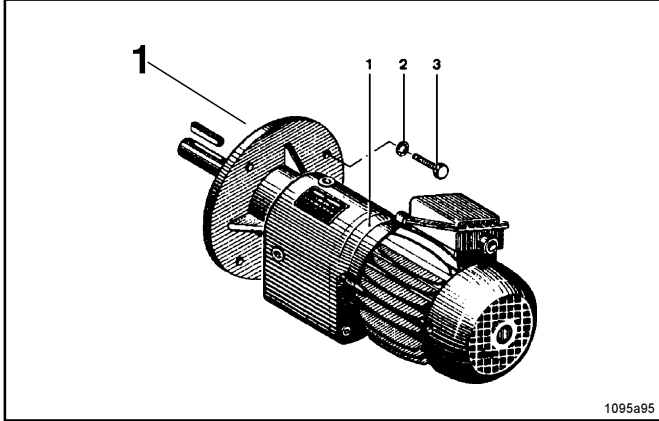

| Item | Designation | Qty. | PartNumber |
|---|--|------|-------------|
| Drive assemblies for central lubrication pump ZPU 08 (1) | | | |
| 1 | Assembly for drive with gear motor Flanged gear motor 0.37 kW, , 380-415V/50 Hz, 60 rpm 420-480V/60 Hz, 72 rpm or flanged gear motor 0.37 kW, 500 V 50 Hz, 60 rpm | 1 | 245-13575-1 |
| 2 | Tooth lock washer | 4 | 210-12161-8 |
| 3 | Hexagon head screw | 4 | 200-12007-5 |

Appendix

6.5A-18001-A96

6 Appendix

6.1 Pressure Switch

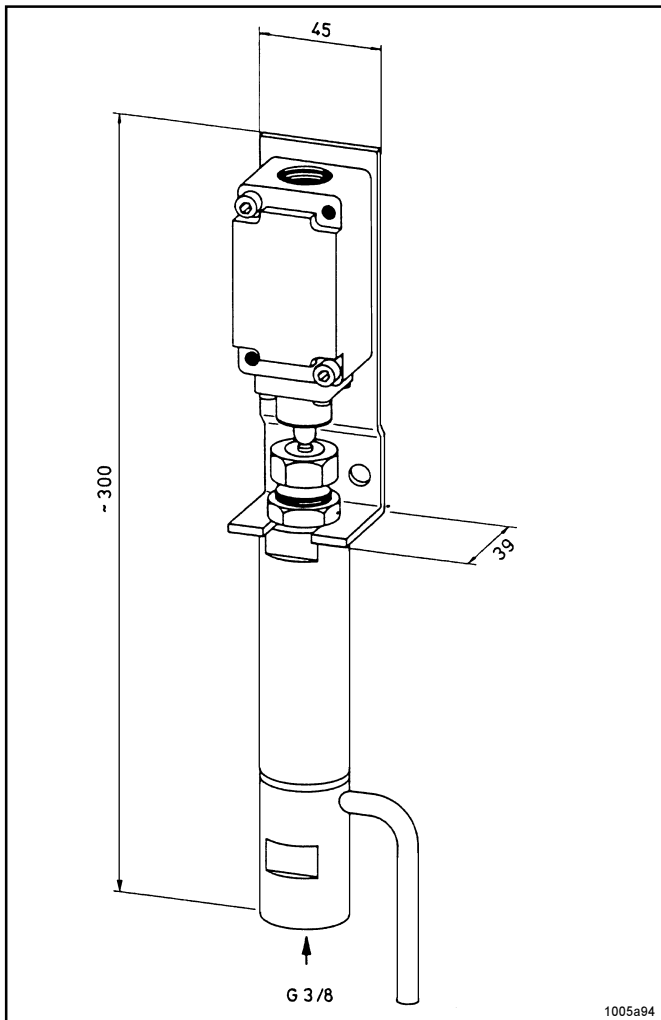

Adjustment of pressure switch:

Before adjusting the pressure switch, switch off current supply to lubrication pump.

After loosening counter nut SW 27, re-adjust the spring tension.

On turning set screw SW 24 clockwise, the compression spring is tensed and the switching pressure is increased. Inverse procedure will result in a pressure decrease.

Scope of delivery:

As illustrated, please indicate the piston diameter when ordering

To be supplied by customer:

Wiring of limit switch to switch cabinet by means of oil-resisting cable 3 x 1.5 mm²

| Pressure range | Pressure reducer Piston and cylinder DIA | Compression spring Wire DIA | Part Num. |
|----------------|--|-----------------------------------|-----------|
|----------------|--|-----------------------------------|-----------|

| | | | |
|---------------|-------|--------|-------------|
| 160 - 400 bar | 6 mm | 4.0 mm | 623-25461-2 |
| 50 - 115 bar | 10 mm | 4.0 mm | 623-25456-2 |
| * 0 - 15 bar | 16 mm | 3.0 mm | 623-25801-2 |

*Connection thread 1/2" BSP, further types of pressure range on request
 Limit switch: 1 NC contact, 1 NO contact

Subject to change without notice

6.2 Dimensional Drawing

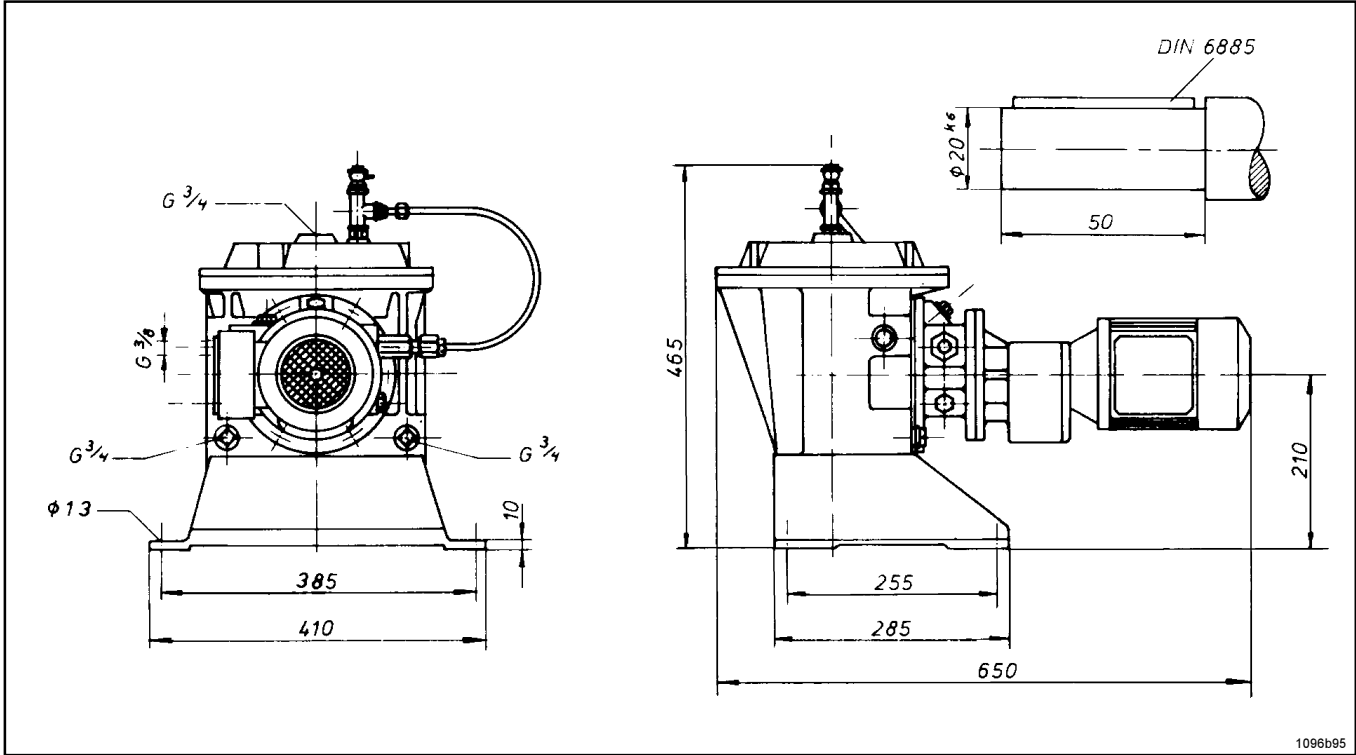

Fig. 6.2.1: Dimensional Drawing ZPU09

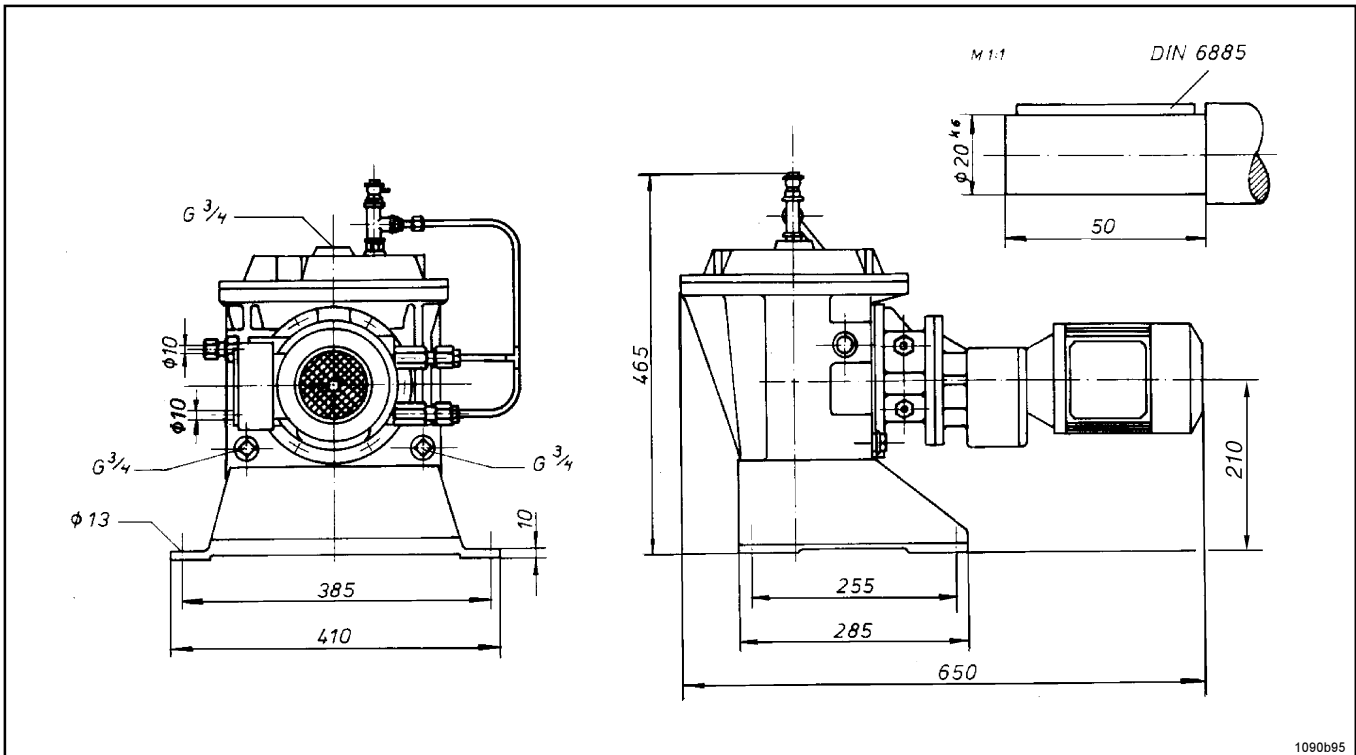

Fig. 6.2.1: Dimensional Drawing ZPU09A

Subject to change without notice

Motor Data Sheet

Standard Multi-Range Three-Phase AC Asynchronous Gear Motors

| | | | |
|------------------------------------|--------------------------------|--------------|----------------------|
| Pump model | | ZPU09 | Units |
| Motor manufacturer | | ABM | |
| Motor type | | G80F/D71B-4 | |
| Part-No. | | 245-13575-1 | |
| Frequency | f | 50 | [Hz] |
| Nominal power | P | 0.37 | [kW] |
| Nominal speed | n1/n2 | 1370/60 | [min ⁻¹] |
| Rated torque | M | 59 | [Nm] |
| Nominal current | I _N | 1.80 | [A] at 220-240 V |
| | | 1.05 | [A] at 380-415 V |
| Starting current/ ratio | I _A /I _N | 3.9 | [A] |
| Power factor | cos φ | 0.73 | |
| Efficiency | η | 0.72 | [%] |
| Frame size | | 71S | |
| Type of construction | | B5 A1/160 | |
| Type of protection | IP | 55 | |
| Insulation class | | F | |
| Weight | | ca. 11 | [kg] |
| Flange | | Ø160 | [mm] |
| Shaft end | | Ø20X50 | [mm] |

The motor can be connected to the following networks:

- 220/380 V ± 5%, 50Hz
- 230/400 V ± 5% and ± 10%, 50Hz
- 240/415 V ± 5%, 50Hz
- 265/460 V ± 5%, 60Hz
- 254/440 V ± 5%, 60Hz

Other voltages available on request.

Subject to change without notice

Motor Data Sheet

Three-Phase AC Asynchronous Gear Motors 290/500 V (50Hz)

| | | | |
|----------------------------|--------------------------------|-------------|----------------------|
| Pump model | | ZPU 09 | Units |
| Motor manufacturer | | ABM | |
| Motor type | | G80F/D71B-4 | |
| Part No. | | 245-13564-1 | |
| Frequency | f | 50 | [Hz] |
| Nominal power | P | 0.37 | [kW] |
| Nominal speed | n1/n2 | 1370/60 | [min ⁻¹] |
| Rated torque | M | 59 | [Nm] |
| Nominal current | I _N | 1.45 | [A] at 290 V |
| | | 0.85 | [A] at 500V |
| Starting current/ ratio | I _A /I _N | 3.9 | [A] |
| Power factor | cos φ | 0.73 | |
| Efficiency | η | 0.72 | [%] |
| Frame size | | 71 | S |
| Type of construction | | B5 A1/160 | |
| Type of protection | IP | 55 | |
| Insulation class | | F | |
| Weight | | ca. 11 | [kg] |
| Flange | | Ø160 | [mm] |
| Shaft end | | Ø20X50 | [mm] |

The motor can be connected to the following network:
290/500 V ± 10%, 50Hz