

DIMENSIONS

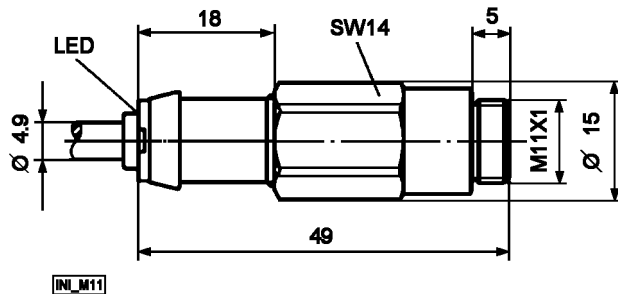

CONNECTION DIAGRAM

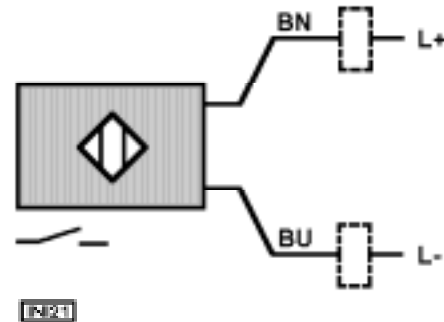

TECHNICAL DATA	
OUTPUT FUNCTION	NO
OPERATING VOLTAGE INCLUDING RESIDUAL RIPPLE [VDC]	10...36
CURRENT CARRYING CAPACITY [mA]	100
VOLTAGE DROP / MAX. LOAD [V]	≤ 4,6
RESIDUAL CURRENT [mA]	≤ 1,0
MINIMUM LOAD CURRENT [mA]	≥ 5,0
OPERATING FREQUENCY [Hz]	typ.800
CONTROL INDICATOR	LED
TEMPERATURE RANGE [°C]	-25...+80
DRIFT OF OPERATING POINT [%]	< ± 10 of s _r
SWITCHING HYSTERESIS [%]	3...15 of s _r
RATED OPERATING DISTANCE (s _n) [mm]	2,0 flush
EFFECTIVE OPERATING DISTANCE (s _r) [%]	s _n ± 10
ADMISSIBLE PRESSURE [bar]	400
TYPE OF PROTECTION	IP67
TIGHTENING TORQUE [Nm]	18
CONNECTION CABLE [m]	5 Cable PU 2x0.5 mm ²
MATERIAL OF HOUSING	42CrMo4 / 1.2275, Surface Fe/Zn 8 F

Function:

The piston detector is utilized to monitor progressive plunger metering devices type SSV. It is a pressure-resistant inductive proximity switch detecting the movements of a metering device piston. It is screwed into the piston hole of the SSV metering device instead of a piston closure plug. Any SSV metering devices can easily be retrofitted. Thus, in conjunction with a control, the piston detector allows the monitoring of a progressive centralized lubrication system