

Data Sheet

Contact Rod AMU-L850 for 200 kg-barrel

Part-No. 980053-E (including magnet assy.)

9.3A-30004-A98

Dimensions

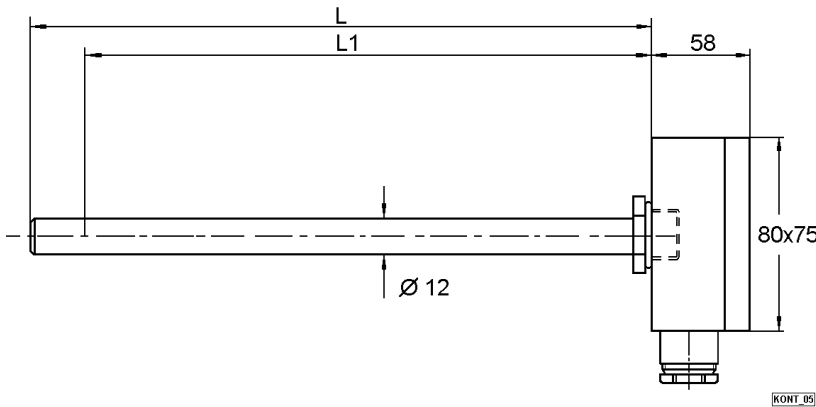

Operation

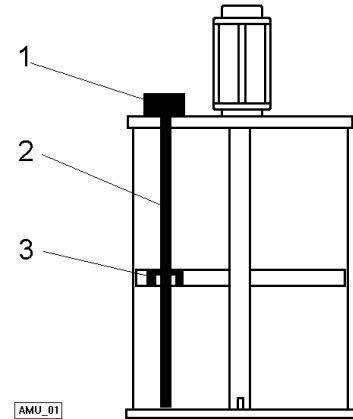

$L = 850$, $L1 = 785$ (switching point)

- 1 : Junction box
- 2 : Guide rod (P-No. 969014-E)
- 3 : Magnet assy. (P-No. 969012-E)

Terminal Connection Diagram

changeover contact

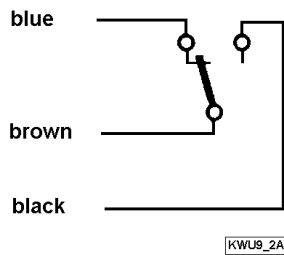

Drilling Pattern on Follower Plate

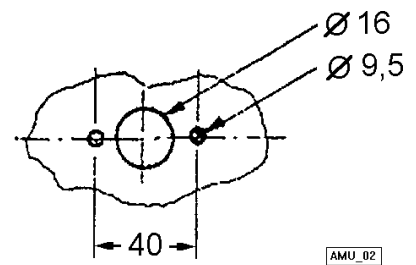

Technical Data

Max. switching voltage	[V AC/DC]	250
Max. switching capacity	[VA/W]	40
Max. switching current	[A]	0,5
Permissible ambient temperature [°C]		-20...+100
Type of protection		IP 65
Material of contact rod		brass
cable entry		PG 11

Operation

The magnet assy. (3) is gliding downwards with the follower plate. The encapsulated gas contact in the guide rod (2) is actuated by the magnet. The actuation is without mechanically contact and absolutely resistant to wear.

Note

The lifetime of the magnetically operated switch highly depends on the conditions of load. As the maximum switching capacity data refer to purely resistive loads, which in practice cannot always be guaranteed, proper contact protective measures must be taken if loads are different.

Contact protective measures

