

Pressure Control for central lubrication pumps and dual-line systems

Pressure control

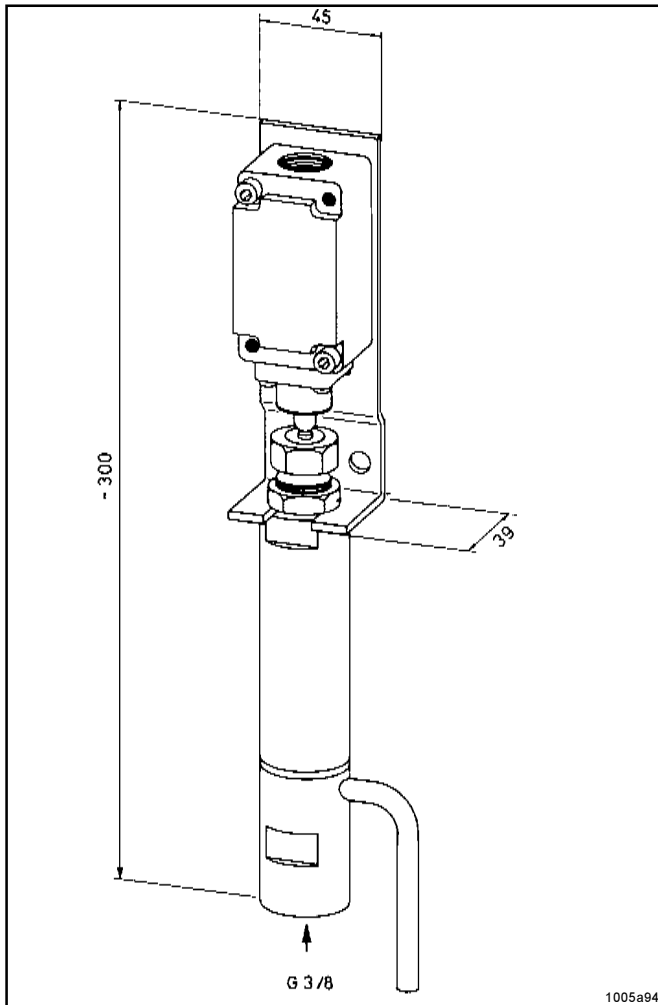

Adjustment of the pressure control:

Before setting the pressure control, disconnect electrical supply to the central lubrication pump.

After having loosened the lock nut SW 27, the spring tension can be adjusted.

The pressure spring is tightened and the maximum pressure is raised by screwing in adjusting screw SW 24. The pressure is reduced by unscrewing the adjusting screw SW 24.

Pressure ranges	Pressure reducer piston and cylinder-Ø	Pressure spring-Ø of wire
from 340 to 600 bar	5 mm	4,0 mm
from 160 to 400 bar	6 mm	4,0 mm
from 160 to 360 bar	7 mm	4,0 mm
* from 130 to 260 bar	8 mm	4,0 mm
from 75 to 170 bar	10mm	4,0 mm
from 50 to 115 bar	12mm	4,0 mm
from 30 to 60 bar	12mm	3,5 mm
from 10 to 40 bar	16mm	3,5 mm
from 0 to 15 bar	16mm	3,0 mm

* Selection for pressure control for dual-line systems, connection thread 3/8" BSP Limit switch
 1 opening and 1 closing contact
 Components:
 Complete as illustrated (pls. indicate diameter of piston when placing an order)

Installation consideration for the client:
 Wiring from limit switch to electric control box.

Subject to modifications

Electro-hydraulic Pressure Switch for Central Lubrication Pumps and Two-Line Centralized Lubrication Systems

Instructions for the adjustment of the pressure control switch

The purpose of the pressure control switch is to de-energize the electrical drive of the lubrication pumps when the preset maximum pressure is reached.

The drawing overleaf shows the arrangement of the pressure control switch used on the lubrication pumps.

The pressure reducers (14), consisting of the piston and piston guide, and the compression springs are selected for the various pressure ranges according to the desired maximum pressure in the pressure lines of the lubrication systems.

The ranges can be read from the following table:

Pressure adjustment range	Pressure reducer Piston diameter	Compression spring Wire diameter	Part-No.
340 bar - 600 bar	5 mm	4 mm	523-31151-1
160 bar - 400 bar	6 mm	4 mm	523-31246-1
160 bar - 360 bar	7 mm	4 mm	523-31130-1
130 bar - 260 bar	8 mm	4 mm	523-31131-1
75 bar - 170 bar	10 mm	4 mm	523-31132-1
50 bar - 115 bar	12 mm	4 mm	523-31134-1
30 bar - 60 bar	12 mm	3,5mm	523-31134-1
10 bar - 40 bar	16 mm	3,5mm	523-31135-1
0 bar - 15 bar	16 mm	3 mm	523-31135-1

Adjustment of the pressure control

Before adjusting the pressure control switch, the electrical current at the lubrication pump must be switched off.

When the lock nut (5) SW 27 has been loosened, the tension of the spring can be adjusted.

By screwing in the adjustment screw (4) SW 24 the compression (7) is tightened and the maximum pressure raised; the reverse process brings about a lowering of the maximum pressure.

Should this adjustment not be sufficient, then the compression spring (7) must be exchanged in accordance with the table.

To this end, the adjustment screw (4) must be loosened until the tension of the spring (7) is released.

The casing of the spring (8) is then unscrewed from the pressure reducer (14) and lifted off; the flat washer (6) and the compression spring (7) are to be removed. A new compression spring (7) can now be inserted, e. g. with wire of 3.5 mm diameter. The grease drain pipe (15) is connected into the pressure reducer (14) and should prevent grease from leaking into the spring casing.

**Electro-hydraulic Pressure Switch for Central Lubrication Pumps and
 Two-Line Centralized Lubrication Systems**

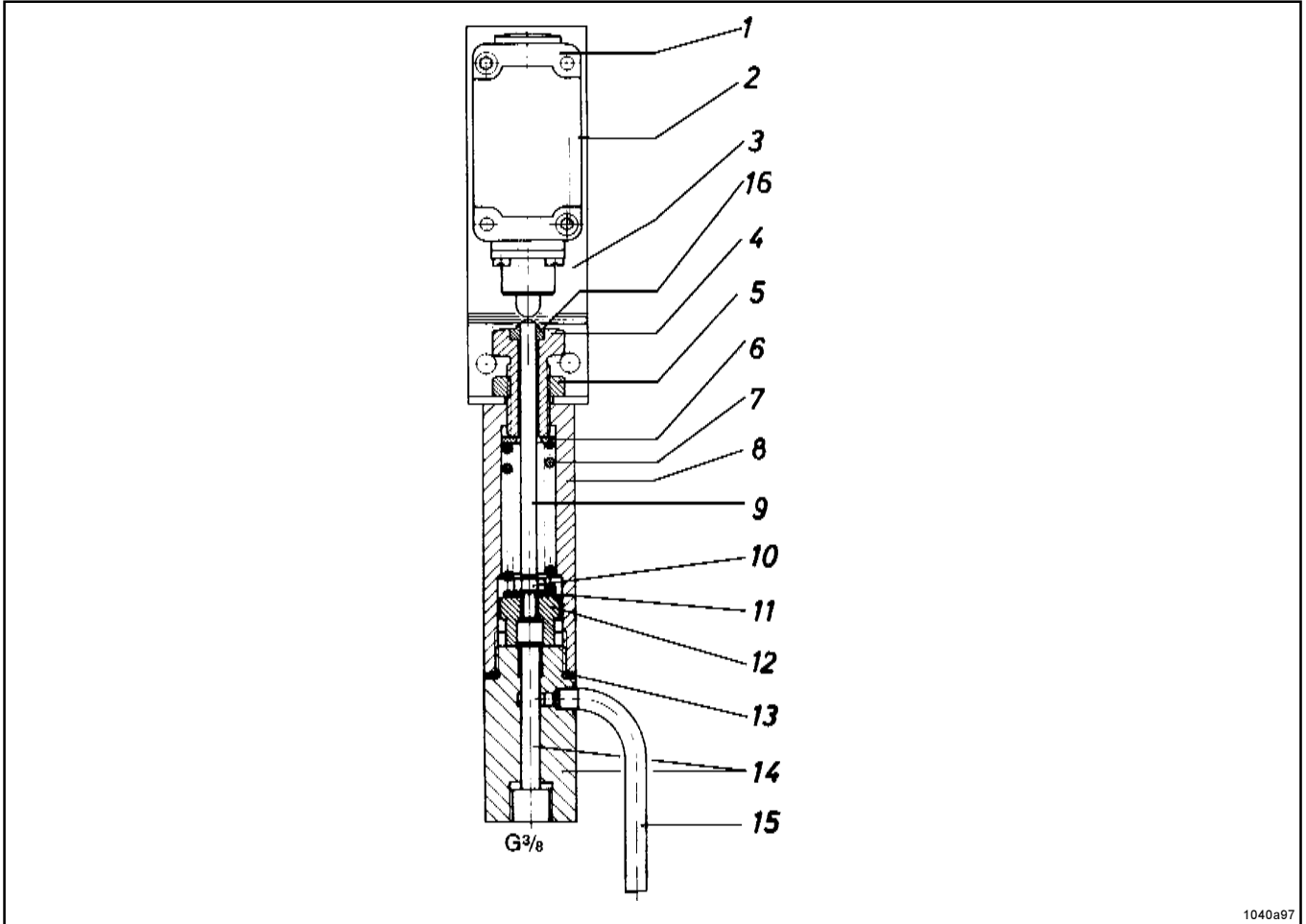

1040a97

Item	Designation	Part-No.
1	Position switch	236-13262-4
2	Hexagon socket head screw M 5 x 40	201-12594-2
	Washer DIA 5,3	209-12146-4
	Hexagon nut M 5	207-12138-2
3	Elbow	307-18875-2
4	Adjusting screw	303-19202-1
5	Hexagon nut G 3/8 Z	207-12143-9
6	Washer DIA10,5	209-12152-8
7	Compression spring DIA 3	300-17221-1
	Compression spring DIA 3,5	300-17222-1
	Compression spring DIA 4	300-17220-1
8	Spring housing	423-21310-1
9	Pin	301-19203-1
10	Hexagon nut M 6	207-12138-3
11	Tooth lock washer J 6, 4 Z	210-12161-3
12	Contact button	423-21311-1
13	Sealing ring	306-17815-1
14	Pressure reducer (see chart on page 2)	
15	Grease drain pipe	423-21312-1
16	Scraper	220-12239-2

Subject to modifications

Limit switch assembly
 632-36501-1

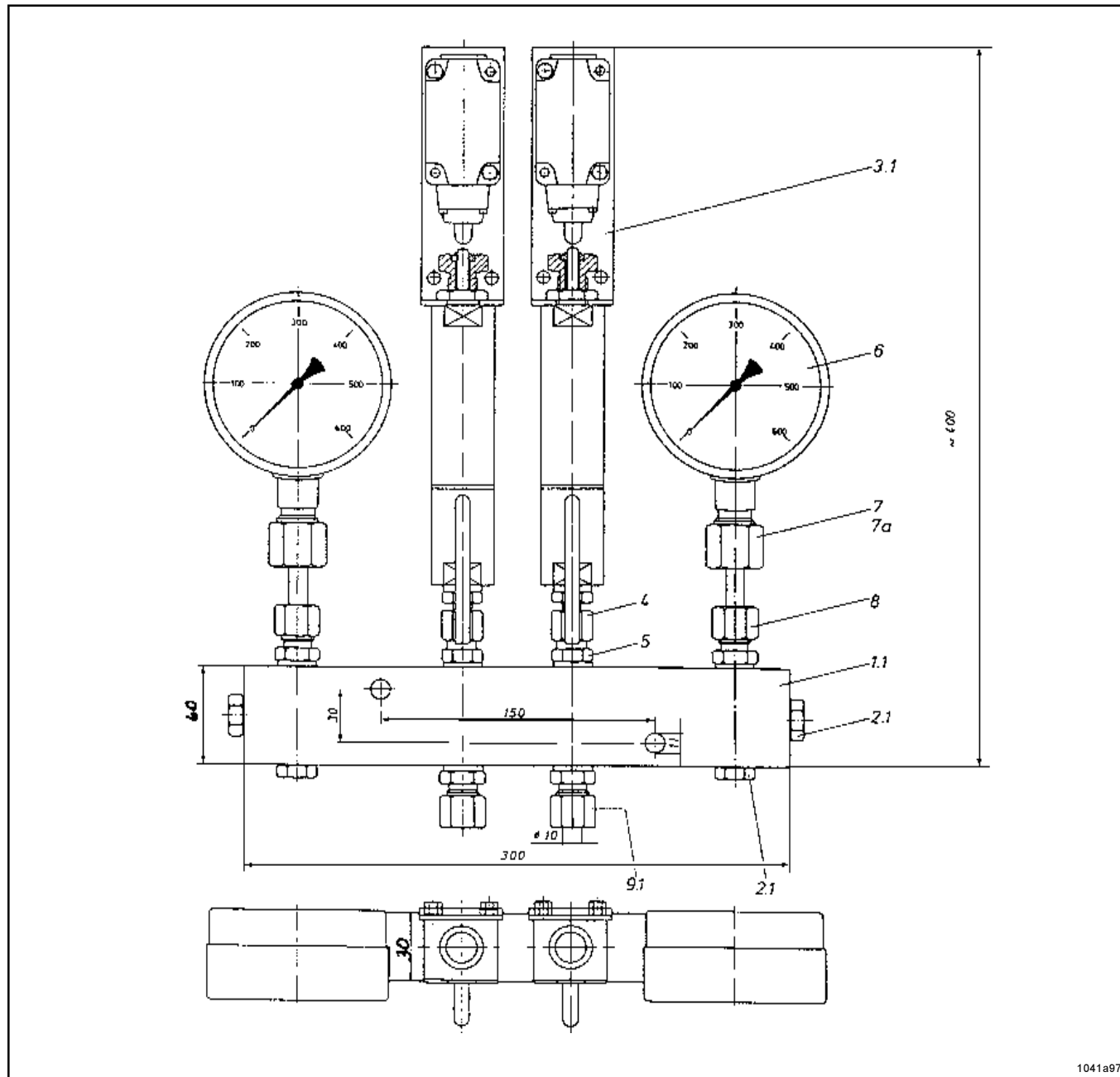

1041a97

Item	Designation	Qty.	Part-No.
1	Housing	1	432-22970-1
2	Closure plug R 3/8" x 10	4	303-17440-1
3	Limit switch	2	623-27177-1
4	EVGE 10 - SG 3/8" A - ED	2	223-13033-4
5	GE 10 - SG 3/8" A	2	223-13016-4
6	Pressure gauge, 0 - 600 bar	2	234-13101-2
7	Adapter	2	304-17573-1
8	GE 10 - SG 1/2" A	2	223-13621-7
9	GE 10 - SG 3/8" A	2	223-13016-4

Subject to modifications