



LINCOLN
INDUSTRIAL

PL-2000

Series B

The Breakthrough in automating manual grease lubrication



Owner's Manual

LINCOLN
INDUSTRIAL

One Lincoln Way
St. Louis, Missouri 63120-1578
(314) 679-4200

Copyright 1997
Printed in U.S.A.

FORM 402825

Index

Lubricator Instructions	Page Number
Description	4
Lubricator Mounting Instructions	5-6
Lubricator Mounting "Template"	15
Installing Grease Lines	6-7
Electrical Wiring	8
Setting the Timer	9
"Override" (manual lube) Fitting	10
Filling the Reservoir	10
Manual Lube Button	10
Remote Monitor Option	11
Disposal Information	12
Troubleshooting Chart	13
Replacement Parts List	14
Specifications, Dimensions & Packing List	Separate Sheet

Description

The Lincoln PL-2000 is a programmable lubrication system that can supply grease to a maximum of 18 fittings. It can dispense NLGI #2 grease at timed intervals from 2 hours to 30 days. Each cycle of the system dispenses .012 in³. of grease per outlet.

The lubricant reservoir is divided by a special diaphragm, with the upper portion of the reservoir precharged for life with nitrogen gas. Filling the reservoir with grease provides the pressure necessary to dispense lubricant to the fittings.

A signal from the system timer opens a solenoid valve and allows lubricant from the reservoir to flow to a divider valve. When all grease fittings have received lubricant, an internal cycle switch turns the system off, completing one lubrication cycle.

The lube timer has a memory. If power is turned off for less than 72 hours, it “remembers” where it stopped, and will restart at the same point when power is restored. (This prevents over-lubrication of the machine if power is switched on and off over short periods of time.) If power is off for more than 72 hours, the timer will begin a lube cycle when power turns on, then start timing toward the previously selected lubrication interval.



Installation Instructions

Use the following recommendations to select a mounting location for the PL-2000 lubricator.

- Keep the feed lines as short as possible.
- Provide access to fill, clean, and monitor the PL-2000.
- Allow adequate room for mounting and connecting feed lines to the PL-2000.
- Installing the PL-2000 with the reservoir on top is preferred, but it may be installed in any orientation without affecting its operation.

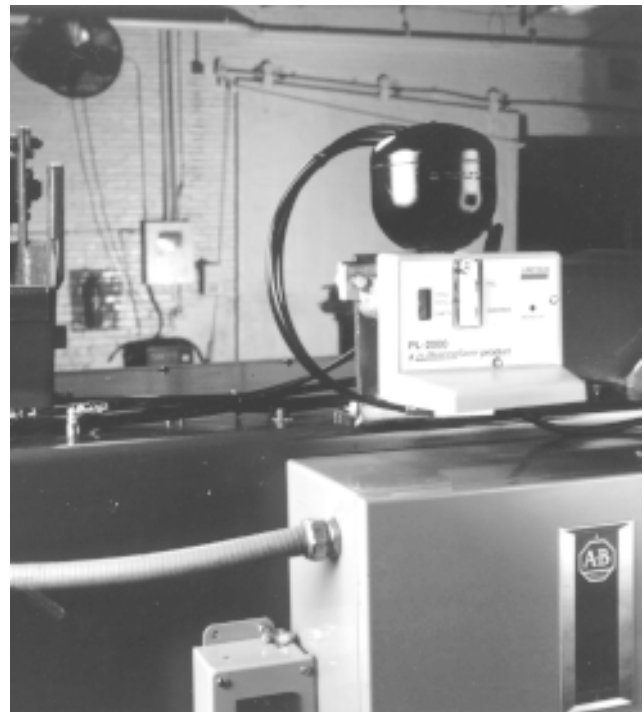

Installation Instructions (cont.)

1) To remove the bezel cover:

Caution: A short ribbon cable runs from the bezel cover to the timer card. Unplug the cable before removing the bezel cover completely, or you may damage the timer card.

- Remove two screws
- Unclasp the hooks at the front of the bezel cover from the body of the PL-2000
- Rotate the cover up towards the reservoir, pulling it slightly away from the body, exposing the ribbon cable to the timer card.
- Slide the timer card out of the body just enough to remove the ribbon cable connector from the timer.
- Completely remove the bezel cover and set it aside.

Note: When reinstalling the bezel cover, be careful not to crimp the ribbon cable between the bezel cover and lubricator body.

2) Determine the mounting location, then:

- The lubricator weighs approximately 20 pounds. Be sure the mounting location will support the weight.
- Drill two 7/16 holes spaced 4-1/2" apart, or
- Use template provided on page 15 to locate holes.
- Fasten the PL-2000 to the machine, using the mounting tabs and 3/8" bolts provided, as shown in photograph at right.



Installation Instructions (cont.)

- 3) Route the feed lines (included with kit) from the PL-2000 to the grease fittings, and cut to length.

Caution: Be sure to keep cut ends square and clean to avoid leaks.

- Keep the lines short as possible. (Feed lines should not exceed 15' at temperatures below 0°F when using NLGI #2 grease.)
- Avoid sharp bends or moving parts of the machine which could damage the tubing.
- If grease fitting is located on a moving part, leave a loop in the feed line large enough to accommodate the movement.



- 4) Outlets can be combined to increase the amount of grease that goes to a single fitting. To do this, simply replace the tubing adapter with a closure plug and gasket in one or more outlets. Lubricant from a plugged outlet is redirected to the next outlet on the same side of the divider valve—on a 12 outlet system in descending numerical order and on an 18 outlet system in ascending numerical order. Example: Plugging outlets 5 & 3 will triple the amount of grease at outlet 1 (as shown on 12 outlet system at right).

- Closure plugs and gaskets are provided with this kit.

Important Note:

Do not plug outlets 1 and 2 on 12 point systems. Do not plug outlets 17 and 18 on 18 point systems. Plugging these outlets will stop the flow of grease from all outlets.

- Connect the feed lines to the PL-2000 by pushing the end of each tube firmly into the Quickline fittings at the outlets of the divider valve, as far as they will go.

Important Note:

Never feed grease from one outlet to more than one fitting. Grease flow to more than one fitting will not be positively controlled and will result in under or over lubrication.

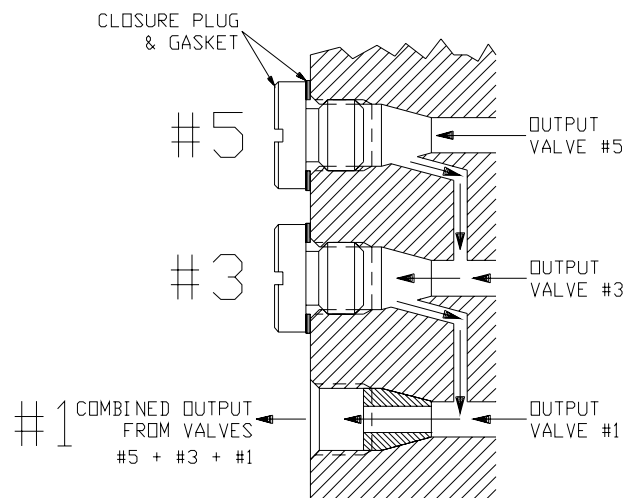

Installation Instructions (cont.)

- 5) Secure feed lines to the machine using clamps or straps.
- 6) Connect feed lines directly to existing grease fittings using the Zerk-Lock™ fittings included with the kit. The Zerk-Lock fitting consists of the Zerk-Lock body, insert, and a Quickline™ fitting.

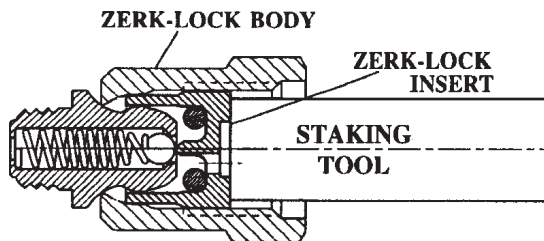

- Place the Zerk-Lock body over the grease fitting and place the staking tool firmly against the Zerk-Lock insert. (Staking tool included in the kit.) Strike the tool sharply with a hammer until the Zerk-Lock insert partially crimps onto the grease fitting.

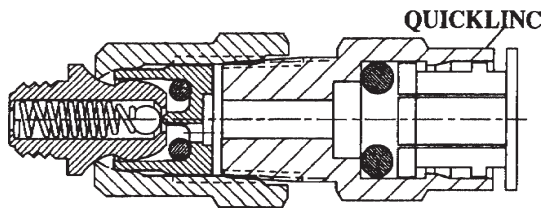

- Screw the Quickline fitting into the Zerk-Lock body and tighten until parts resist further tightening, (about 1-1/2 turns). **Note:** Quickline hex is 1/2". Zerk-Lock body hex is 12mm.

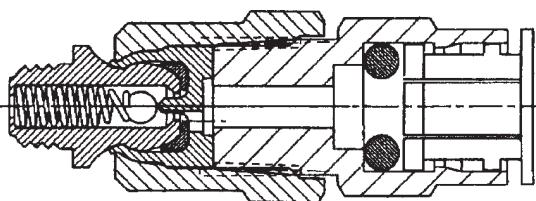

- Move the Zerk-Lock and tube fitting from side to side on the grease fitting to insure the Zerk-Lock is firmly seated.
- Push the end of the feed line firmly into the Quickline fitting until it is fully seated in the body.

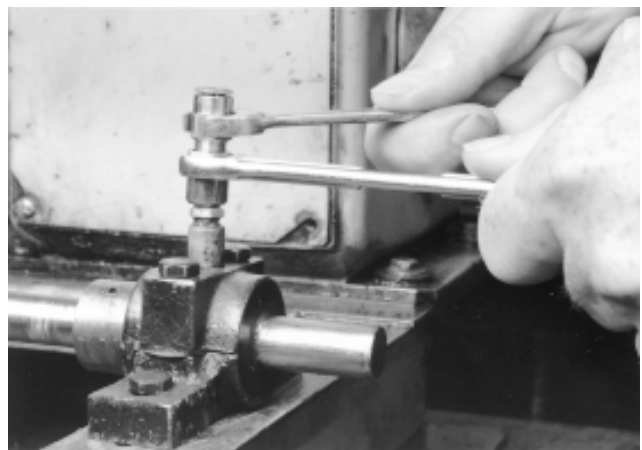
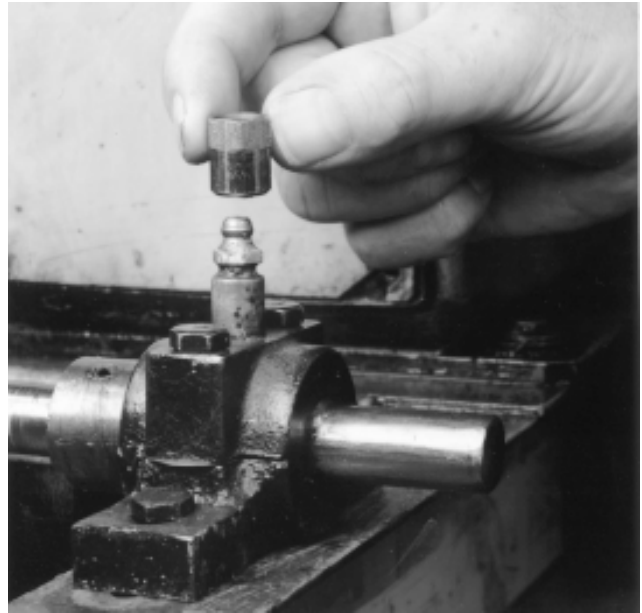

Installation Instructions (cont.)

- 7) **Do not turn on the power to the timer yet.** Run electrical power to the PL-2000. Refer to the name plate on the right side of the PL-2000 unit for the electrical requirements of the model you have. All wiring should conform to the National Electric Code and any local ordinances and codes.

Direct Current (DC) operated PL-2000 (See illustration below.)

- Connect the **RED** wire from the PL-2000 to the **POSITIVE** terminal of the DC power source.
- Connect the **BLACK** wire to the **NEGATIVE** terminal of the DC power source.

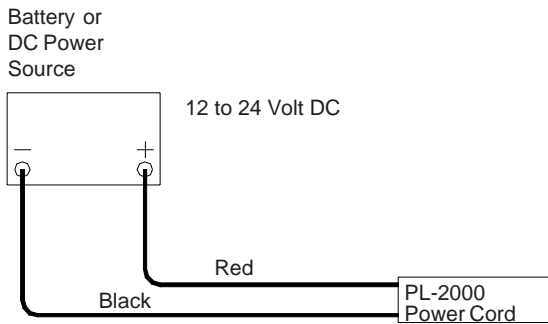

Alternating Current (AC) operated PL-2000

120 Volt (See illustration below)

- Connect the **GREEN** wire to the equipment **GROUNDING** terminal of the power source.
- Connect the **WHITE** wire to the **NEUTRAL** terminal of the power source.
- Connect the **BLACK** wire to the **HOT or L1** terminal of the power source.

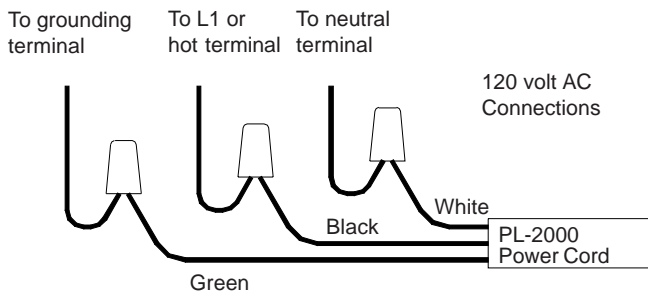

Alternating Current (AC) operated PL-2000

230 Volt (for North American use):

- Connect the **GREEN/YELLOW** wire to the equipment **GROUNDING** terminal of the power source.
- Connect the **BLUE** wire to the **HOT OR UN-GROUNDED** terminal of the power source.
- Connect the **BROWN** wire to the **HOT or UNGROUNDED** terminal of the power source.

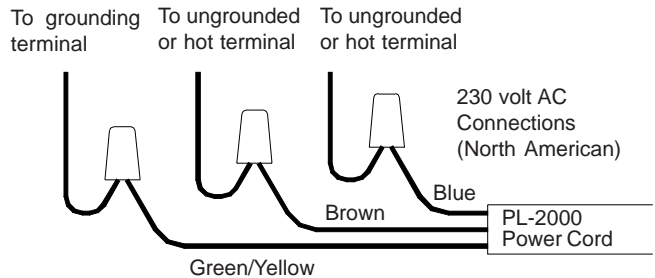

230 Volt (for continental European use):

Note: The supplied cord meets European CEE color coding standards.

- Connect the **GREEN/YELLOW** wire to the equipment **GROUNDING** terminal of the power source.
- Connect the **BLUE** wire to the **NEUTRAL** terminal of the power source.
- Connect the **BROWN** wire to the **HOT or L1** terminal of the power source.

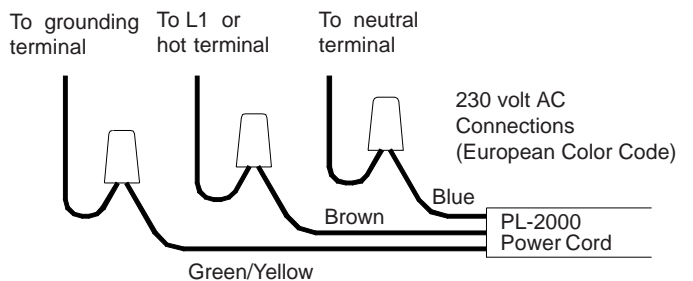

Setting the Cycle Time

WARNING

 Turn off and lock out power to the PL-2000 before opening the enclosure.

- 1) Remove the bezel cover from the front of the PL-2000.

Caution: A short ribbon cable runs from the bezel cover to the timer card. Unplug the cable before removing the bezel cover completely, or you may damage the timer card.

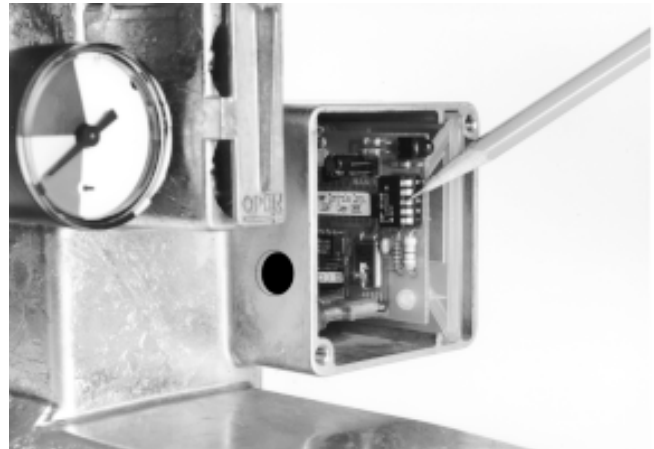

- 2) Timer switches are accessible at the front side of the circuit card.
- 3) Based on the machine lubrication requirements, set the desired cycle times on switches #1 through #5. Per the following illustrations.

- 4) Before reinstalling the bezel cover, push the ribbon cable connector over the two pins on the timer card (just behind the switches). Then carefully slide the timer card assembly back into the enclosure, checking to insure that all connecting wires are still plugged into the timer card. Replace the bezel cover.

Note: When reinstalling the bezel cover, be careful not to crimp the ribbon cable between the bezel cover and lubricator body.

Two hour time increments

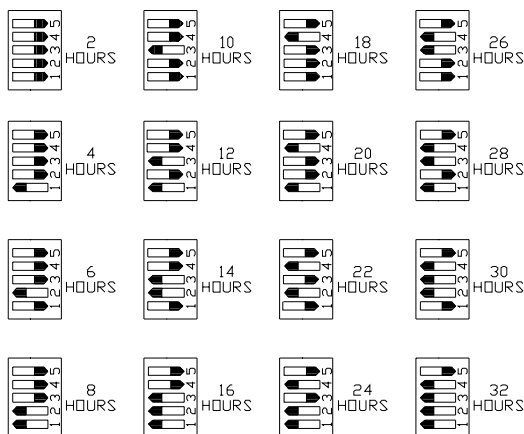

Two day (48 hour) time increments

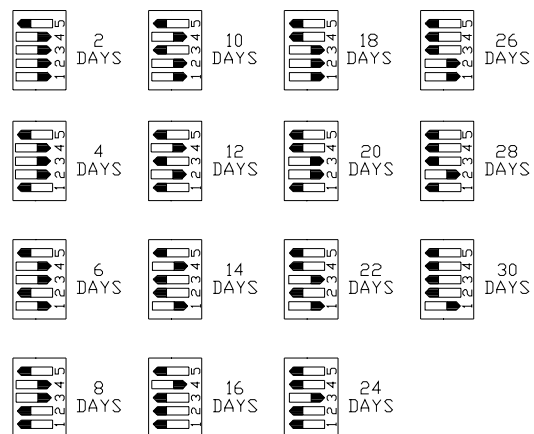

Testing Cycle

Timer test function:

Placing timer switches #1 through #5 as shown places the timer in the test mode. The test mode will provide 20 seconds between lube cycles.

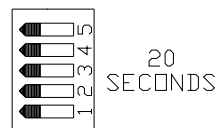

Initial Start-up & Operation

Both the **FILL** and **OVERRIDE** fittings are behind a protective cover which swings open in a counter clockwise direction.

As with all lubrication systems, lubricant is to be clean and free of foreign material and grit. Filter if necessary.

1) Purge system:

Pump grease into the **OVERRIDE** fitting until you see lubricant flowing at all the bearing seals.

- Grease pumped through the override fitting bypasses the timer controlled valve and reservoir and goes directly through the divider valve block to the grease fittings.

2) Fill the reservoir:

- Pump grease into the **FILL** fitting. The reservoir is full when the needle on the **LEVEL INDICATOR** reaches the top of the green **READY** area. **DO NOT OVER FILL.** The PL-2000 is equipped with a safety relief valve which will discharge lubricant if the reservoir is overfilled.

3) To apply power for the first time:

- Turn on power to the unit.
- The **MONITOR** light will come on if power has been off more than 72 hours, indicating that a lube cycle is taking place. It will turn off when the lubrication cycle is complete.
- Lubricant will begin to flow to the grease fittings.

4) Monitor light:

- Will stay on until the lubrication cycle is completed.
- Will stay on longer as the lubricant level in the reservoir decreases. (This is normal.)

5) Manual Lube button:

- Will initiate a lube cycle when pushed.
- Is used as a check to see if the system is operating properly
- Is used when you want to lubricate between preset lube cycles.

Note: Pushing the manual lube button resets the timer card, causing it to wait the full preset interval before initiating the next automatic lube cycle.



Remote Monitor Option

- Two terminals connecting to dry relay contacts on the timer circuit card can be used to send a remote indication of a lube cycle.
- The relay contacts close with each lube event and open on completion of the event.
- Contacts are UL/CSA rated for 5A @125 VAC, 1/10 HP, 5A @30 VDC.
- Suggested use: Warning light or sound device, signal for machine controller, etc.
- To access the relay contacts, a hole must be drilled into the side of the enclosure. Hole will be used to run wires from relay contacts to warning device.

WARNING

Disconnect power before removing timer board. Then drill into enclosure. See diagram below for hole specifications.

- Use appropriate cord connector, such as Kellems part number HJ1006G or equivalent. If necessary, take measures to seal the cord and cord connector against moisture.

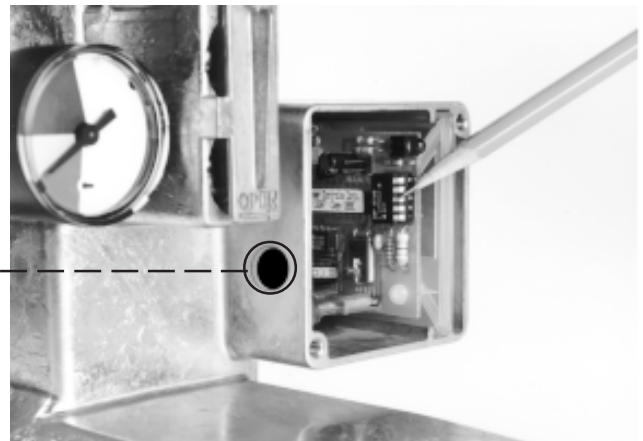
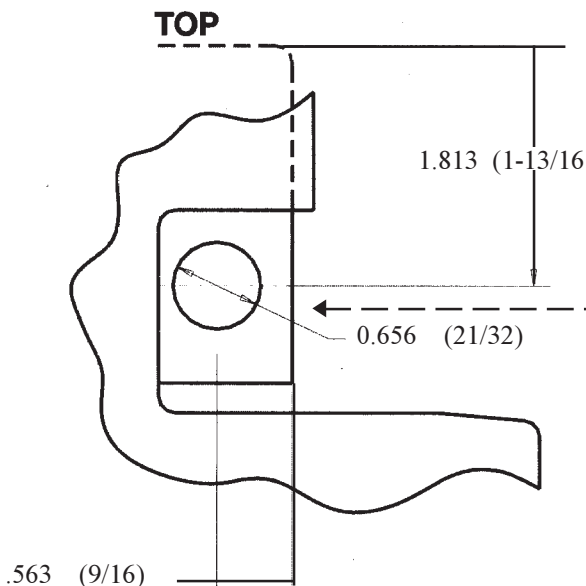
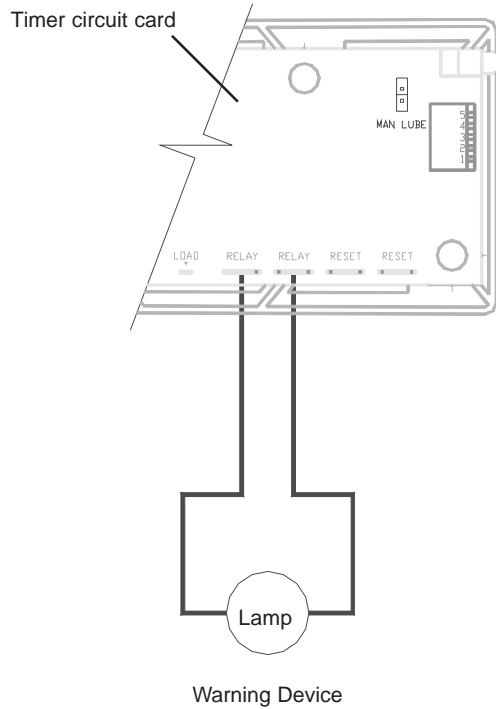

Special instructions for handling or removal of PL-2000 from service:

IMPORTANT: Vent pressure from the lubricant reservoir before handling the unit in any way, and before removing it from its installed position.

Venting lube pressure from reservoir:

- KEEP EYES AND HANDS AWAY FROM THE VENT PORT. See photos at right.
- DO NOT REMOVE VENT SCREW COMPLETELY FROM BODY.
- DO NOT TURN VENT SCREW MORE THAN ONE TURN COUNTERCLOCKWISE.
- OPEN SLOWLY.
- Open VENT VALVE on the top left side of the unit by turning counterclockwise, one turn or less, with a 7/32" Allen Wrench.
- Leave vent screw open until all lubricant flow stops.

Removal from service:

If the PL-2000 unit is to be taken out of service, **do not throw in the trash.** The grease reservoir is charged for life and all units are to be returned to Lincoln or an Authorized Lincoln Distributor for proper disposal. The units are to be vented prior to removal from the machine. (See **Venting Lube Pressure** above.)

IMPORTANT: For disposal instructions, contact Lincoln Technical Services Dept. at 1-314-679-4200, ext. 782.

Vent Screw Location

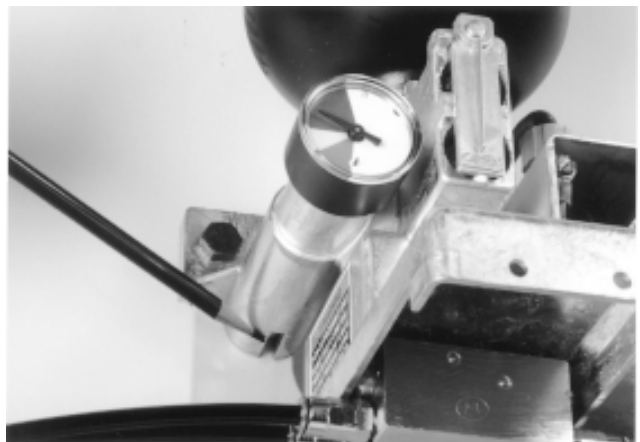
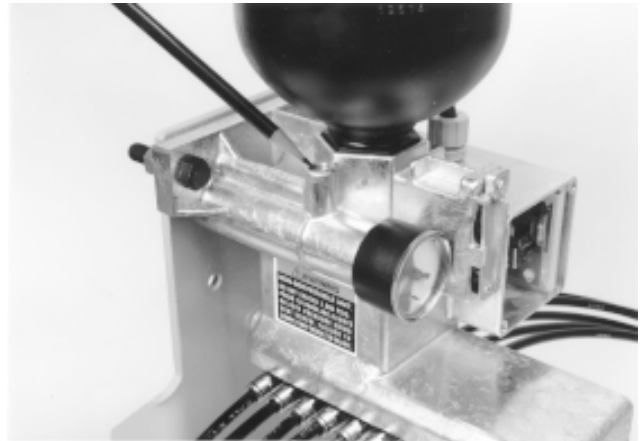

Vent Port Location where grease will discharge when vent screw is opened.

Trouble Shooting Chart

Symptom	Possible Cause	Solution
Monitor Light stays on. No apparent lubricant delivery to lube points.	Reservoir empty	Fill reservoir
	Reservoir overfilled	Bleed off some lubricant from reservoir using vent valve.
	Wire connections to timer are loose or incorrectly wired.	Check that timer connections are tight and correct.
	Blocked feed line.	Loosen fittings at divider valve outlets until lubricant, under pressure, emerges from one outlet. This indicates the blocked feed line. Trace to determine cause of blockage and resolve problem. Check for kinks or collapsed feed line.
	Low voltage or incorrect current to PL-2000.	Check that the power source supplying power to the PL-2000 matches the name plate requirements.
	The PL-2000 may be in the process of a lube cycle.	Wait until the lube cycle is completed. Check the reservoir level gage, lubricant level may be getting low. Refill reservoir to correct level.
	Closure plug may be installed in wrong outlet port of divider valve. (See important note on page 6.)	Remove closure plug and install in correct outlet port. (See page 6.)
Monitor light does not turn on. No apparent lubricant delivery to lube points.	Low voltage, incorrect current or no power supplied to PL-2000.	Check that the power source supplying power to the PL-2000 matches the name plate requirements, and it is turned on.
	PL-2000 may be between lube cycles.	Press manual lube button, monitor light should light and lubricant should be delivered to bearing. Check time switches for correct settings.
Monitor light does not turn on. No apparent lubricant delivery to lube points. Pressing Manual Lube button has no effect.	Timer failure.	Replace timer assembly.
	Incorrect or no power supplied to PL-2000.	Check that the power source supplying power to the PL-2000 matches the name plate requirements and it is turned on.
Monitor light does not turn on. Lube points appear to be getting normal amount of lubricant.	Timer failure.	Replace timer assembly.
Lube points are over lubricated, otherwise PL-2000 appears to operate normally.	Time settings incorrect for application and need to be revised.	Confirm proper time settings. Revise time settings as required.
	Failure of lubrication unit.	Obtain service or replace.
Lube points are over lubricated. Reservoir is empty. Upon refilling reservoir, PL-2000 continues to deliver lubricant to lube point after monitor light turns off.	Dirt or foreign matter in lubricant supply.	Using clean lubricant, free of dirt and grit, pump lubricant into Override fitting. Check for proper operation. Refill reservoir with clean lubricant.

Replacement Parts

Part Number	Std. Pkg. Qty.	Description
241054	1	Nylon cable ties (7") (100 pcs.)
241055	1	Nylon cable ties (7") (50 pcs.)
241056	1	Nylon cable ties (7") (25 pcs.)
244047	1	Quicklinc Fitting (for Zerk-Lock)
244883	1	Quicklinc fitting (lubricator outlet)
247340	1	Zerk-Lock™ fitting
250687	1	1/4" (.250) OD X .050" Wall Nylon Tubing (50')
250707	1	DC timer ass'y.
250719	1	AC timer ass'y. (120 VAC)
251240	1	AC timer ass'y (230 VAC)
251254	1	Bezel cover ass'y.
209121582	1	Gasket (closure plug)
303174992	1	Closure plug

Remove template along perforation.

2X $\frac{7}{16}$ "
[10.31MM]
HOLES

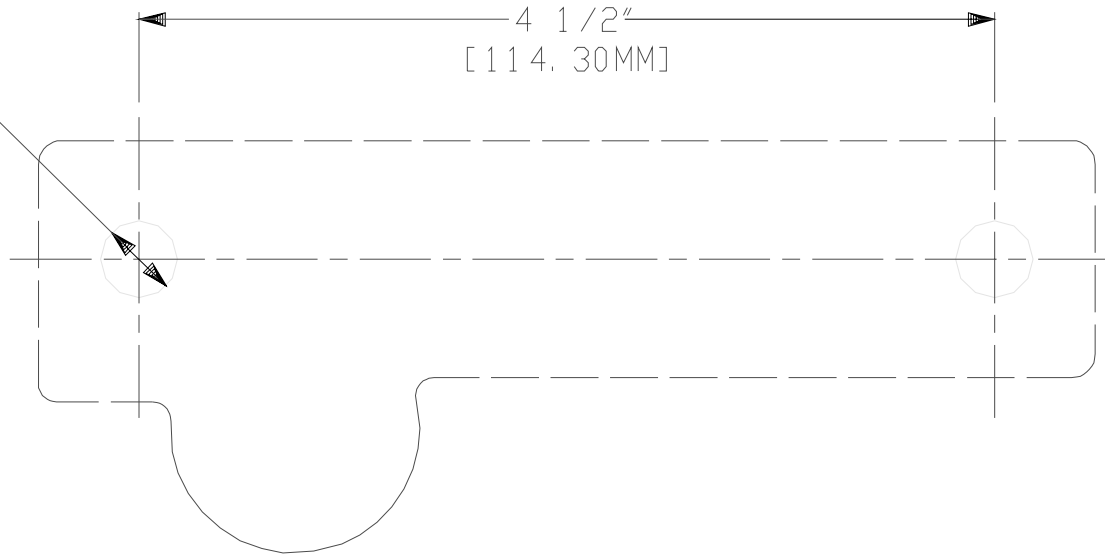

MOUNTING HOLE TEMPLATE
MOUNTING SURFACE MUST SUPPORT
AREAS INDICATED BY BROKEN LINE

POSITION TEMPLATE AND DRILL
TWO HOLES AS INDICATED.

