

OWNER/OPERATOR MANUAL

PLANETARY GEAR DRIVE --- PRESET --- TOTALIZING --- 1000 PSI MAX. OPERATING PRESSURE

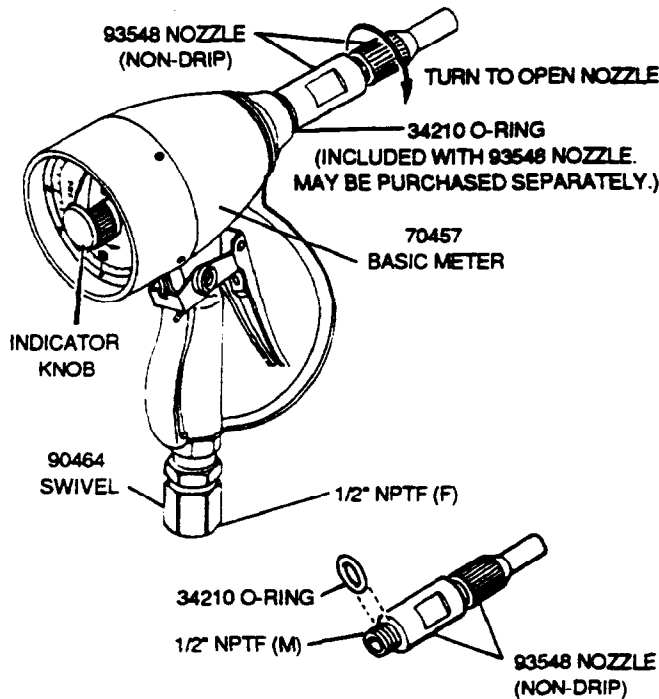

MODEL	USE	MEASURE
3867	Oil	60 - Quarts Total

OPERATION

Turn preset indicator knob counterclockwise to the quantity required for the application.

NOTE: Indicator knob can only be turned in a counterclockwise direction when setting the quantity.

Squeeze the trigger handle to dispense the desired amount of fluid. The indicator knob will rotate clockwise and the control valve will shut off after the preset amount has been dispensed.

If oil continues to leak from nozzle tip after the trigger is released, oil is bypassing Valve Seat Assembly (Item 28). Replace Valve Seat Assembly if worn or damaged. Check Non-Drip Nozzle (93548).

To remove Valve Seat Assembly, disconnect delivery hose and Swivel (90464) from Control Valve. Unscrew Adapter (32) and remove parts.

Oil may be bypassing O-Ring (34210) located between Non-Drip Nozzle (93548) and Cap (Item 36). Replace O-Ring if worn or damaged.

IMPORTANT

THIS UNIT IS NOT FOR RESALE OF PRODUCT AND IS NOT SUBJECT TO RESALE TOLERANCES.

NEW METERING SYSTEMS MUST BE PURGED PRIOR TO INSTALLATION OF METERING CONTROL VALVE TO CLEAN SYSTEM OF CONTAMINATES.

BASIC METER (TOTALIZING)

ITEM	PART NO.	QUAN	DESCRIPTION	ITEM	PART NO.	QUAN	DESCRIPTION
1	242911▲	1	Shroud protector	20	236400	1	Pin lock pawl
2	68410-12	1	Shroud	21	68410-2	2	Screw
3	66871-5	4	Shroud screw	22	70457-8	2	Washer
4	242913	1	Knob assembly	23	68410-4	2	Quad ring
5	69303	1	Dial assembly	24	69304-2	1	Cam
6	66871-3	2	Clutch spring	25	69304-4	1	Trigger assembly
7	66871-4	2	Clutch roller	26	69304-21	1	Hand guard
8	69304-9	1	Compound gear assembly	27	68410-6	1	Valve sleeve assembly
9	69304-10	1	Preset knob drive cam	28	68410-25	1	Valve seat assembly
10	66871-157	1	Worm assembly	29	69304-3	1	Spring
11	50541	1	Set screw	30	68410-27	1	Screen
12	69304-23	1	Washer	31	243176	1	O-ring
13	70457-7	4	Screw	32	243175	1	Adapter
14	68602-8	1	Register assembly	33	66871-111	1	Upper driving pawl gear assembly
15	69304-14	1	E-ring	34	68410-15	1	Chamber and piston assembly
16	69304-5	1	Lock bar	35	66871-12	1	O-ring
17	69304-13	1	Lock pawl	36	68410-14	1	Cap
18	69304-12	1	Lock pawl spring				
19	237388	1	Packing kit				

▲ May be purchased separately.



CAUTION

DO NOT TURN POINTER IN A CLOCKWISE DIRECTION AS THIS WILL DAMAGE METER.

The pointer can only be returned to the zero stop in a counterclockwise direction after delivery.

**DIAL GRADUATION ONE QUART.
TOTALS IN GALLONS.**

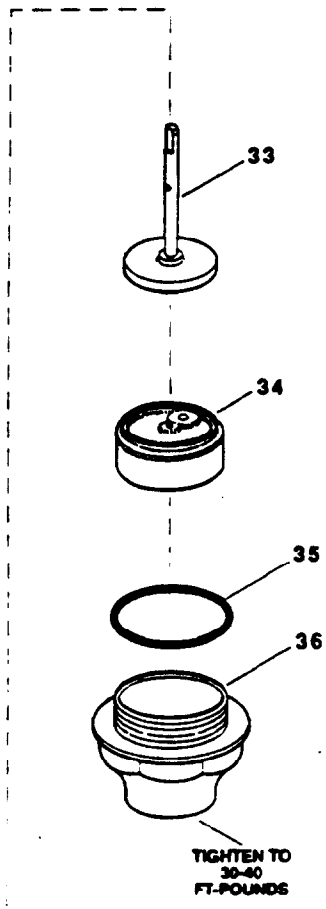
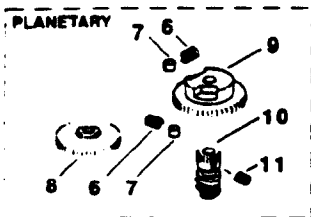
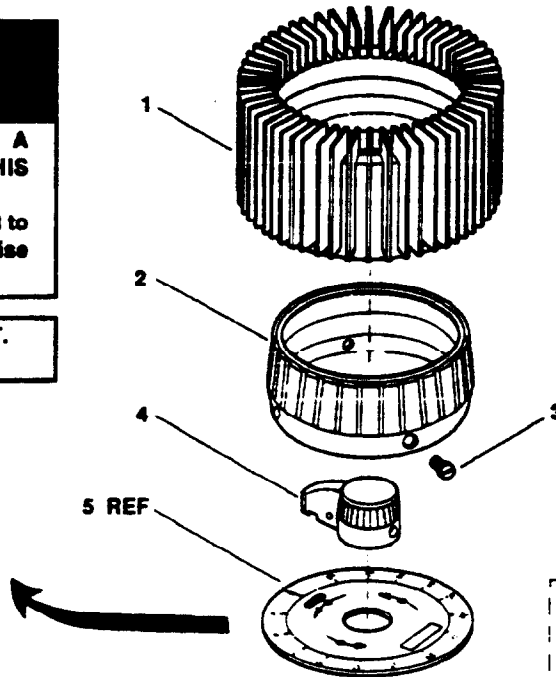
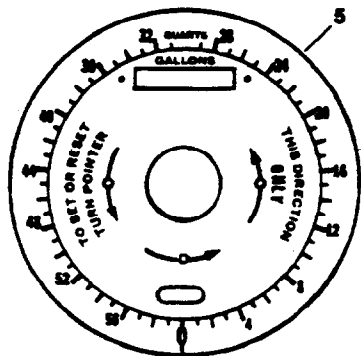

TIGHTEN TO 20 FT-POUNDS MAX.

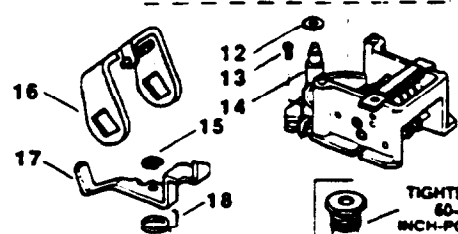
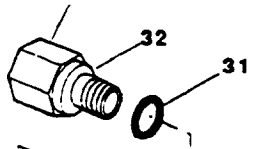

TIGHTEN TO 60-80 INCH-POUNDS

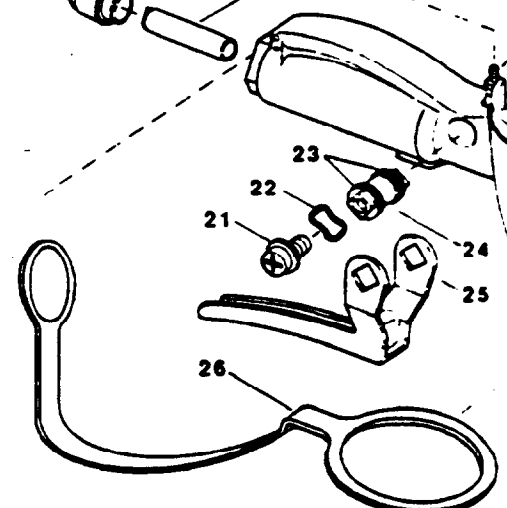
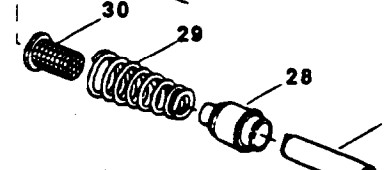
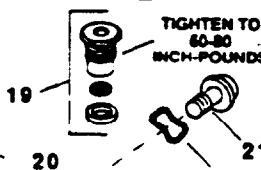

TIGHTEN TO 30-40 FT-POUNDS

RETAIN THIS INFORMATION FOR FUTURE REFERENCE.

When ordering replacement parts, list: part number, description, model number and series letter. Contact Lincoln Customer Service, One Lincoln Way, St. Louis, MO 63120-1578, (314) 679-4300 for your nearest authorized service center.