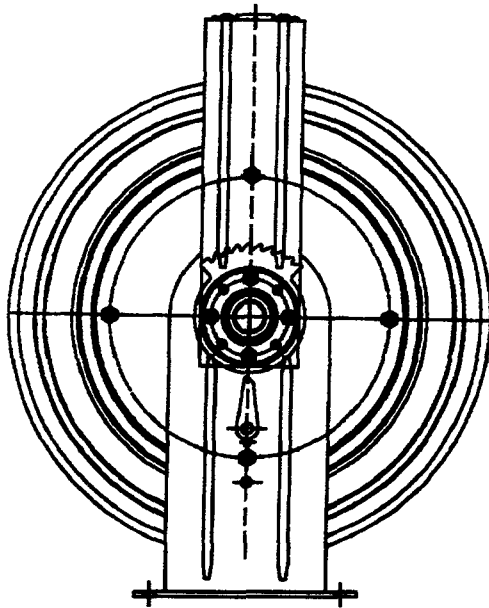

OWNER/OPERATOR MANUAL**SPECIFICATIONS**

Maximum working pressure	200 p.s.i.
Material Inlet	1/2" NPT (Female)
Material outlet	3/8" NPT (Female)
Sheave width	4-1/2"
Sheave diameter	19-1/2"
Drum diameter	12-5/8"
Overall width	6-5/8"
Overall height	23-3/4"
Overall depth	21-5/8"

Maximum hose capacities (Including hang down):

1/4" I.D. Air/water hose	50 ft.
3/8" I.D. Air/water hose	50 ft.

NOTE: Exceeding these capacities voids warranty.
Refer to DELIVERY HOSE INSTALLATION
for proper hose to reel assembly.

DESCRIPTION

Model 6L00 Lubreel is designed for air or water hose storage wherever longer length delivery hose is required. The reel can be installed as a single unit or in multiple configurations. **This reel is not recommended for off-road use.**

Reel features include a reel latch that automatically locks at desired positions as the hose is extended and releases with a short pull on the hose.

OWNER/OPERATOR RESPONSIBILITY

It is the owner/operator responsibility to properly use and maintain this equipment.

The instructions and warnings contained in this manual shall be read and understood by the owner/operator prior to operating this equipment.

If an owner/operator does not understand English, the contents of this

manual shall be explained in the owner/operator native language to assure the owner/operator comprehends.

It is the owner/operator responsibility to maintain the legibility of all warning and instruction labels.

The owner/operator shall retain this manual for future reference to important warnings, operating and maintenance instructions.

WARNING

FAILURE TO HEED THE FOLLOWING WARNINGS INCLUDING MISUSE, OVER PRESSURIZING, MODIFYING PARTS, USING INCOMPATIBLE CHEMICALS AND FLUIDS, OR USING WORN OR DAMAGED PARTS, MAY RESULT IN EQUIPMENT DAMAGE AND/OR SERIOUS PERSONAL INJURY, FIRE, EXPLOSION, OR PROPERTY DAMAGE.

- Do not exceed the stated maximum working pressure of the reel or of the lowest rated component in your system.
- Do not alter or modify any part of this equipment.
- Do not operate this equipment with combustible gas.
- Do not attempt to repair or disassemble the equipment while the system is pressurized.
- Make sure all fluid connections are securely tightened before using this equipment.
- Always read and follow the fluid manufacturer's recommendations regarding fluid compatibility, and the use of protective clothing and equipment.
- Check all equipment regularly and repair or replace worn or damaged parts immediately.
- Never point the dispensing valve at any part of the body or at another person.
- Never try to stop or deflect material from dispensing valve or leading connection or component with your hand or body.
- Always check equipment for proper operation before each use, making sure safety devices are in place and operating properly.
- Always follow the pressure relief procedure after shutting off the pump, when checking or servicing any part of the system, and when installing, cleaning or changing any part of the system.

ASSEMBLY

Assemble reel as follows. Refer to SERVICE PARTS for part numbers and location.

1. SUBASSEMBLY NO. 1

- A. Assemble pawl pin (247356) onto support assembly (247350) and secure with nut (51085).
- B. Assemble pawl spring (237695) to pawl (237683).
- C. Assemble items in step (B) to pawl pin (247356) and secure with washer (247357) and retaining ring (66316).
- D. Assemble axle (247354) into bushing on support assembly (247350) and secure with set screw (229623).
- E. Assemble one retaining ring (247355) to the groove in axle (247354) adjacent to bushing on the support assembly (247350).

2. SUBASSEMBLY NO. 2

- A. Assemble latch hub assembly (247361) and three latch plates (247365) to spring cover assembly (247358) and secure with three hex nuts (51010).
- B. Assemble four studs (248370) to spring cover assembly (247358) and secure with four (51042) hex jamnuts.

3. SUBASSEMBLY NO. 3

- A. Apply pipe sealant to threads of adapter union (247590), reducing bushing (67069) and assemble to swivel hub (247374) and tighten securely. Refer to SERVICE PARTS for proper orientation of assembly after tightening.
- B. Assemble items in step (A) to sheave assembly (247372) and secure with three hex nuts (51010).

4. FINAL ASSEMBLY

- A. Assemble Subassembly No. 2 to axle (247354) and secure with one retaining ring (247355) by installing it in the groove of axle (247354).
- B. Lay the assembly in Step (A) down on its back with the axle extending forward.
- C. Assemble arbor key (247368) onto the flat of axle (247354).
- D. Assemble arbor (247369) on axle (247354) and over the arbor key (247368).
- E. Assemble one O-ring (247371) into each of the two grooves in axle (247354) and lubricate with grease.



CAUTION

Make sure wind direction is correct for proper orientation of arbor.

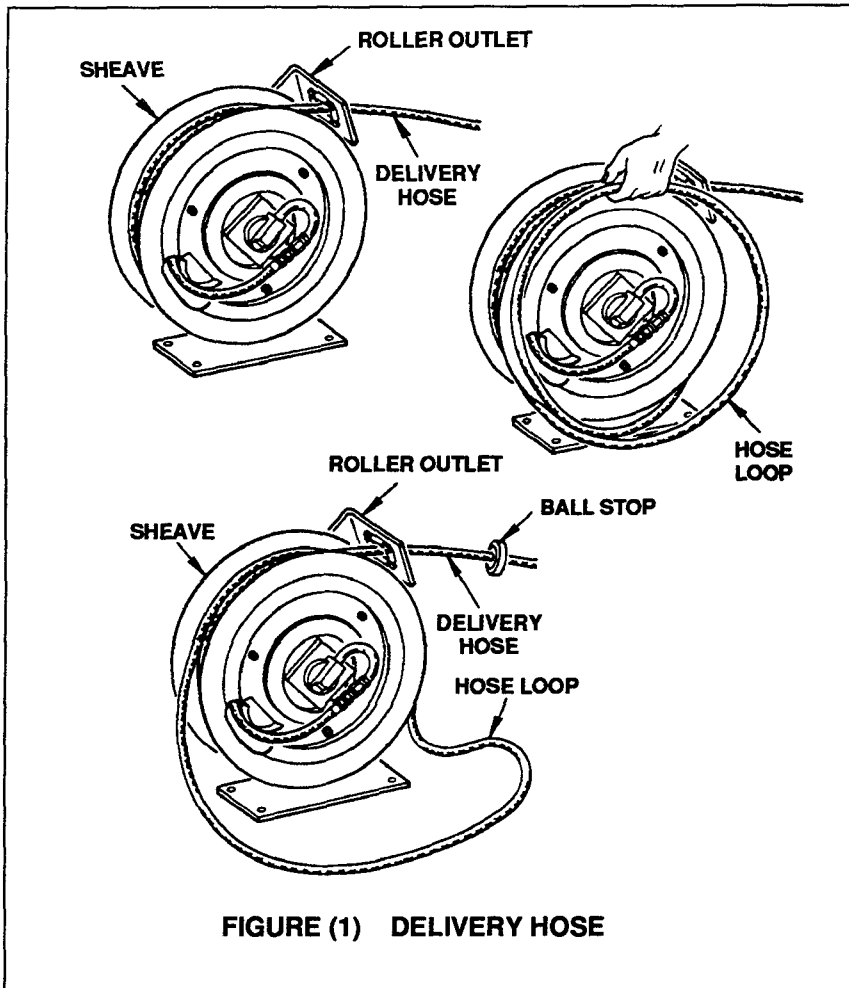

FIGURE (1) DELIVERY HOSE

- F. Assemble one power spring (57083) by sliding outer loop of spring over stud (248370). Assemble over the stud that is offset from the other three. Seat inner loop of spring in arbor.



CAUTION

Make sure wind direction is correct for proper orientation of arbor.

- G. Align holes in Subassembly No. 3 with the four sets of studs (248370). Assemble by sliding onto axle (247354) and secure with four hex jamnuts (51042).
- H. Assemble hose clamp (247136) in hole of sheave assembly (247372) and secure with screw (50302-1) and hex nut (51010).
- I. Assemble roller arm assembly (247375) to studs on support assembly (247350) and secure with four hex nuts (51022).

INSTALLATION

DELIVERY HOSE INSTALLATION (MAXIMUM SPRING TENSION)

For smoother operation during retraction and to increase hose life, "detaic" hose by wiping entire hose length with a light lubricating oil before installing on reel.

Use teflon tape on threads to prevent leaks. See Figure (1). Insert hose end through roller outlet and secure to swivel adapter (68601).



CAUTION

To prevent damaging hose connections and/or components when pulling hose from reel, pull on the hose itself and not on the control valve or swivel. Do not pull or jerk on the hose when fully withdrawn from the reel.

From open side of reel, loop entire length of hose onto reel in a clockwise direction. Pull hose out through roller outlet to wind

power spring. When hose is completely extended, latch reel to prevent it from unwinding.

Continue to add loops of hose and pull out hose until power spring winds tight.

IMPORTANT INSTRUCTIONS

Perform the following instructions as stated to correctly set the power spring for maximum tension.

Allow reel to retract two full revolutions and latch reel. Carefully unloop remaining hose from reel.



CAUTION

To avoid damaging reel components, always make sure hose clamp is properly installed.

Position hose clamp so that approximately 1/2 loop of hose remains on reel and latching does not occur when hose is fully extended.

While holding hose, allow reel to retract hose until desired height from floor is obtained, then latch reel.

Slide ball stop over free end of hose and position slightly below roller outlet. Tighten screws to secure ball stop to hose.

Power spring is now set to maximum tension.

ADJUSTING SPRING TENSION

Should less spring tension be desired, pull hose out from roller outlet to provide slack and latch reel.



CAUTION

To prevent premature power spring failure, spring tension should be adjusted so that it requires at least two full turns of the reel sheave before the spring is wound tight.

Unwind one loop of hose from reel. Pull excess hose out through roller outlet and unlatch reel to retract hose.

Check tension and repeat above procedure until desired tension is obtained.

ATTACHING CONNECTING HOSES



CAUTION

To prevent damage to connecting hose when installing hose to reel, sufficient clearance must be provided from outside edge of sheave.

Assemble connecting hose to optional (68601) reel inlet and secure. NOTE: A 90 degree swivel adapter or street elbow may be required in multiple reel bank installations.

Connect other end of connecting hose to material supply line source or connection.

REEL INSTALLATION AND ADJUSTMENT

See Figure (2). The guide arm may be positioned in 45 degree increments as shown. For ease of operation and increased hose life, the guide arm should be positioned to minimize hose strain as the delivery hose is pulled through the roller outlet.

Four studs must be used to securely attach the guide arm.

SAFETY INFORMATION

Read and understand all warnings, cautions and instructions before operating this equipment. Extreme caution should be used when operating this equipment as personal injury and/or property damage can result from equipment misuse. Adequate personal protection is recommended to prevent splashing of material on the skin or in the eyes. ALWAYS disconnect air coupler from pump when the pump is not being used.

PRESSURE RELIEF PROCEDURE

Always perform this procedure when the pump is shut off and before checking, servicing, installing, cleaning or repairing any part of this system.

Perform the following procedure:

- A. Disconnect the air supply to the pump.

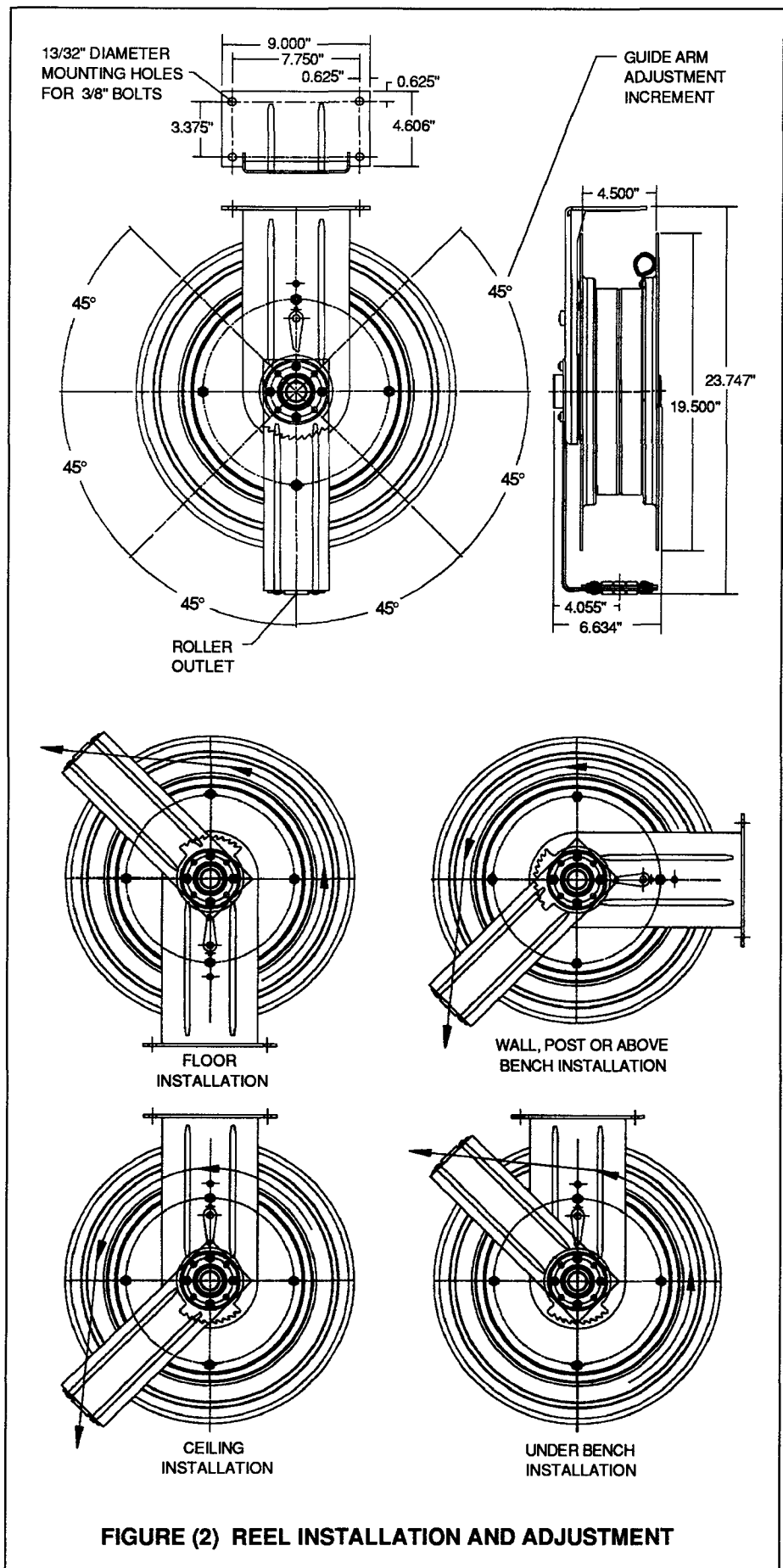

- B. Point the dispensing valve away from yourself and others.
- C. Open the dispensing valve into an appropriate container until the pressure is relieved.

If the above procedure does not relieve the pressure, the dispensing valve or hose may be restricted. To relieve the pressure, very slowly loosen the hose end coupling. Then loosen completely and clear the dispensing valve and/or hose.

INSPECTION

Prior to operation or maintenance a visual inspection shall be made. Check reel system for leaks, worn or missing parts.

Any reel that appears to be damaged in any way, is badly worn or operates abnormally shall be removed from use until repairs are made. Contact factory authorized service center for repairs.

If overpressurizing of the equipment is believed to have occurred, contact a factory authorized service center for inspection of the reel.

Annual inspection by a factory authorized service center is recommended.

DISASSEMBLY

To disassemble, perform ASSEMBLY procedures in reverse.

REPAIR

Repair is limited to replacement of listed service parts. Special procedures and tools are required. Contact Lincoln Customer Service, One Lincoln Way, St. Louis, MO 63120-1578, (314) 679-4300 for your nearest authorized service center.

When ordering replacement parts, list: part number, description, model number and series letter.

LIMITED WARRANTY

Lincoln, A Pentair Company, warrants that lubrication equipment, materials dispensing equipment and other related equipment manufactured by it will be free from defects in material and workmanship during the one (1) year following the date of purchase. If equipment proves to be defective during this warranty period, it will be repaired or replaced without charge, provided that factory examination indicates the equipment to be defective. To obtain repair or replacement, it must be shipped, transportation charges prepaid, with proof of date of purchase to a Lincoln authorized Warranty and Service Center, within the one (1) year following the date of purchase.

This warranty is extended to the original retail purchaser only. This warranty does not apply to equipment damaged from accident, overload, abuse, misuse, negligence, faulty installation or abrasive or corrosive materials, or to equipment repaired or altered by anyone not authorized by Lincoln to repair or alter the equipment. This warranty applies only to equipment installed and operated according to the recommendations of Lincoln or its authorized field personnel. No other express warranty applies to lubrication equipment, materials dispensing equipment, and other related equipment manufactured by Lincoln.

ANY IMPLIED WARRANTIES applicable to lubrication equipment, materials dispensing equipment, and other related equipment manufactured by Lincoln INCLUDING THE WARRANTIES OF MERCHANTABILITY AND FITNESS FOR A PARTICULAR PURPOSE, WILL LAST ONLY FOR ONE (1) YEAR FROM THE DATE OF PURCHASE. SOME STATES DO NOT ALLOW LIMITATIONS ON HOW LONG AN IMPLIED WARRANTY LASTS, SO THE ABOVE LIMITATION MAY NOT APPLY TO YOU.

In no event shall Lincoln be liable for incidental or consequential damages. The liability of Lincoln on any claim for loss or damage arising out of the sale, resale, or use of lubrication equipment, materials dispensing equipment, and other related equipment shall in no event exceed the purchase price. SOME STATES DO NOT ALLOW THE EXCLUSION OR LIMITATION OF INCIDENTAL OR CONSEQUENTIAL DAMAGES, SO THE ABOVE LIMITATION OR EXCLUSION MAY NOT APPLY TO YOU.

THIS WARRANTY GIVES YOU SPECIFIC LEGAL RIGHTS AND YOU MAY ALSO HAVE OTHER RIGHTS WHICH VARY FROM STATE TO STATE.

SERVICE

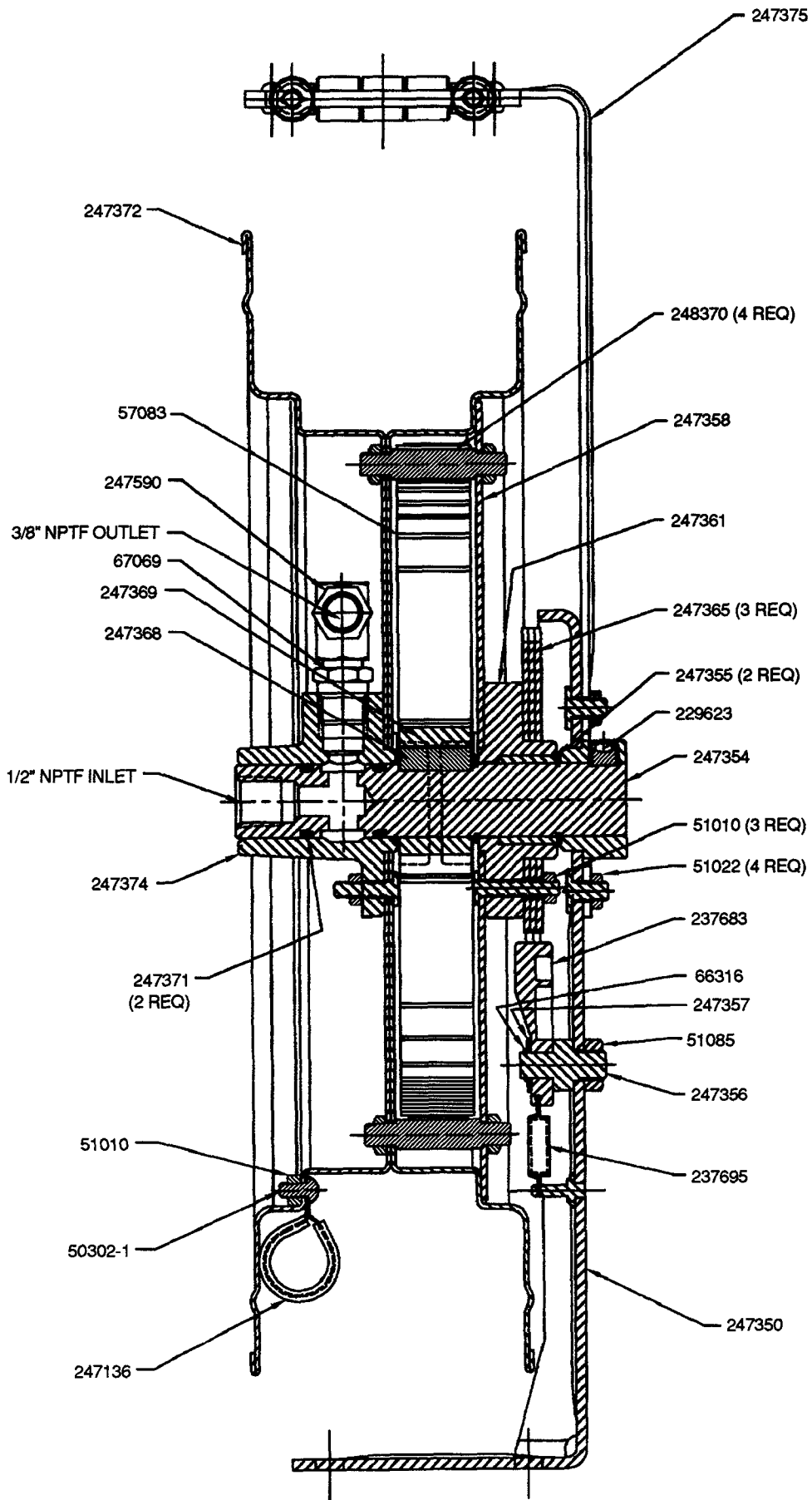

SERVICE PARTS (CONT)

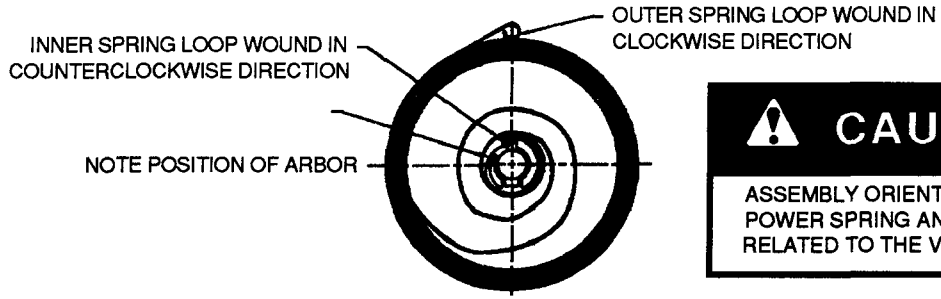

CAUTION

ASSEMBLY ORIENTATION OF POWER SPRING AND ARBOR IS RELATED TO THE VIEW BELOW.

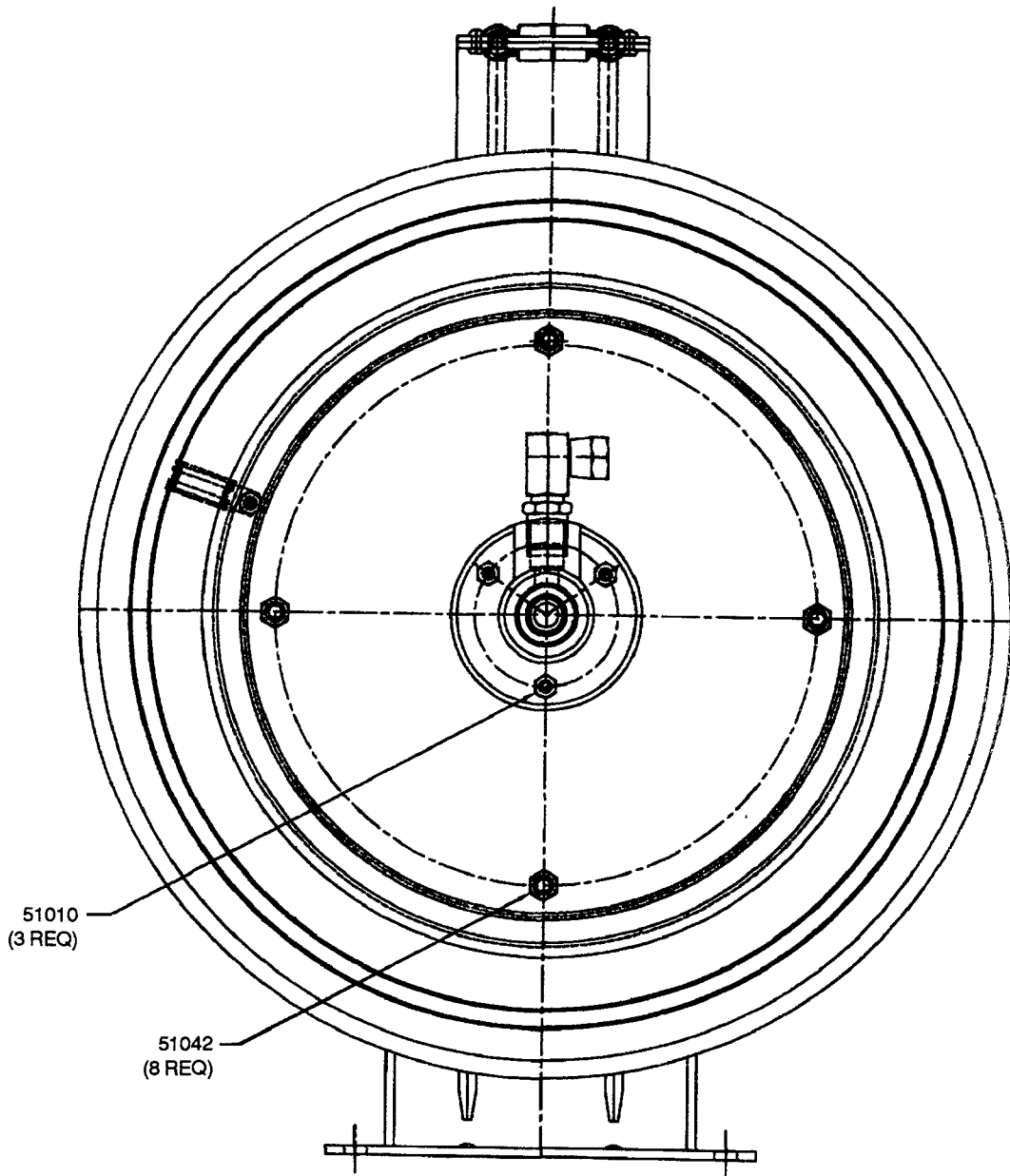

SERVICE PARTS (CONT)

PART	QTY	DESCRIPTION
50302-1	1	Screw
51010	7	Hex nut
51022	4	Hex nut
51042	8	Hex jamnut
51085	1	Hex nut
57083	1	Power spring
66316	1	Retaining ring
67069	1	Reducing bushing
229623	1	Set screw
237683	1	Pawl
237695	1	Pawl spring
247136	1	Hose clamp
247350	1	Support assembly
247354	1	Axle
247355	2	Retaining ring
247356	1	Pawl pin
247357	1	Washer
247358	1	Spring cover assembly
247361	1	Latch hub assembly
247365	3	Latch plate
247368	1	Arbor key
247369	1	Arbor
247371	2	O-ring
247372	1	Sheave assembly
247374	1	Swivel hub
247375	1	Roller arm assembly
247590	1	Adapter union
248370	4	Stud