

OWNER/OPERATOR MANUAL

SPECIFICATIONS

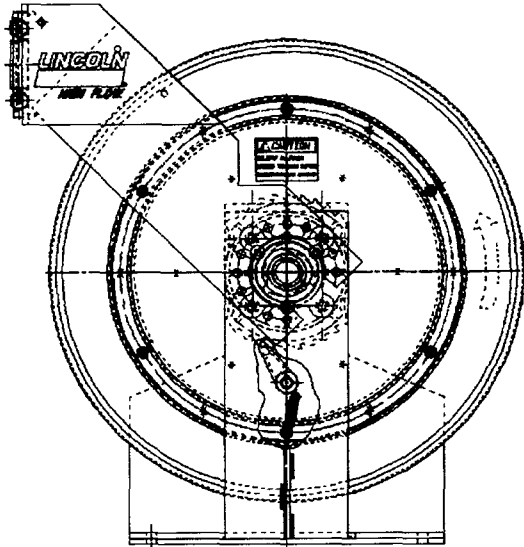

Maximum working pressure	2000 p.s.i.
Material Inlet	3/4" NPT (Female)
Material outlet	3/4" NPT (Female)
Sheave width	10"
Sheave diameter	19-1/4"
Drum diameter	12-3/4"
Overall width	15-1/2"
Overall height	22-1/2"
Overall depth	21"

Maximum hose capacities (Including hang down):

1/2" I.D. Air hose (SAE 100 R6)	75 ft.
1/2" I.D. Oil hose (SAE 100 R3)	75 ft.
5/8" I.D. Oil hose (SAE 100 R1)	75 ft.
3/4" I.D. Air hose (SAE 100 R3)	75 ft.
3/4" I.D. Oil hose (SAE 100R1)	75 ft.

NOTE: Maximum hose capacities are based on SAE specified hoses. Exceeding these capacities voids warranty. Refer to DELIVERY HOSE INSTALLATION for proper hose to reel assembly.

IMPORTANT

THIS HOSE REEL ROLLER OUTLET REQUIRES 3-5/8" BALL STOPS, MODELS 85515, 85516 AND 85517. DO NOT USE MODELS 83515, 83516 AND 83517 (3" O.D.) BALL STOPS WITH THIS OUTLET.

DESCRIPTION

Model 84673 unit is a heavy duty lubreel designed for bus and truck lubrication or wherever extra heavy duty construction and longer length delivery hose is required. The reel can be installed as a single unit or in multiple configurations.

Reel features include a reel latch that automatically locks at desired positions as the hose is extended and releases with a short pull on the hose.

OWNER/OPERATOR RESPONSIBILITY

It is the owner/operator responsibility to properly use and maintain this equipment.

The instructions and warnings contained in this manual shall be read and understood by the owner/operator prior to operating this equipment.

If an owner/operator does not under-

stand English, the contents of this manual shall be explained in the owner/operator native language to assure the owner/operator comprehends.

It is the owner/operator responsibility to maintain the legibility of all warning and instruction labels.

The owner/operator shall retain this manual for future reference to important warnings, operating and maintenance instructions.

WARNING

FAILURE TO HEED THE FOLLOWING WARNINGS INCLUDING MISUSE, OVER PRESSURIZING, MODIFYING PARTS, USING INCOMPATIBLE CHEMICALS AND FLUIDS, OR USING WORN OR DAMAGED PARTS, MAY RESULT IN EQUIPMENT DAMAGE AND/OR SERIOUS PERSONAL INJURY, FIRE, EXPLOSION, OR PROPERTY DAMAGE.

- Do not exceed the stated maximum working pressure of the reel or of the lowest rated component in your system.
- Do not alter or modify any part of this equipment.
- Do not operate this equipment with combustible gas.
- Do not attempt to repair or disassemble the equipment while the system is pressurized.
- Make sure all fluid connections are securely tightened before using this equipment.
- Always read and follow the fluid manufacturer's recommendations regarding fluid compatibility, and the use of protective clothing and equipment.
- Check all equipment regularly and repair or replace worn or damaged parts immediately.
- Never point the dispensing valve at any part of the body or at another person.
- Never try to stop or deflect material from dispensing valve or leading connection or component with your hand or body.
- Always check equipment for proper operation before each use, making sure safety devices are in place and operating properly.
- Always follow the pressure relief procedure after shutting off the pump, when checking or servicing any part of the system, and when installing, cleaning or changing any part of the system.

ASSEMBLY

Assemble reel as follows. Refer to SERVICE PARTS for part numbers and location.

- | | | |
|----------------------------------------------------------------------------------------------------------------------------------------------------------------------------------------------------------------------------------------------------------------------------------------------------------------------------------------------------------------------------------------------------------------------------------------------------------------------------------------------------------------------------------------------------------------------------|---------------------------------------------------------------------------------------------------------------------------------------------------------------------------------------------------------------------------------------------------------------------------------------------------------------------------------------------------------------------------------------------------------------------------------------------------------------------------------------------------------------------------------------------------------------------------------------------------------------------------------------------------------------|--------------------------------------------------------------------------------------------------------------------------------------------------------------------------------------------------------------------------------------------------------------------------------------------------------------------------------------------------------------------------------------------------------------------------------------------------------------------------------------------------------------------------------------------------------------------------------------------------------------------------------------------------------------------------------|
| <p>A. Assemble arbor and ratchet casting (237769) to support assembly (237656) with hex head screws (50014) and secure with hex nuts (51022).</p> <p>B. Lubricate V-ring seal (237671) and assemble onto arbor and ratchet casting (237769) with lip facing away from arbor ratchet.</p> <p>C. Assemble power spring assembly (237768) onto arbor and ratchet casting (237769) until spring canister bottoms on arbors shoulder.</p> <p>D. Lubricate V-ring seal (237673) and assemble onto arbor and ratchet casting (237769) with lip facing toward spring canister.</p> | <p>E. Assemble axle assembly (242000) to sheave assembly (237771) and secure with standoffs (237780).</p> <p>F. Assemble axle and sheave assembly to reel by sliding the axle assembly (242000) through the bearings in the arbor and ratchet casting (237769) and securing with washer (48217) and Tru-arc (68424).
Note: Shim as required using shims (48385) between washer (48217) and arbor and ratchet casting (237769) to eliminate axle end play.</p> <p>G. Assemble outboard axle assembly (237781) to standoffs (237780) and secure with nuts (51010).</p> <p>H. Rotate sheave assembly (237771) and align mounting holes with mating holes</p> | <p>in power spring canister (237768) and secure using carriage bolts (237738), carriage bolt (237739) and nuts (51010).
Note: The carriage bolt (237739) (.875 long) must be assembled in hole adjacent to pawl pin on power spring assembly.</p> <p>I. Assemble roller outlet arm assembly (237778) on bolts (50014) and secure using nuts (51022).</p> <p>J. Assemble roller outlet assembly (237692) to roller outlet arm assembly (237778) by snapping into stamped out contour in roller outlet arm.
Note: Make certain that snap-locks are firmly seated after assembling.</p> <p>K. Assemble swivel assembly (84679) in axle assembly (242000) and tighten.</p> |
|----------------------------------------------------------------------------------------------------------------------------------------------------------------------------------------------------------------------------------------------------------------------------------------------------------------------------------------------------------------------------------------------------------------------------------------------------------------------------------------------------------------------------------------------------------------------------|---------------------------------------------------------------------------------------------------------------------------------------------------------------------------------------------------------------------------------------------------------------------------------------------------------------------------------------------------------------------------------------------------------------------------------------------------------------------------------------------------------------------------------------------------------------------------------------------------------------------------------------------------------------|--------------------------------------------------------------------------------------------------------------------------------------------------------------------------------------------------------------------------------------------------------------------------------------------------------------------------------------------------------------------------------------------------------------------------------------------------------------------------------------------------------------------------------------------------------------------------------------------------------------------------------------------------------------------------------|

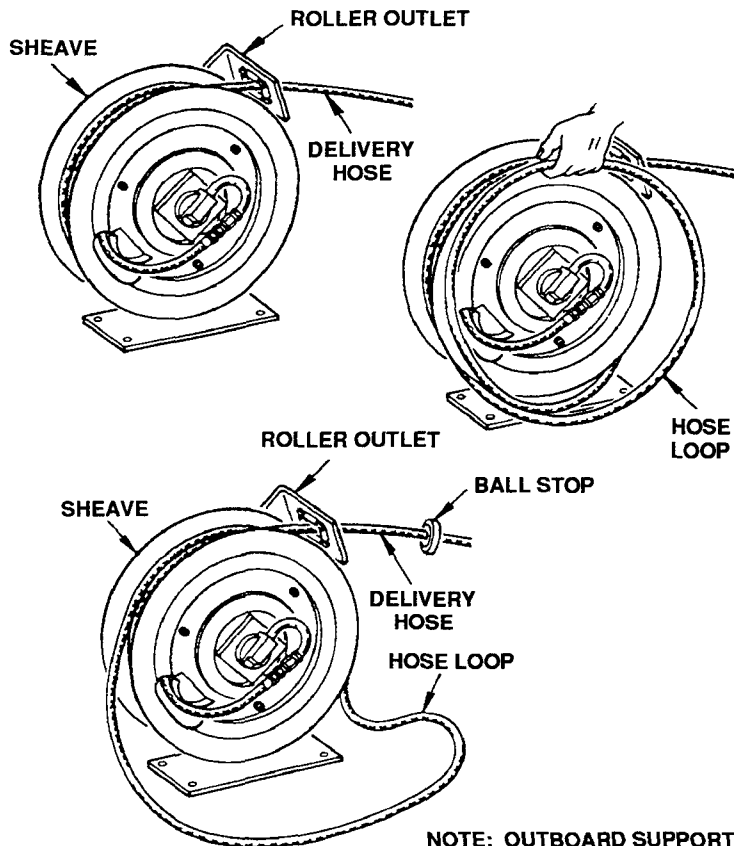

NOTE: OUTBOARD SUPPORT MUST BE REMOVED WHILE ADJUSTING SPRING TENSION.

FIGURE (1) DELIVERY HOSE

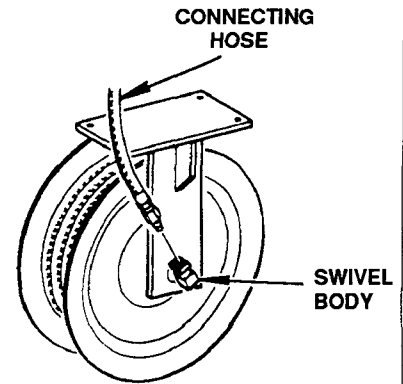

FIGURE (2) CONNECTING HOSE

INSTALLATION

DELIVERY HOSE INSTALLATION (MAXIMUM SPRING TENSION)

For smoother operation during retraction and to increase hose life, "detalc" hose by wiping entire hose length with a light lubricating oil before installing on reel.

Assemble outlet adapter to hose and tighten securely. Use teflon tape on threads to prevent leaks.

See Figure (1). Insert hose end with outlet adapter through roller outlet and secure to axle head with U-keeper. Make sure seal is installed correctly in axle before assembling.

CAUTION

To prevent damaging hose connections and/or components when pulling hose from reel, pull on the hose itself and not on the control valve or swivel. Do not pull or jerk on the hose when fully withdrawn from the reel.

- L. Assemble swivel outlet adapter (242015) into the axle assembly (242000) and secure.
- M. Assemble hose clamp (237760) to sheave assembly (237771) with carriage bolt (237738) and secure with nut (51010).
- N. Assemble pawl (237683) to pawl pin on spring canister (237768) and secure with washer (48327) and Tru-arc (66316).
- O. Assemble pawl spring (237695) to pawl (237683) and carriage bolt (237739) and secure with locknut (51304).
- P. Assemble outboard bearing assembly (237784) to outboard support (237787) using screws (50016). **HAND TIGHTEN ONLY AT THIS POINT.**
- Q. Assemble outside bearing assembly and support to reel assembly by sliding outboard axle through bearing. Align two .406 mounting holes in both base and support and insert one roll pin in each hole.
- R. Adjust/align outside bearing assembly for free drum rotation and tighten screws (50016).

From open side of reel (with outside support removed), loop entire length of hose onto reel in a clockwise direction. Pull hose out through roller outlet to wind power spring. When hose is completely extended, latch reel to prevent it from unwinding.

Continue to add loops of hose and pull out hose until power spring winds tight.

IMPORTANT INSTRUCTIONS

Perform the following instructions as stated to correctly set the power spring for maximum tension.

Allow reel to retract two full revolutions and latch reel. Carefully unloop remaining hose from reel.

CAUTION

To avoid damaging reel components, always make sure hose clamp is properly installed.

Position hose clamp so that approximately 1/2 loop of hose remains on reel and latching does not occur when hose is fully extended.

Slide ball stop over free end of hose and position slightly below roller outlet. Tighten screws to secure ball stop to hose.

Power spring is now set to maximum tension.

ADJUSTING SPRING TENSION

CAUTION

To prevent premature power spring failure, spring tension should be adjusted so that it requires at least two full turns of the reel sheave before the spring is wound tight.

Should less spring tension be desired, pull hose out from roller outlet to provide slack and latch reel.

Unwind one loop of hose from reel. Pull excess hose out through roller outlet and unlatch reel to retract hose.

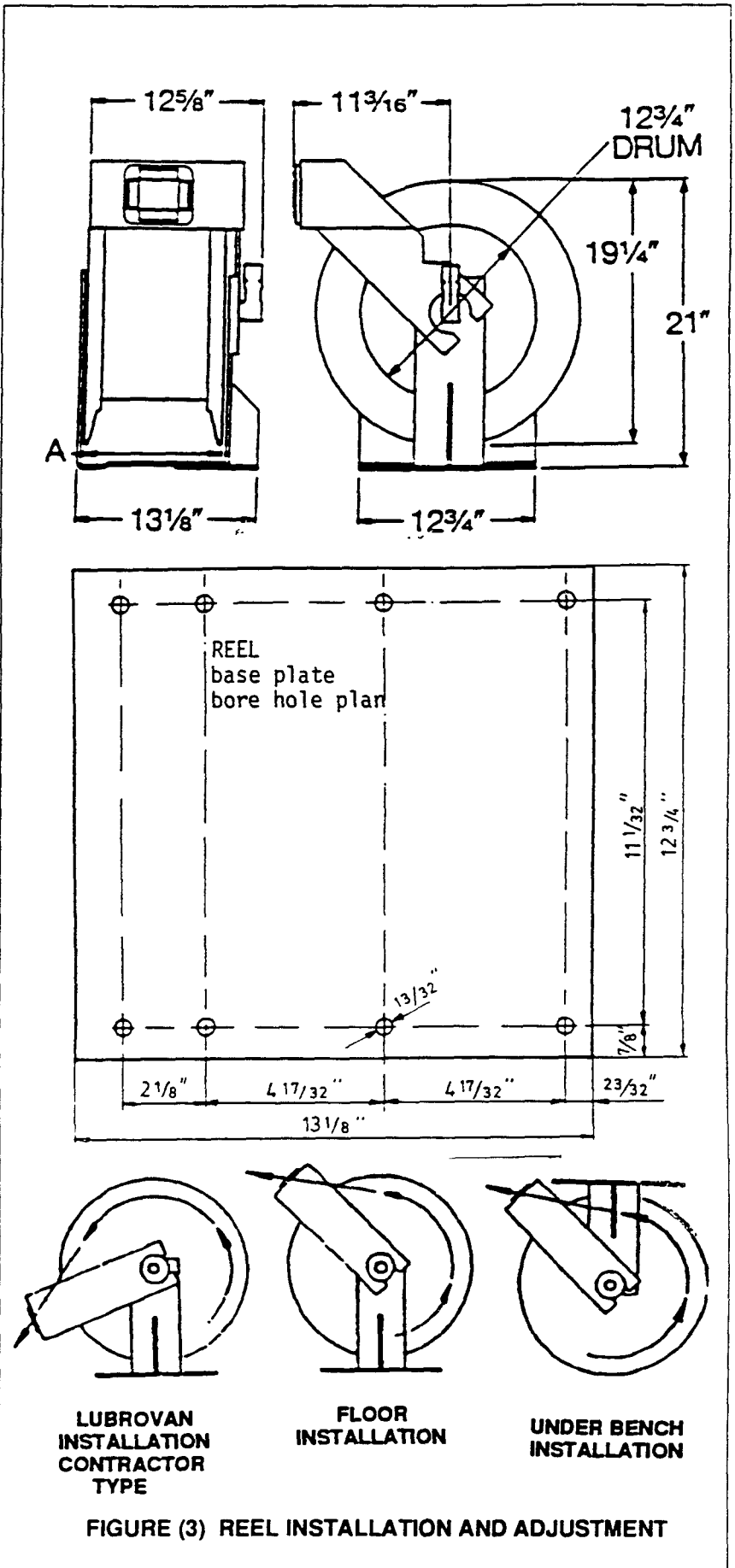
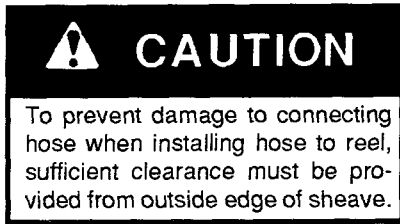

FIGURE (3) REEL INSTALLATION AND ADJUSTMENT

Check tension and repeat above procedure until desired tension is obtained.

Reattach/assemble outboard support to reel. (See Page 3, Steps P thru R).

ATTACHING CONNECTING HOSES



See Figure (2). Reconnect inlet adapter to swivel body and replace U-keeper.

Connect other end of connecting hose to material supply line source or connection.

REEL INSTALLATION AND ADJUSTMENT

See Figure (3). The guide arm may be positioned in 22-1/2 degree increments as shown. For ease of operation and increased hose life, the guide arm should be positioned to minimize hose strain as the delivery hose is pulled through the roller outlet.

Three studs must be used to securely attach the guide arm. It may be necessary to change the position of the hex head screw and one stud in order to obtain the desired guide arm position.

The hose clamp must be relocated if the guide arm is repositioned

SAFETY INFORMATION

Read and understand all warnings, cautions and instructions before operating this equipment. Extreme caution should be used when operating this equipment as personal injury and/or property damage can result from equipment misuse. Adequate personal protection is recommended to prevent splashing of material on the skin or in the eyes. ALWAYS disconnect air coupler from pump when the pump is not being used.

PRESSURE RELIEF PROCEDURE

Always perform this procedure when the pump is shut off and before checking, servicing, installing, cleaning or repairing any part of this system.

Perform the following procedure:

- A. Disconnect the air supply to the pump.
- B. Point the dispensing valve away from yourself and others.
- C. Open the dispensing valve into an appropriate container until the pressure is relieved.

If the above procedure does not relieve the pressure, the dispensing valve or hose may be restricted. To relieve the pressure, very slowly loosen the hose end coupling. Then loosen completely and clear the dispensing valve and/or hose.

INSPECTION

Prior to operation or maintenance a visual inspection shall be made. Check reel system for leaks, worn or missing parts.

Any reel that appears to be damaged in any way, is badly worn or operates abnormally shall be removed from use until repairs are made. Contact factory authorized service center for repairs.

If overpressurizing of the equipment is believed to have occurred, contact a factory authorized service center for inspection of the reel.

Annual inspection by a factory authorized service center is recommended.

DISASSEMBLY

To disassemble, perform ASSEMBLY procedures in reverse.

REPAIR

Repair is limited to replacement of listed service parts. Special procedures and tools are required. Contact Lincoln Customer Service, One Lincoln Way, St. Louis, MO 63120-1578, (314) 679-4300 for your nearest authorized service center.

When ordering replacement parts, list: part number, description, model number and series number.

LIMITED WARRANTY

Lincoln, A Pentair Company, warrants that lubrication equipment, materials dispensing equipment and other related equipment manufactured by it will be free from defects in material and workmanship during the one (1) year following the date of purchase. If equipment proves to be defective during this warranty period, it will be repaired or replaced without charge, provided that factory examination indicates the equipment to be defective. To obtain repair or replacement, it must be shipped, transportation charges prepaid, with proof of date of purchase to a Lincoln authorized Warranty and Service Center, within the one (1) year following the date of purchase.

This warranty is extended to the original retail purchaser only. This warranty does not apply to equipment damaged from accident, overload, abuse, misuse, negligence, faulty installation or abrasive or corrosive materials, or to equipment repaired or altered by anyone not authorized by Lincoln to repair or alter the equipment. This warranty applies only to equipment installed and operated according to the recommendations of Lincoln or its authorized field personnel. No other express warranty applies to lubrication equipment, materials dispensing equipment, and other related equipment manufactured by Lincoln.

ANY IMPLIED WARRANTIES applicable to lubrication equipment, materials dispensing equipment, and other related equipment manufactured by Lincoln INCLUDING THE WARRANTIES OF MERCHANTABILITY AND FITNESS FOR A PARTICULAR PURPOSE, WILL LAST ONLY FOR ONE (1) YEAR FROM THE DATE OF PURCHASE. SOME STATES DO NOT ALLOW LIMITATIONS ON HOW LONG AN IMPLIED WARRANTY LASTS, SO THE ABOVE LIMITATION MAY NOT APPLY TO YOU.

In no event shall Lincoln be liable for incidental or consequential damages. The liability of Lincoln on any claim for loss or damage arising out of the sale, resale, or use of lubrication equipment, materials dispensing equipment, and other related equipment shall in no event exceed the purchase price. SOME STATES DO NOT ALLOW THE EXCLUSION OR LIMITATION OF INCIDENTAL OR CONSEQUENTIAL DAMAGES, SO THE ABOVE LIMITATION OR EXCLUSION MAY NOT APPLY TO YOU.

THIS WARRANTY GIVES YOU SPECIFIC LEGAL RIGHTS AND YOU MAY ALSO HAVE OTHER RIGHTS WHICH VARY FROM STATE TO STATE.

SERVICE PARTS

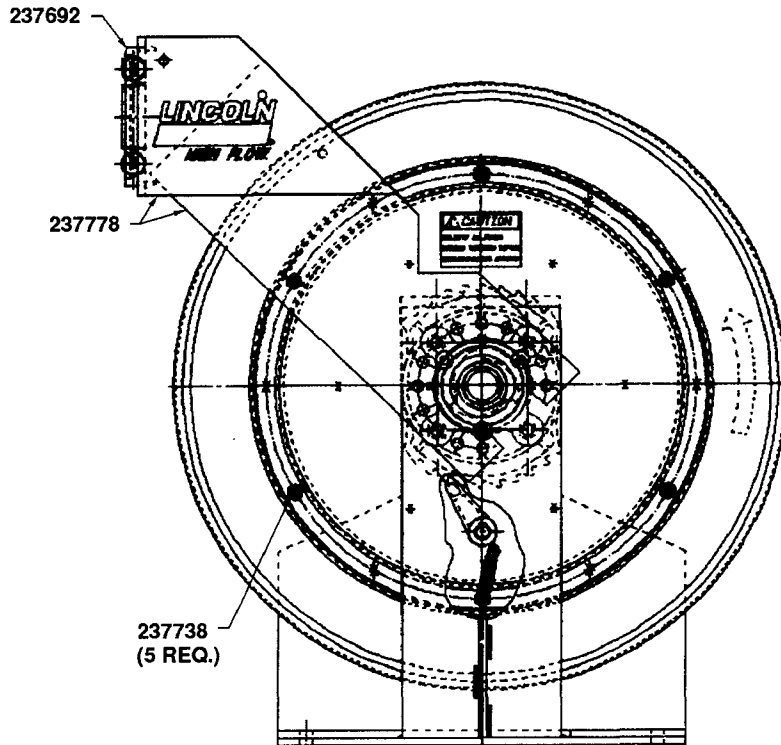
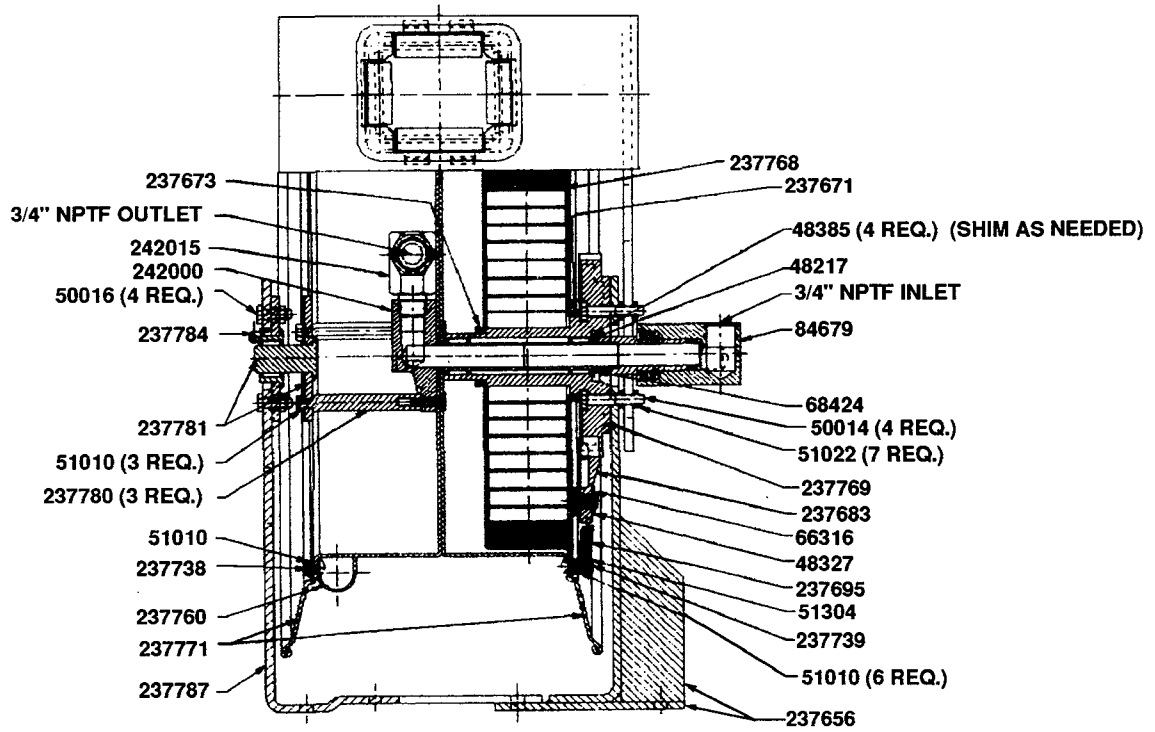

SERVICE PARTS (CONT)

PART	QTY	DESCRIPTION	PART	QTY	DESCRIPTION
16684	1	Swivel body	237656	1	Support assembly
16685	1	Swivel stem	237671	1	V-ring seal
31116	1	Gasket	237673	1	V-ring seal
48217	1	Washer	237683	1	Latch pawl
48327	1	Washer	237692	1	Roller outlet assembly
48385	4	Shim washer	237695	1	Extension spring
48652	1	Washer	237738	6	Carriage bolt
48653	1	Washer	237739	1	Carriage bolt
50014	4	Hex head screw	237760	1	Hose clamp
50016	4	Hex head screw	237768	1	Power spring assembly
51010	10	Hex nut	237769	1	Arbor and ratchet casting
51022	7	Hex nut	237771	1	Sheave assembly
51304	1	Locknut	237778	1	Roller outlet arm assembly
66316	1	Tru-arc	237780	3	Stand off
68424	1	Tru-arc	237781	1	Outboard axle assembly
70515	2	Retaining ring	237784	1	Outboard bearing assembly
70516	1	Retaining ring	237787	1	Outboard support
70517	2	Thrust washer	242000	1	Axle assembly
70518	1	U-cup packing	242015	1	Swivel adapter
70519	1	Thrust bearing	242505	1	Nipple
84679	1	Swivel assembly	242506	1	Elbow

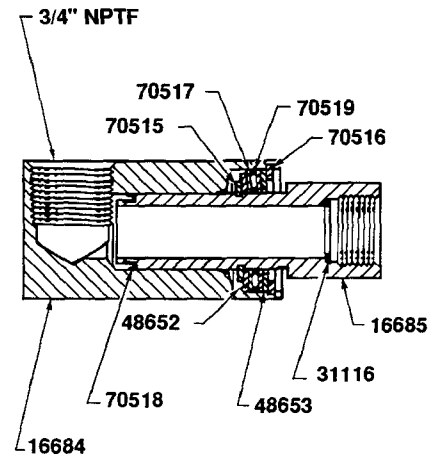
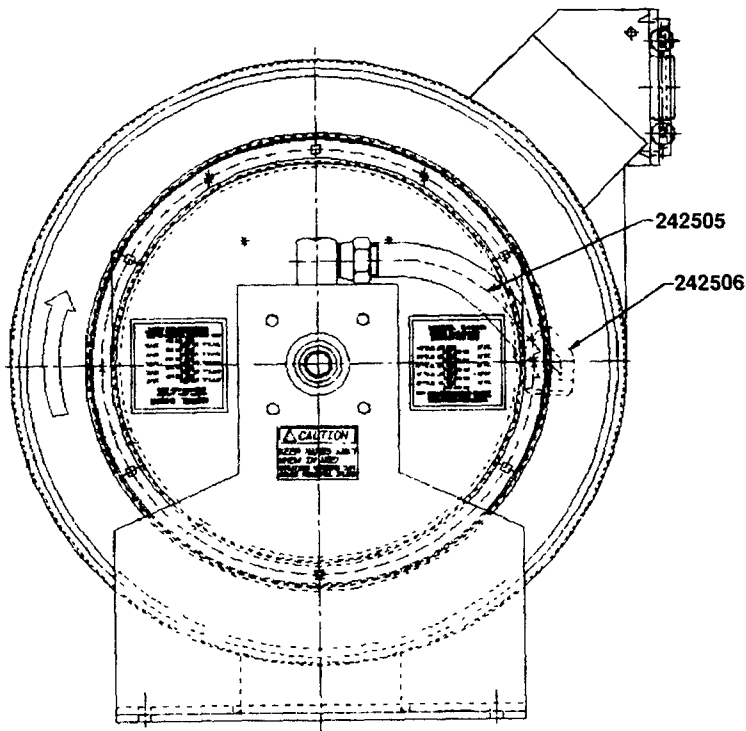

84679 SWIVEL ASSEMBLY

IMPORTANT

PART NUMBERS 242505 NIPPLE AND 242506 ELBOW ARE REQUIRED FOR PROPER DELIVERY HOSE INSTALLATION ON LARGE I.D. HOSES (5/8" I.D. AND LARGER).