

SERVICE PARTS LIST

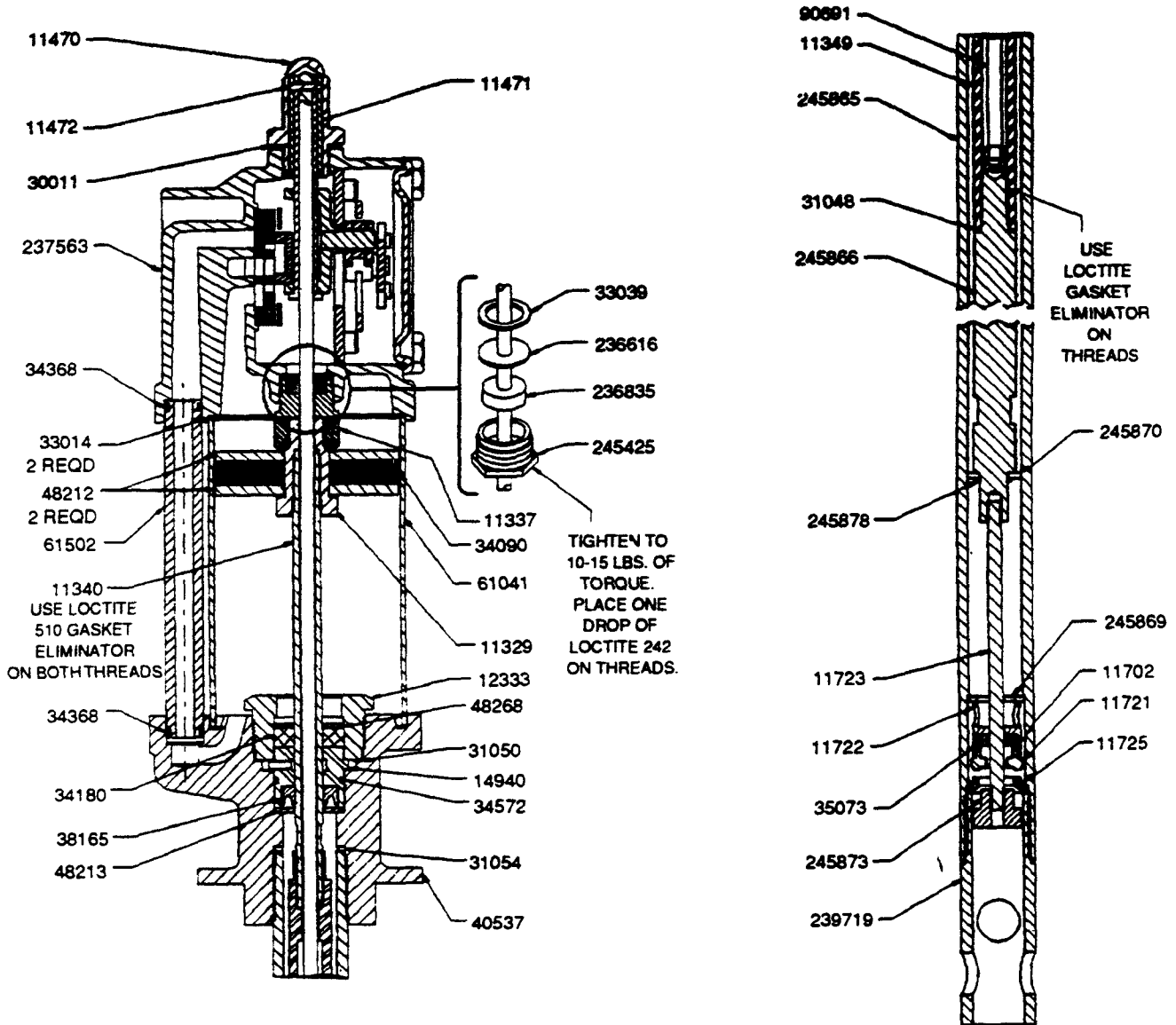

DISASSEMBLY

⚠ WARNING

To prevent personal injury, perform PRESSURE RELIEF PROCEDURE before and after operating the pump and before performing any disassembly or assembly.

NOTE

If complete disassembly is required, order the repair kit and replace ALL gaskets, O-rings and packings.

A. Remove valve cap (11470), trip rod pin (11472) and trip collar (11471). Unscrew trip sleeve (11947) from trip rod (90691).

B. Unscrew four tie rod nuts (51009) from tie rods (10294) and lift air valve casting (237563) off of air cylinder (61041).

C. Remove packing nut (11904) and packing cap (11905) from air valve casting.

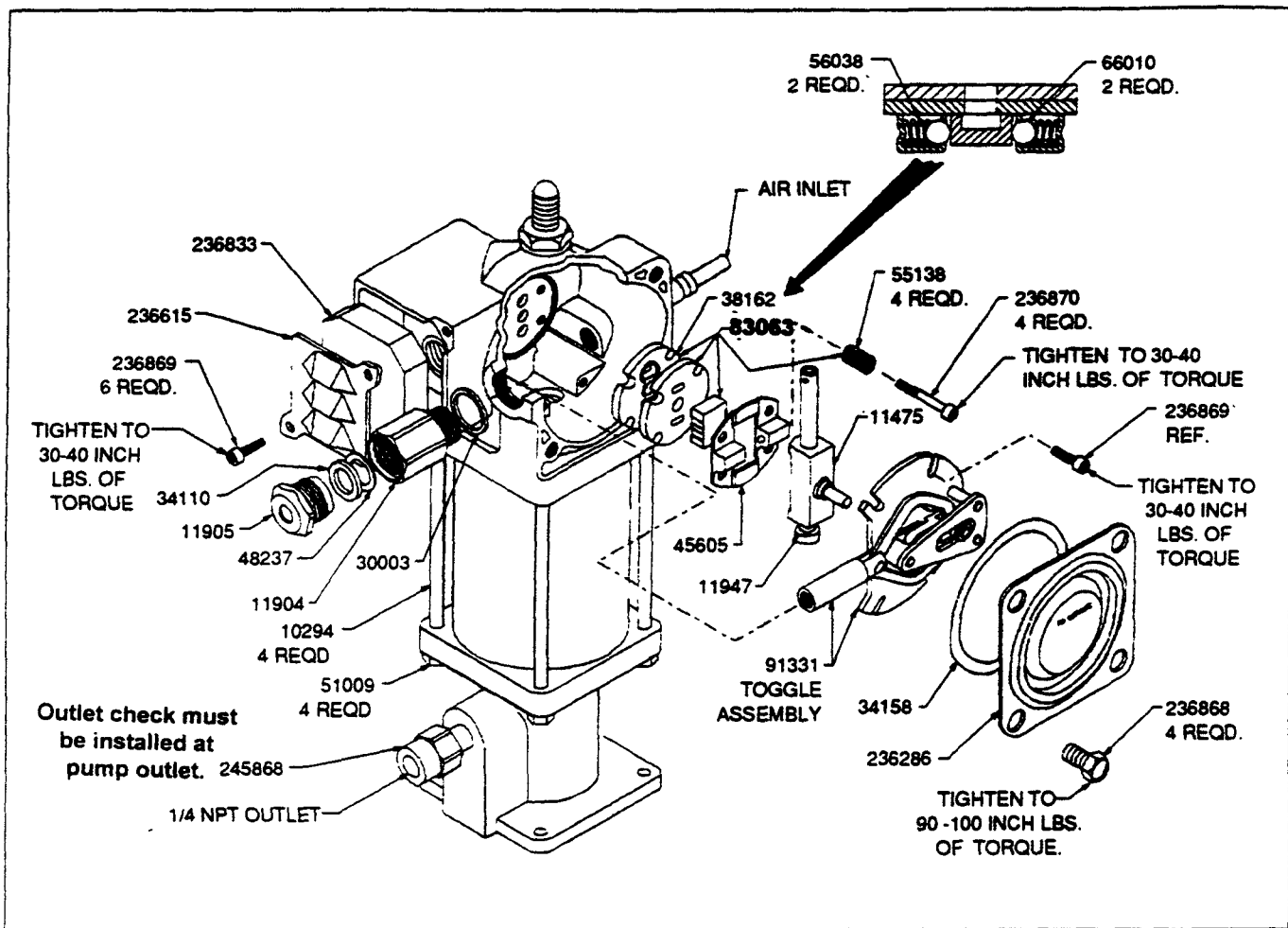

- D. Remove four valve cover screws (236868) and cover (236286).
- E. Remove four socket head screws (236869), toggle assembly (91331), trip shoe (11475) and trip sleeve (11947).
- F. Remove four valve seat bolts (236870), springs (55138), valve guide plate (45605) and valve slide and seat (86063) and gasket (38162).
- G. Unscrew trip rod packing nut (245425) from air valve casting and remove all packing parts.
- H. Remove priming tube (239719) from pump tube.
- I. Extend priming plunger (245873) through the bottom of pump tube. Place a wrench on the priming plunger (245873) and on piston bolt (11329) to remove all lower check parts.
- J. Remove pump tube from outlet

casting (40537). Remove pump rod from connector rod (11349).

- K. Remove gland packing nut (12333) from outlet body and remove all gland parts and piston rod (11340).

ASSEMBLY

To reassemble, perform DISASSEMBLY procedures in reverse. Tighten fasteners per stated torque specifications.

IMPORTANT: To prevent damage to air piston packing and pump gland packing, and help to increase packing life, lubricate air cylinder and air piston rod before assembly. Thread piston rod through gland packing when assembling pump.

Before tightening four valve seat screws (236870), align valve slide and seat plate (83063), slide valve gasket (38162) and air valve casting (237563) by placing a rod through the center hole.

Start all fasteners by hand to avoid stripping threads when reassembling.

Check valve (245868) must be installed into pump outlet for proper operation of the pump. Be sure check valve has a ball and spring inside

REPAIR

Repair is limited to replacement of listed service parts. Special procedures and tools are required. Contact Lincoln Customer Service, One Lincoln Way, St. Louis, MO 63120-1578, (314) 679-4300 for your nearest authorized service center.

When ordering replacement parts, list: part number, description, model number and series letter.

PRESSURE RELIEF PROCEDURE

Always perform this procedure when the pump is shut off and before checking, servicing, installing, cleaning or repairing any part of this system.

PARTS	QTY	DESCRIPTION	PARTS	QTY	DESCRIPTION
10294	4	Tie rod	45605	1	Valve guide plate
11329	1	Air piston bolt	48212	2	Air piston washer
11337	1	Air piston nut	48213	1	Gland packing washer
11340	1	Air motor piston rod	48237	1	Plunger packing washer
11349	1	Connector rod	48268	1	Gland packing washer
11470	1	Valve cap	51009	4	Tie rod nut
11471	1	Trip collar	55138	4	Spring
11472	1	Trip pin	56038	2	Spring
11475▲	1	Trip shoe	61041▲	1	Air cylinder
11702	1	Check washer	61502	1	Air passage tube
11721	1	Priming check	66010	2	Ball
11722	1	Check stop	83063	1	Valve slide & seat
11723	1	Plunger rod	90691▲	1	Trip rod
11725	1	Priming check seat	91331▲	1	Toggle assembly
11904	1	Packing nut	236286	1	Cover
11905	1	Packing cap	236615	1	Muffler cover
11947	1	Trip sleeve	236616▲	1	Packing washer
12333	1	Gland packing nut	236833	1	Muffler
14940	1	Gland packing spacer	236835▲	1	Trip rod packing
30003	1	Packing nut gasket	236868	4	Valve cover screw
30011	1	Valve cap gasket	236869	6	Socket head screw
31048	1	Connector gasket	236870	4	Valve seat bolt
31050	1	Gland gasket	237563	1	Air head casting
31054	1	Pump tube gasket	239719	1	Priming tube
33014	2	Air cylinder gasket	245425	1	Trip rod packing nut
33039	1	Gasket	245865	1	Pump tube
34090▲	1	Air piston packing	245866	1	Pump rod
34110	1	Plunger packing	245868▲	1	Check valve assembly
34158	1	Cover gasket	245869	1	Valve stop
34180▲	1	Gland packing	245870	1	Plunger rod guide
34368	2	O-ring	245873	1	Priming plunger
34572	1	O-ring	245878	1	Retaining ring
35073▲	1	Priming check packing			
38162	1	Slide valve gasket			
38165▲	1	U-cup packing			
40537	1	Outlet body			

▲ Recommended Service Part.

Perform the following procedure:

- A. Disconnect the air supply to the pump.
- B. Point the dispensing valve away from yourself and others
- C. Open the dispensing valve into an appropriate container until the pressure is relieved.

If the above procedure does not relieve the pressure, the dispensing valve or hose may be restricted. To relieve the pressure, very slowly loosen the hose end coupling. Then loosen completely and clear the dispensing valve and/or hose.

TROUBLESHOOTING

If the following procedures do not correct the problem, contact a factory authorized service center. When submitting equipment to be repaired, be sure to state the nature of the problem and indicate if a repair cost estimate is required.

PROBLEMS

AIRMOTOR DOES NOT OPERATE.

- Check air supply to pump.
- Check for broken trip rod.
- Broken toggle or foreign object lodged in priming tube. Check for rust, worn or scored parts.

AIR SEEPAGE FROM AIR EXHAUST WHILE PUMP IS NOT OPERATING

- Check valve slide (83063), seat and gasket. Check trip rod packing (236835) and gasket (33039) for cut or damaged packing.

LOSS OF PRESSURE, VOLUME OR CONTINUOUS OPERATION OF PUMP WHEN NOT IN NORMAL USE.

- Remove and clean lower inlet check. Check for foreign materials.

- Remove and clean discharge check valve assembly (245868). Be sure check valve has a ball and spring inside for proper pump operation
- Check that pump tube gasket is not leaking.

LUBRICANT LEAKING FROM WEEP HOLE IN OUTLET CASTING

- Replace O-ring (34572) and U-cup (38165). Make sure gland nut (12333) is tight.

EXCESSIVE AMOUNT OF AIR IN LUBRICANT OR EXCESSIVE AMOUNT OF LUBRICANT COMING FROM AIR EXHAUST.

NOTE

Some lubricant exhausts with air normally

- Replace gland packing (34180), gland gasket (31050), O-ring (34572) and u-cup packing (38165).

LIMITED WARRANTY

Lincoln, A Pentair Company, warrants that lubrication equipment, materials dispensing equipment and other related equipment manufactured by it will be free from defects in material and workmanship during the one (1) year following the date of purchase. If equipment proves to be defective during this warranty period, it will be repaired or replaced without charge, provided that factory examination indicates the equipment to be defective. To obtain repair or replacement, it must be shipped, transportation charges prepaid, with proof of date of purchase to a Lincoln authorized Warranty and Service Center, within the one (1) year following the date of purchase.

This warranty is extended to the original retail purchaser only. This warranty does not apply to equipment damaged from accident, overload, abuse, misuse, negligence, faulty installation or abrasive or corrosive materials, or to equipment repaired or altered by anyone not authorized by Lincoln to repair or alter the equipment. This warranty applies only to equipment installed and operated according to the recommendations of Lincoln or its authorized field personnel. No other express warranty applies to lubrication equipment, materials dispensing equipment, and other related equipment manufactured by Lincoln.

ANY IMPLIED WARRANTIES applicable to lubrication equipment, materials dispensing equipment, and other related equipment manufactured by Lincoln INCLUDING THE WARRANTIES OF MERCHANTABILITY AND FITNESS FOR A PARTICULAR PURPOSE, WILL LAST ONLY FOR ONE (1) YEAR FROM THE DATE OF PURCHASE. SOME STATES DO NOT ALLOW LIMITATIONS ON HOW LONG AN IMPLIED WARRANTY LASTS, SO THE ABOVE LIMITATION MAY NOT APPLY TO YOU.

In no event shall Lincoln be liable for incidental or consequential damages. The liability of Lincoln on any claim for loss or damage arising out of the sale, resale, or use of lubrication equipment, materials dispensing equipment, and other related equipment shall in no event exceed the purchase price. SOME STATES DO NOT ALLOW THE EXCLUSION OR LIMITATION OF INCIDENTAL OR CONSEQUENTIAL DAMAGES, SO THE ABOVE LIMITATION OR EXCLUSION MAY NOT APPLY TO YOU.

THIS WARRANTY GIVES YOU SPECIFIC LEGAL RIGHTS AND YOU MAY ALSO HAVE OTHER RIGHTS WHICH VARY FROM STATE TO STATE.