

---

**FlowMaster™ Single Action Rotary Driven Hydraulic Pump  
For 5 Gallon Pail/Container  
Model: 85486 Series "A"**

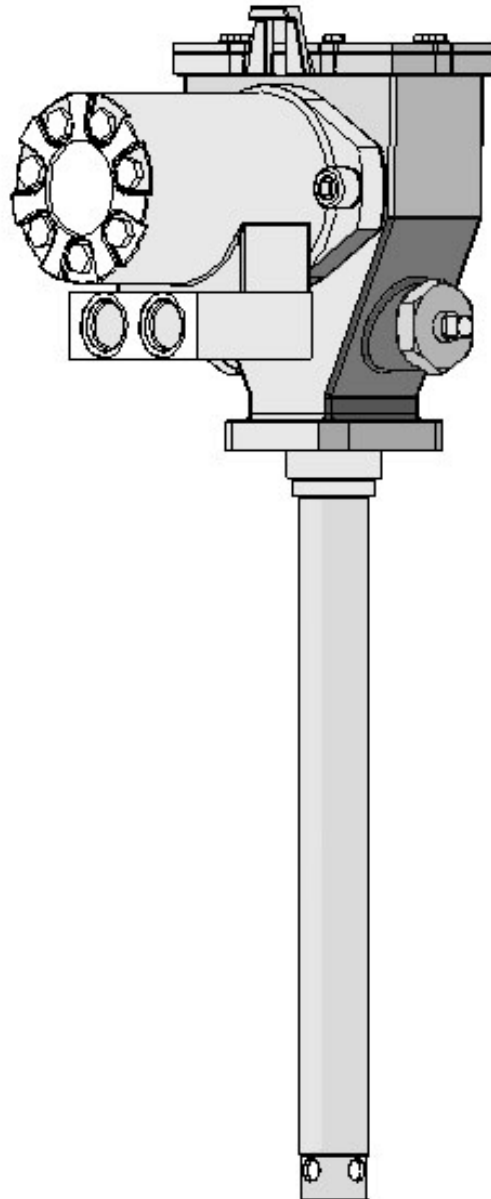

Foreign and U.S. Patent Pending

This pump conforms to the European Directive for Product Safety

## Table of Contents

	Page
Safety.....	2
Description.....	2
Appropriate Use.....	2
Pump Performance and Specifications.....	3
Installing the Pump.....	3
Operation.....	4
Maintenance and Repair.....	4
Pump Dimensions.....	5
Repair Parts List.....	7
Trouble Shooting.....	8

### Safety

Read and carefully observe these operating instructions before unpacking and operating the pump! The pump must be operated, maintained and repaired exclusively by persons familiar with the operating instructions. Local safety regulations regarding installation, operation and maintenance must be followed.

Operate this pump only after safety instructions and this service manual are fully understood.

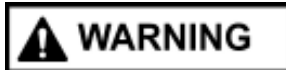

Indicates a potentially hazardous situation which, if not avoided, could result in death or serious injury.

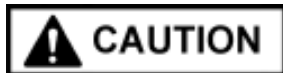

Indicates a potentially hazardous situation which, if not avoided, may result in minor or moderate injury.

### Safety Instructions

This equipment generates very high grease pressure. Extreme caution should be used when operating this equipment as material leaks from loose or ruptured components can inject fluid through the skin and into the body causing serious bodily injury. Adequate protection is recommended to prevent splashing of material onto the skin or into the eyes.

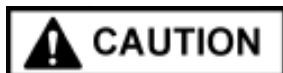

If any fluid appears to penetrate the skin, get emergency medical care immediately. Do not treat as a simple cut. Tell attending physical exactly what fluid was injected.

### Inspection

If overpressurizing of the equipment is believed to have occurred, contact the factory authorized warranty and service center nearest you for inspection of the pump.

Specialized equipment and knowledge is required for repair of this pump. Contact the factory authorized warranty and service center nearest you for repair or adjustments other than maintenance specified in this manual.

Annual inspection by the factory authorized warranty and service center nearest you is recommended.

A list of factory authorized warranty and service centers is available upon request.

### Damaged Pumps

Any pump that appears to be damaged in any way, is badly worn or operates abnormally, shall be removed from use until repairs are made. Contact the factory authorized warranty and service center nearest to you for repairs.

### Description

#### General Description

The Lincoln Industrial FlowMaster Pump Model 85486 is a fully hydraulically operated grease pump. Grease output is proportional to the hydraulic input flow. The pump is primarily designed for use in a 5 gallon pail or small container.

The pump is driven by the rotary motion of the hydraulic motor. Rotary motion is converted to reciprocating motion through an eccentric crank mechanism. The reciprocating action causes the pump cylinder to move up and down. The pump is a positive displacement **single acting pump**. Grease output occurs during the up stroke of the pump.

During the down stroke, the pump cylinder is extended into the grease. Through the combination of shovel action and vacuum generated in the pump cylinder chamber, the grease is forced into the pump cylinder. During the up-stroke, the inlet check closes, and the grease taken in during the previous stroke is transferred through the outlet check and discharged to the outlet port. Typical output of the pump is shown on page 4.

#### Appropriate Use

- The pump is exclusively designed to pump and dispense lubricants using hydraulic power.
- The maximum specification ratings should not be exceeded.
- Any other use not in accordance with instructions will result in loss of claims for warranty and liability.



Do not exceed 450 PSIG (32 bar) maximum supply inlet hydraulic pressure. Exceeding the rated pressure may result in damage to system components and personal injury.

# FlowMaster™ Rotary Driven Hydraulic Pump

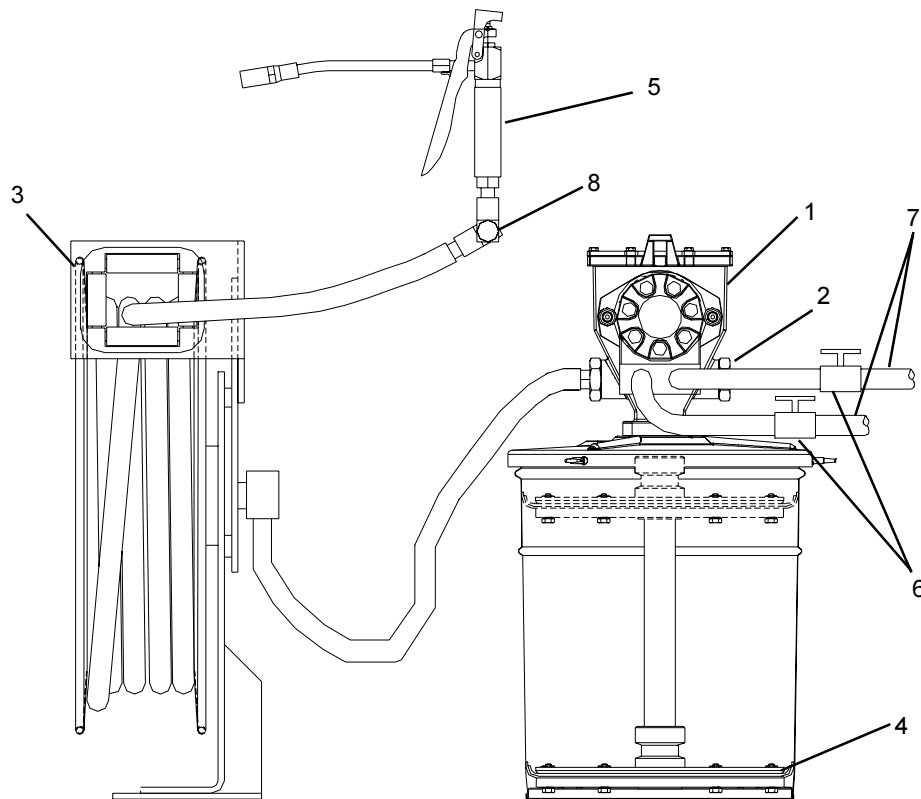

1. Pump Model 85486
2. Plug, unused outlet
3. Hose Reel
4. Follower, Model 252725
5. Control Valve
6. Shut-off Valve
7. Hydraulic Power Supply and Return
8. Swivel

**Typical Installation**

## Pump Performance and Specification

Maximum Output Pressure, PSIG (BAR)	4,5000 (320)
Supply inlet hydraulic pressure, maximum, PSIG (bar) -	450 (32)
Hydraulic Inlet Flow, GPM (l/min) -	Up to 7 (28)
Pump Ratio with manifold -	10:1
Operating Temperature, °F (°C)-	-20 to +150 (-10 to 65)
Hydraulic Inlet Port, In -	3/8 NPTF
Tank Return Port, In -	3/8 NPTF
Pump Outlets, In -	1/4 NPTF
Maximum Pump Output -	22 in <sup>3</sup> /min. * (244 grams/min)
Maximum Hydraulic Fluid Temperature, °F, (°C) -	200 (93)
Weight, Lbs (Kg) -	36 (16)
<b>Crankcase oil-</b>	<b>10 oz of API 10W30 motor oilSF-SC</b>

\* Tested with NLGI #2 grease and 1,000 PSI (68 bar) backpressure at 5 gpm (19 l/pm)

## Installing the Pump

Typical installation is shown only as a guide for selecting and installing system components. Contact your Lincoln Industrial representative for assistance in designing a system to suit your specific needs.

The pump was tested in light weight oil which was left in to protect the pump from corrosion. Flush the pump before connecting it to the system to prevent contamination of the grease with residual oil.

Use follower plate 252725 for a 35 lb (5 gallon) pail.

1. Mount the pump securely on the drum cover so that it cannot move or vibrate during operation.
2. Attach hydraulic supply line and return line to the motor ports. The pump will work in either direction.
3. Connect hose reel inlet line to the pump outlet. Plug the unused outlet on the opposite side of the pump.



Mount the pump securely on the drum cover. Failure to do so could result in personal injury and equipment damage.



Do not exceed 450 PSIG (32 bar) working hydraulic pressure. Use high pressure components to reduce risk of serious injury including fluid injection and splashing in the eyes or on the skin. All accessories connected to the pump outlet must have at least 5,000 PSIG (345 bar) minimum hydraulic pressure.

## Operation

Connect one port of the pump to a hydraulic power supply and the other to the tank line. The pump motor will run in either direction, so it makes no difference which port connects to the power supply.

1. Slowly turn on the hydraulic flow until the pump begins to run.
2. Prime the pump by slowly operating the pump until lubricant begins to flow. Make sure that all air has been expelled from the pump and even lubricant flow is achieved.
3. Adjust the pump pressure to the desired application requirements. Do not exceed pump operating pressure of 450 PSIG (32 bar).
4. Always use the lowest pump output pressure to obtain the desired results. This will reduce the pump wear.

Do not exceed maximum operating temperature of the hydraulic fluid (200° F (93° C)). Recommended minimum hydraulic fluid viscosity is 50 SUS. Never allow the pump to run dry of lubricant. A dry pump quickly speeds up, creating friction heat, which can damage the seals. Monitor the supply lubricant level and refill when necessary.

## Maintenance & Repair

Relieve pressure from the pump and supply lines before servicing or repairing the pump, to reduce the risk of an injury from injection, splashing fluid or moving parts.

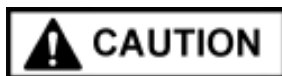

Always use Lincoln Industrial parts for service and repair.

### Disassembly Procedure (See illustration #1)

#### Tools Required:

- Hex Bit Socket Wrenches (3/8" square drive) with 3/8" hex, 5/32" hex, 1/4" hex.
- 3/8" O.D. Steel Rod
- 12" Crescent Wrench
- Spanner Wrench (for 3/8" diameter tube, 1/8" pin)
- 1/2" to 3/8" square drive adapter
- Torque wrench (1/2" square drive, 0 - 50 ft-lb capacity)
- Torque wrench (3/8" square drive, 0 - 120 in-lb capacity)
- 1/4" nut driver
- Screwdriver (flat blade, 1/8" blade width)

1. Remove the four Socket Head Screws (32) and separate Connection Manifold (33) from the Hydraulic Motor (36).
2. Remove Pipe Plug (39) and drain the crankcase oil from the Pump Housing (40).

3. Remove six self-threading Screws (29) and remove the Housing Cover (30) and the Cover Gasket (31).
4. Remove Retaining Ring (51) and pull the Shovel Plug (50) from the Housing Tube (49).
5. Remove two Socket Head Screws (38) and separate the Hydraulic Motor (36) from the Pump Housing (40).
6. Remove two Outlet Pin Nuts (44) from the Pump Housing (40).
7. Remove the Pump Subassembly (1 through 28) from the Pump Housing (40). Pushing the subassembly up with a wooden or plastic rod 3/4 O.D. against the Check Seat Housing (28) is helpful.
8. Remove the Housing Tube (49) from the Pump Housing (40) by inserting a 3/4 rod through the inlet holes at the bottom of the Housing Tube (49) and unscrewing it.
9. Remove the Bronze Bearing (45), the O-Ring (46), and the Backup Washer (47) from the Housing Tube (49).
10. Remove the Crankrod Assembly (1 through 8) from the pump by unscrewing the Button Head Screws (12) and then pulling out the Wrist Pin Bushings (13).
11. Remove the Check Seat Housing (28) from the Reciprocating Tube (21). There is a 3/8 Allen Head socket in the throat of the Check Seat Housing (28) to facilitate removal.
12. Unscrew the Wrist Pin Anchor (14) from the Reciprocating Tube (21) and pull the Plunger Assembly (9 through 20) from the tube.
13. Using a 1/2" dia. wooden or plastic rod, push the Cup Seal (22) and the Pump Cylinder (24) from the Reciprocating Tube (21).
14. Remove the Pump Plunger (20) from the Plunger Link Rod (17). A spanner wrench, which uses the holes in the Pump Plunger, is required.
15. Unscrew the Plunger Link Rod (17) from the Plunger Tube (11) and slide off the Cup Seal (16), the Backup Washer (15) and the Wrist Pin Anchor (14).
16. Unscrew the Plunger Tube (11) from the Outlet Pin (9).
17. To dismantle the Crankrod Assembly (1 through 8), remove Flat Head Screws (1) and the Inner and Outer Weights (2 & 3).
18. Remove the large Retaining Rings (6) and press the Ball Bearing Assembly (6, 7, 8) out of the Crank Rod (5). Be sure to press the Ball Bearing (8) on the outer race.
19. Remove the small Retaining Rings (6) and press the Crank Eccentric (7) out of the Ball Bearing (8). Be sure to support the Ball Bearing (8) on the inner race.

### Pump Assembly Procedure

1. When the pump is disassembled, it is recommended to replace all seals and gaskets, which are included in the repair kit.
2. In the process of disassembly, examine the following components and replace if excessive wear is indicated: Ball Bearing (8), Crank Eccentric (7), Crankrod (5), Wrist Pin Bushings (13), Plunger Tube (11), Pump Plunger and Upper Check Parts (20, 19 and 18), Pump Cylinder (24), Check Seat Housing and Lower Check Balland seat (28 and 26), upper Bronze Bushing (45), Housing Tube (49),

# FlowMaster™ Rotary Driven Hydraulic Pump



Shovel Plug (50), and Reciprocating Tube (21).

3. Assembly Procedure is the reverse of the Disassembly Procedure except for the following:
4. Install parts (22) through (28) into the Reciprocating Tube (21) after the plunger assembly (9 through 20) is installed.
5. Install the Pump Subassembly (1 through 28) into the pump Housing (40) before tightening the Housing Tube (49) to the Pump Housing (40). Be sure the Reciprocating Tube (21) is inserted through both bushings before tightening the Housing Tube (49).
6. Use loctite 242 (or similar product) medium strength thread lock on all torqued threaded connections. Extreme care must be exercised to prevent excess compound from flowing into critical areas such as clearance fits and ball check. Allow a minimum of 30 minutes cure time before operating the pump.
7. Fill crankcase with 10W30 motor oil up to the bottom of the pipe plug (39).

### Torque Specifications:

- A. Plunger Tube (11) to Outlet Pin (9) - 100 to 110 In.-Lbs.
- B. Button Head Screws (12) to Wrist Pin Anchor (14) 100 to 110 In.-Lbs.
- C. Plunger Tube (11) to Plunger Link Rod (17) - 100 to 110 In.-Lbs.
- D. Plunger Link Rod (17) to Pump Plunger (20) - 100 to 110 In.-Lbs.
- E. Flat Head Screws (1) to Outer Weight (2) - 100 - 110 In.-Lbs.
- F. Wrist Pin Anchor (14) to Reciprocating Tube (21) - 20 to 25 Ft.-Lbs.
- G. Check Seat Housing (28) to Reciprocating Tube (21) - 20 to 25 Ft.-Lbs.
- H. Outlet Pin Nut (44) to Pump Housing (40) - 30 to 35 Ft.-Lbs.
- I. Housing Tube (49) to Pump housing (40) - 20 to 25 Ft.-Lbs.

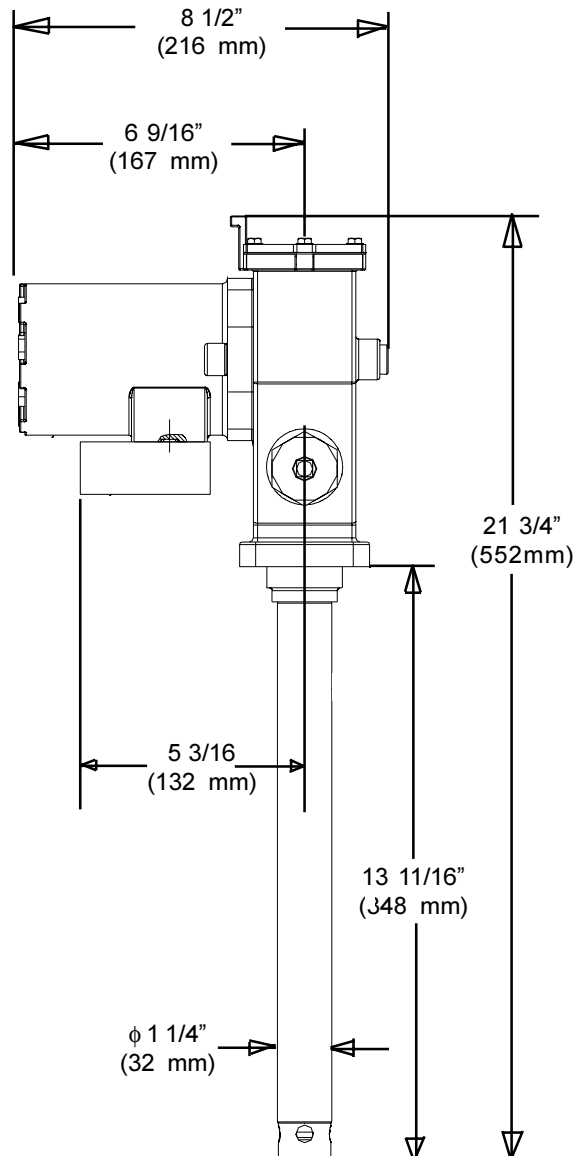
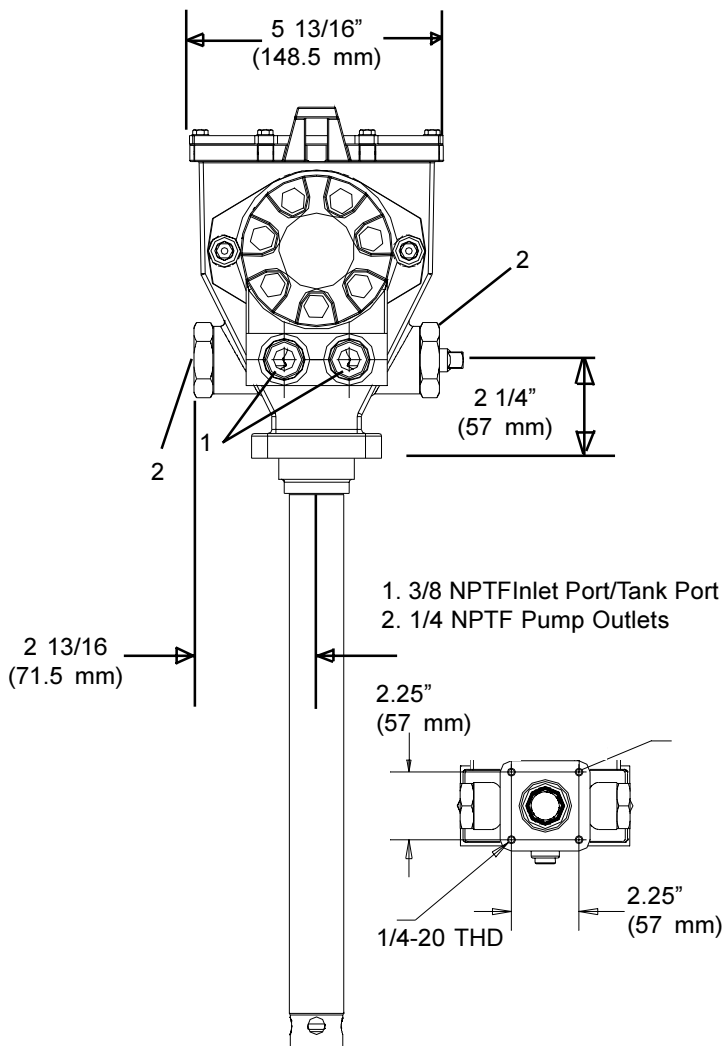

# FlowMaster™ Rotary Driven Hydraulic Pump

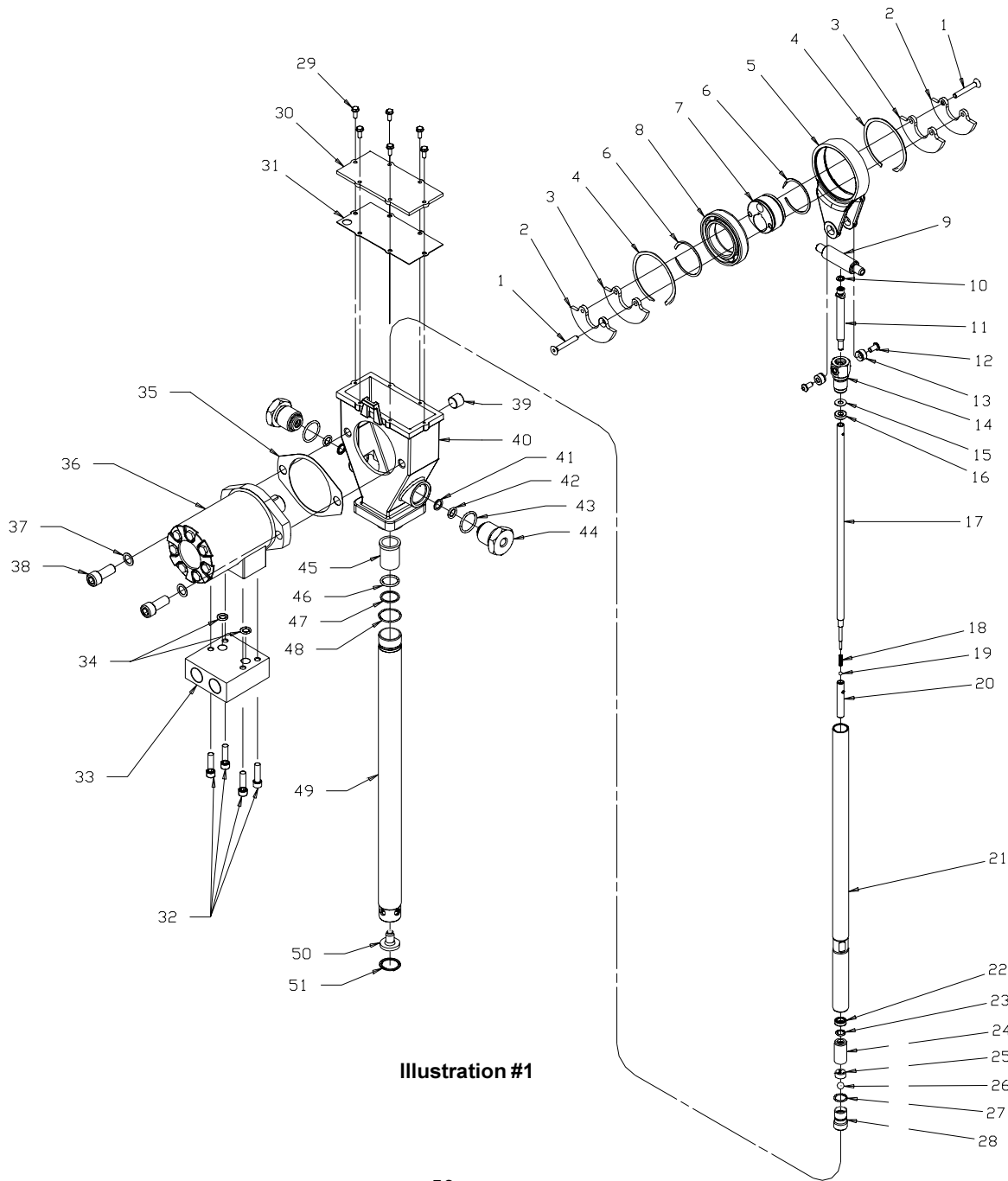
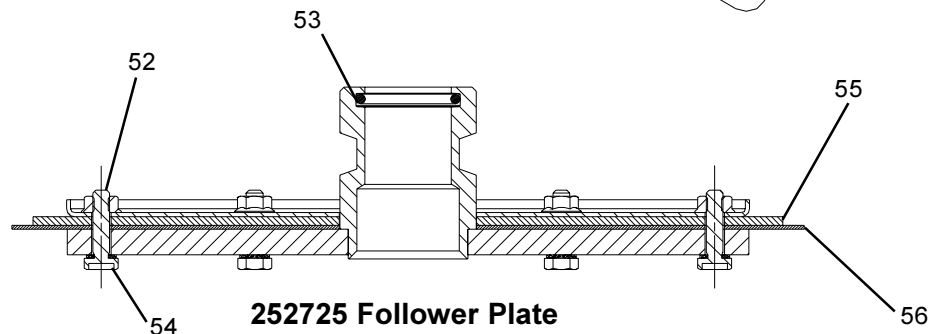

Illustration #1



252725 Follower Plate

Illustration #2

## Repair Parts List (Common to all Models)

Item No.	Qty	Description	All Models
1.	2	Flat Head Screw (1/4 x 1-3/4)	270635
2.	2	Outer Weight	270606
3.	2	Inner Weight	270605
4.	2	Retaining Ring	270609
5.	1	Crankrod	270665
6.	2	Retaining Ring	270608
7.	1	Crank Eccentric	270727
8.	1	Ball Bearing	270607
9.	1	Outlet Pin	270670
10.	1	O-Ring (Nitrile)	*
11.	1	Plunger Tube	270729
12.	2	Button Head Screw (1/4 x 1/2)	270634
13.	2	Wrist Pin Bushing	270668
14.	1	Wrist Pin Anchor	270731
15.	1	Backup Washer	*
16.	1	Cup Seal (Polyurethane)	*
17.	1	Plunger Link Rod	270728
18.	1	Spring	270616
19.	1	Ball	66010
20.	1	Pump Plunger	270671
21.	1	Reciprocating Tube	270642
22.	1	Cup Seal (Polyurethane)	*
23.	1	O-Ring (Polyurethane)	*
24.	1	Pump Cylinder	270672
25.	1	Ball Cage	270675
26.	1	Ball	66001
27.	1	O-Ring (Nitrile)	*

Item No.	Qty	Description	All Models
28.	1	Check Seat	270664
29.	6	Self-Threading Screw (8 x 1/2)	270633
30.	1	Housing Cover	270629
31.	1	Cover Gasket (Nitrile)	*
32.	4	Socket Head Screw (5/16 x 1-1/4)	270680
33.	1	Manifold	270770
34.	2	O-Ring (Nitrile)	*
35.	1	Motor Gasket	*
36.	1	Hydraulic Motor (Note #1)	270676
37.	2	Washer	48548
38.	2	Socket Head Screw (1/2 x 1-1/4)	270658
39.	1	Pipe Plug (3/8 NPTF)	67417
40.	1	Pump Housing	270673
41.	2	Backup Ring (Nitrile)	*
42.	2	O-Ring (Nitrile)	*
43.	2	O-Ring (Nitrile)	*
44.	2	Outlet Pin Nut	270619
45.	1	Bronze Bearing	270674
46.	1	O-Ring (Nitrile)	*
47.	1	Backup Washer	*
48.	1	O-Ring (Nitrile)	*
49.	1	Housing Tube	270662
50.	1	Shovel Plug	270730
51.	1	Retaining Ring	270705
52.	6	Nut	51412
53.	1	O-Ring	249692
54.	6	Bolts	249693
55.	1	Seal	249688
56.	1	Seal	249687
		Soft parts Kit	249832

\* Included in 249832 Soft Parts Kit.

1. Includes Gasket (Item 35) and O-Rings (Item 34).

## Troubleshooting

Condition	Possible Cause	Corrective Action
Pump does not run.	Closed supply line shut off valve.	Open shut-off valve.
	Insufficient Hydraulic Fluid supply.	Check hydraulic supply for proper pressure and flow.
	Closed fluid outlet line.	Check outlet line and clear obstructions.
	Pump is stalled due to grease backpressure.	Relieve grease backpressure.
	Pump is seized or damaged.	Dismantle the pump and repair defective or seized component. See disassembly and assembly procedure.
Pump speeds up or runs erratically.	Low level of grease or reservoir is empty.	Refill reservoir.
	Follower plate is stuck and separated from grease.	Check follower plate and container for damage.
	Pump piston or checks are worn.	Disassemble the pump and repair.
Pump runs, but output is low.	Insufficient hydraulic fluid supply.	Check hydraulic supply and adjust flow.
	Inlet pressure too low.	Increase pressure using valve 38.
Weepage from housing cover 30.	Cup seal (16) or O-Ring (48) failure.	Check the seals and replace if necessary.
Pump becomes noisy.	No crank case oil.	Add crank case oil. Remove Pipe Plug (39) from Pump Housing (40). Oil level should be at the bottom of the Pipe Plug opening. Add 10W30 motor oil until the crankcase is full.
	Worn wrist pin bushing 13.	Check the bushings and replace if necessary.

**Americas:**  
 One Lincoln Way  
 St. Louis, MO 63120-1578  
 USA  
 Phone +1.314.679.4200  
 Fax +1.800.424.5359

**Europe/Africa:**  
 Heinrich-Hertz-Str 2-8  
 D-69183 Walldorf  
 Germany  
 Phone +49.6227.33.0  
 Fax +49.6227.33.259

**Asia/Pacific:**  
 25 Int'l Business Park  
 #01-65 German Centre  
 Singapore 609916  
 Phone +65.562.7960  
 Fax +65.562.9967



**A Pentair Company**

© Copyright 1999  
 Printed in USA  
 Web site:  
[www.lincolnindustrial.com](http://www.lincolnindustrial.com)