

SPECIFICATIONS

Height of unit in lowered position - 73"
Height of unit in raised position - 110-1/2"
Hoist capacity - 400 lbs.
Operating air pressure - 40 psi Min., 200 psi Max.

**400 LB. DRUM SIZE
AIR OPERATED - MANUALLY CONTROLLED**

MODEL 1716

FOR USE WITH ALL
1900 SERIES POWER-
MASTER PUMPS.

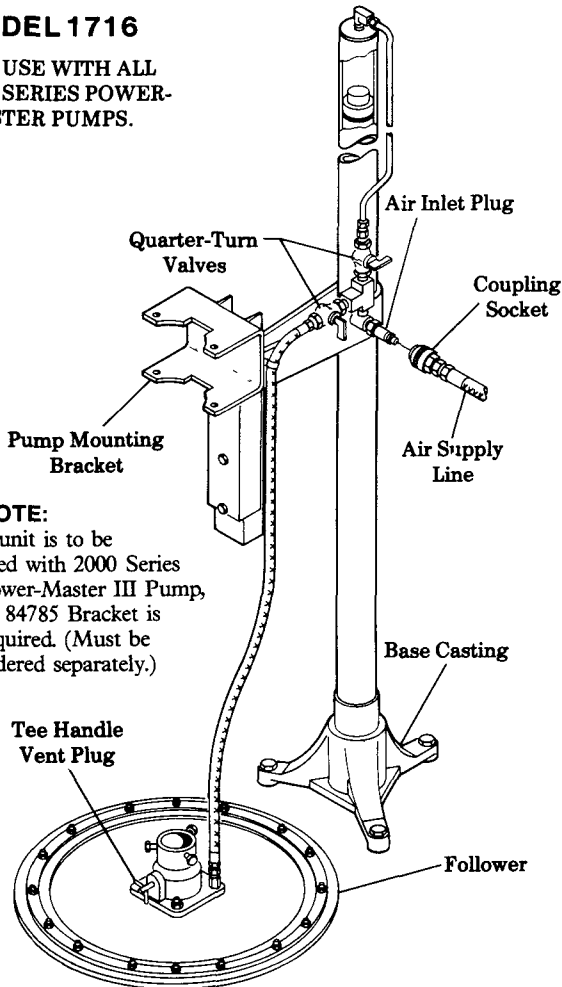

NOTE:
If unit is to be used with 2000 Series Power-Master III Pump, an 84785 Bracket is required. (Must be ordered separately.)

MODEL 1719

FOR USE WITH ALL
2100 AND 2200 SERIES
PILE DRIVER PUMPS.

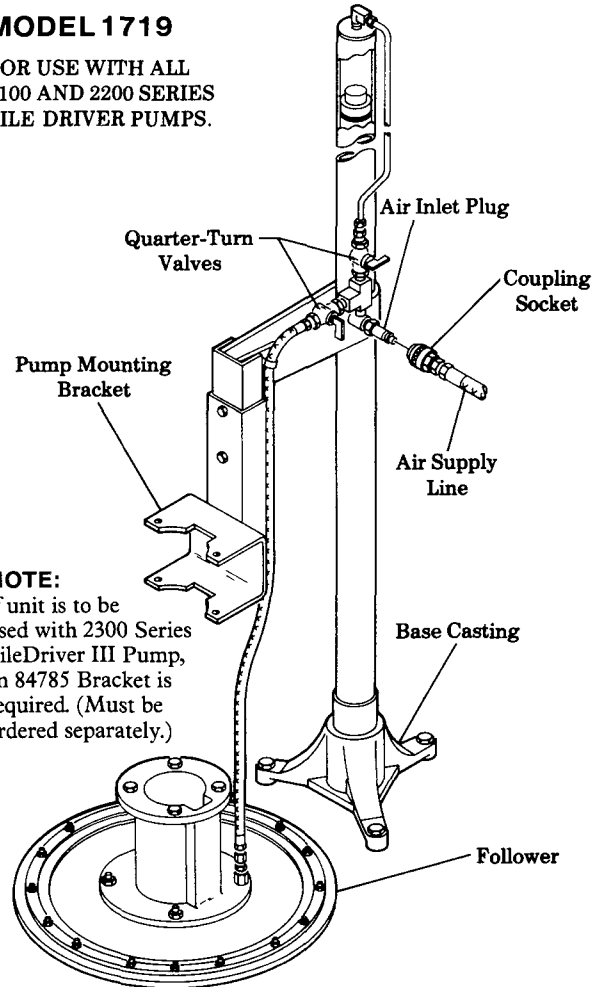

NOTE:
If unit is to be used with 2300 Series PileDriver III Pump, an 84785 Bracket is required. (Must be ordered separately.)

INSTALLATION

The base casting can be used as a template to mark the location of anchor bolts.

Two or three drums can be positioned around the hoist for rapid changing of pump from one drum to another. Hoist rotates 360°.

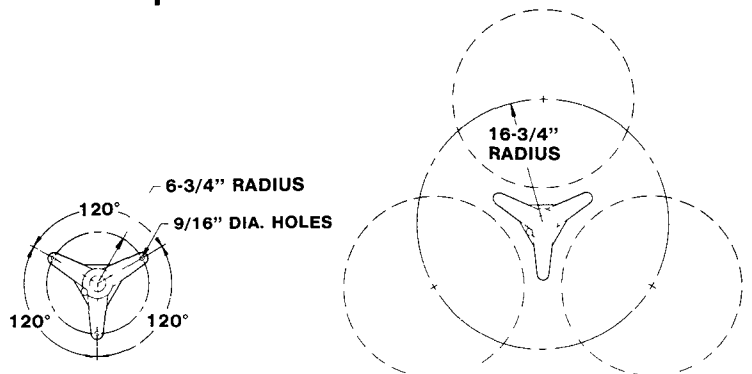

SERVICE PARTS

Part	Qty.	Description	Part	Qty.	Description
10130	1	Nipple	50524	1	Set screw
15858	1	Spacer	50625	1	Screw
16362	1	Adapter	51001	2	Nut
16397	2	Screw	51010	18	Nut
31029	2	Gasket	51014	6	Nut
33072	1	Gasket	51039	4	Nut
33088	1	Gasket	51300	1	Nut
33100	1	Gasket	62338	1	Tube
34327	1	Packing (Buna-N)	66414	1	Tube connector
34337	2	O-ring (Buna-N)	66415	1	Tube connector
34371	1	Wiper (Buna-N)	66649	1	Adapter union
40446	1	Tube cap	67011	1	Pipe tee
40447	1	Tube cap	67063	1	Pipe coupling
40492	1	Follower casting	67321	1	Nipple
40494	1	Base casting	68740	2	Air cock
40607	1	Follower casting	82238-48	1	Air hose
48019	10	Washer	83286	1	Follower assembly
48429	1	Wiper ring	83793	1	Follower assembly
48514	1	Wiper ring	83798	1	Pump hoist
50002	5	Screw	83995	1	Line check
50016	3	Screw	91632	1	Support tube
50018	18	Screw	91796	1	Tee handle plug
50038	2	Screw	92284	1	Support tube
50122	3	Screw	93381	1	Support bracket
50178	2	Screw	236535	1	Viton packing
50179	2	Screw	360108	1	Tube clip
50180	4	Screw	653106	1	Plug
50505	1	Set screw			

Airmotor	82737	82895	82730	82736	83435
Screw	50179	50178	50178	50179	50179

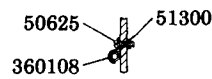

SECTION A-A

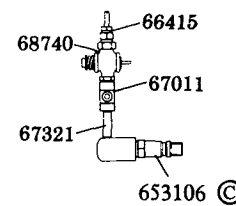

SECTION B-B

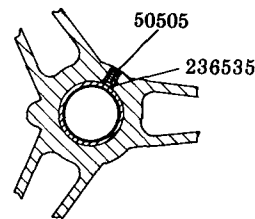

SECTION C-C

Refer to Service Manual-
Section K4, Page 1 Series
for Low Level Air Cutoff Kits.

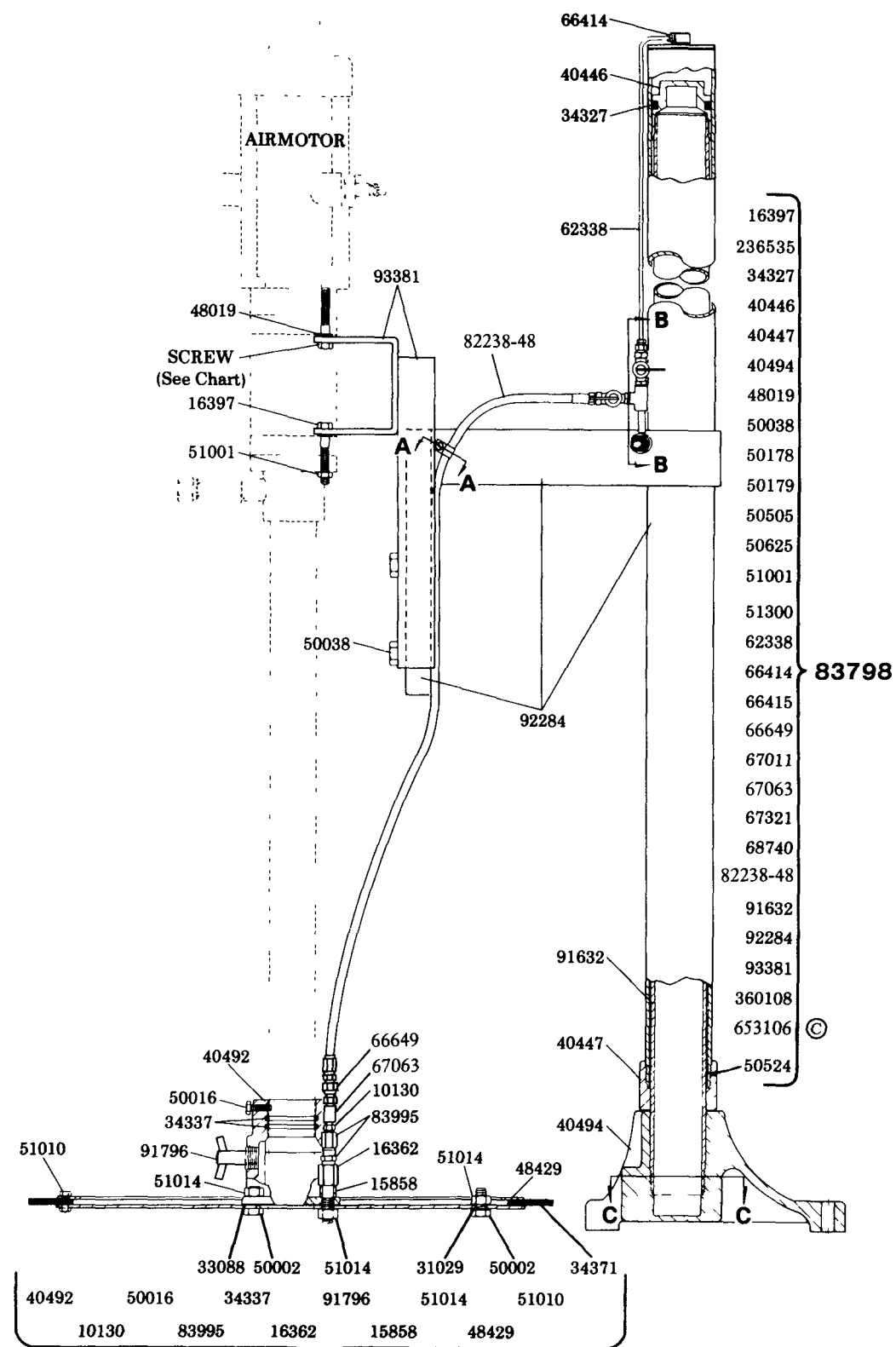

83286

MODEL 1716

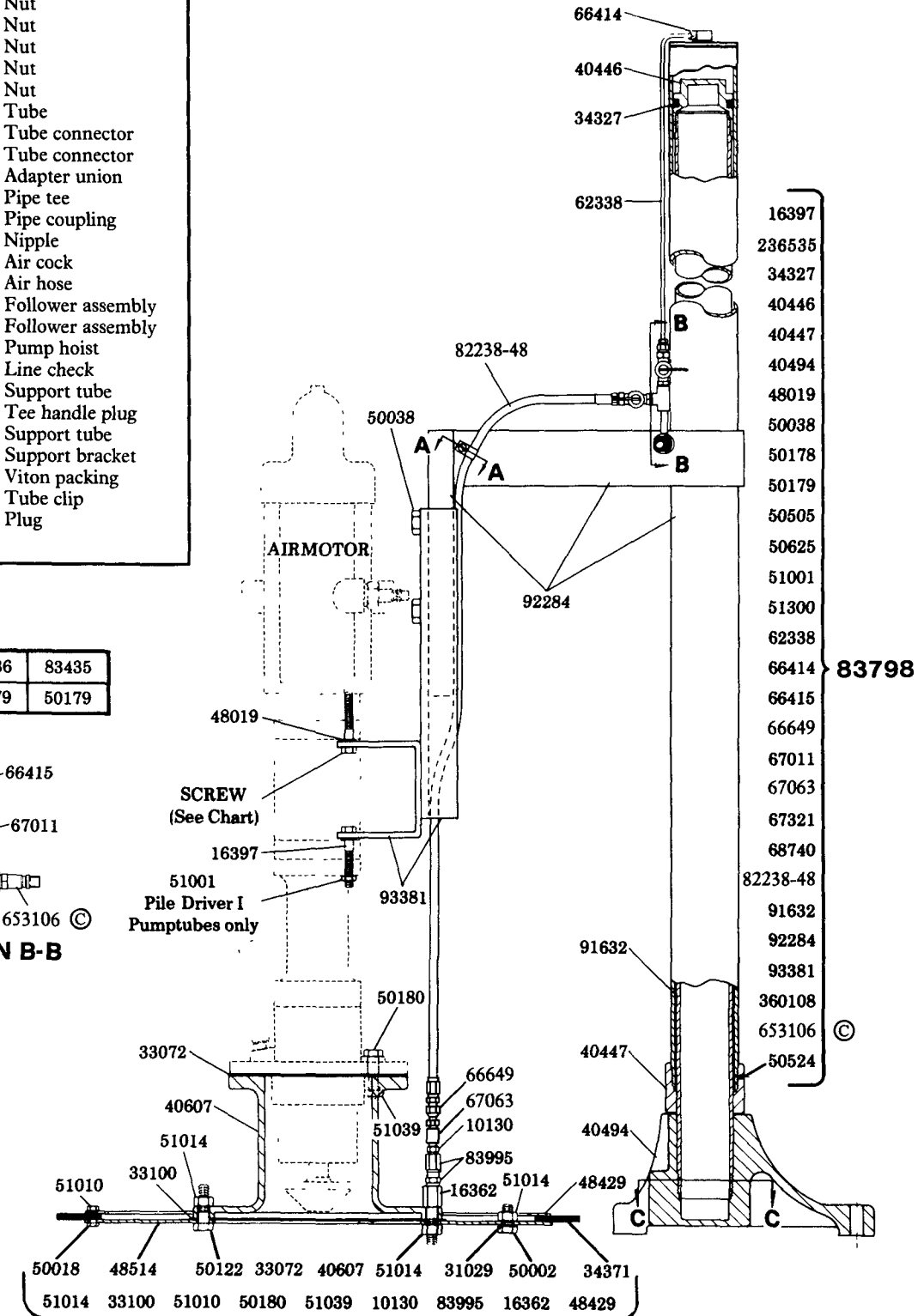

83793

MODEL 1719

© Indicates Change

INSTALL PUMP TO MOUNTING BRACKET

Remove the four hex head screws from the side of the airmotor opposite the name plate. Place the pump mounting bracket between the flanges of the airmotor support casting. Using the screws included with hoist, fasten the mounting bracket to the airmotor. Eight 48019 Washers are included as shims for use between the mounting bracket and bottom flange of the airmotor support casting.

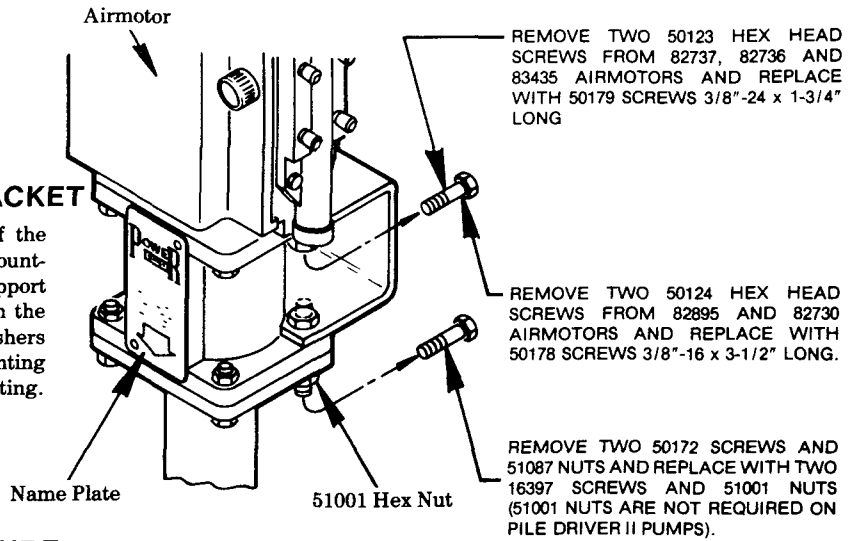

TO INSTALL FOLLOWER TO PUMPTUBE

Model 1716 (For Series II Power-Master Pumps)

Loosen the three 50016 Set Screws sufficiently to allow the follower to be slipped onto the pumptube. Tighten the set screws to hold the follower in place.

Model 1719 (For Series II PileDriver Pumps)

Bolt the follower to the flange of the pumptube with the four 50180 Screws and 51039 Nuts. Tighten securely.

OPERATION OF HOIST

To raise hoist:

- 1) Remove air coupler from the pump and connect to air inlet plug of the hoist.
- 2) Open quarter-turn valves on hoist. Air flow directed to top of hoist raises hoist, pump and follower as a unit. Air directed to follower assists by breaking the seal between the follower and the drum, exerting pressure up on the follower and down on the drum.
- 3) Shut off valve to the top of the hoist and disconnect air coupler to hold hoist in raised position.

To lower pump and follower into drum (air supply line must be disconnected):

- 1) Open air valve to top of hoist. The valve controls the speed of descent of the hoist. Close the valve before follower contacts top of drum.
- 2) Position drum to allow follower entry.
- 3) Lower pump and follower slowly into drum.
- 4) Open valve fully to permit weight of pump and follower to seat follower onto material in the drum. NOTE: Remove the tee handle plug (on Model 1716) or the probe assembly (on Pile Driver Pumps) to expel air trapped beneath the follower when seating. Replace before operating pump.

TO PRIME PUMP

Open the bleeder plug in the pump outlet and operate pump until material flows from the plug opening. Shut off pump and tighten bleeder plug. Operate pump and open control valve at end of delivery hose until material flows freely from control valve. Pump is then fully primed.

MATERIAL AGITATION

Some materials pumped with Pile Driver Pumps may require agitation. Remove the bleeder valve from the pump outlet body and the plug from the adapter plate casting. Install a shut-off valve in the pump outlet body and a connecting hose from the valve to the adapter plate casting as illustrated.

To agitate material, open valve and operate pump with control valve closed. Shut-off valve is to be closed when dispensing material.

