

SPECIFICATIONS

Height of unit in lowered position - 73"
Height of unit in raised position- 110-1/2"
Hoist capacity- 400 lbs.
Operating air pressure 40 psi Min., 200 psi Max.

400 LB. DRUM SIZE

AIR OPERATED - MANUALLY CONTROLLED

MODEL 1716 & 2716

**FOR USE WITH
POWERMASTER PUMPS
(REFER TO APPLICATION
CHART)**

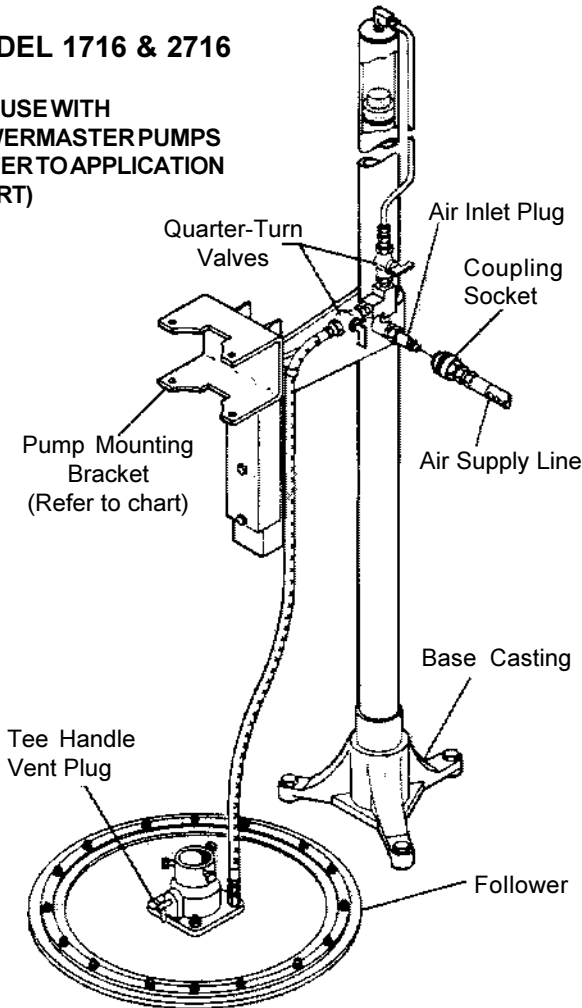

MODEL 1716 ILLUSTRATED

MODEL 1719 & 2719

**FOR USE WITH
PILE DRIVER PUMPS
(REFER TO APPLICATION
CHART)**

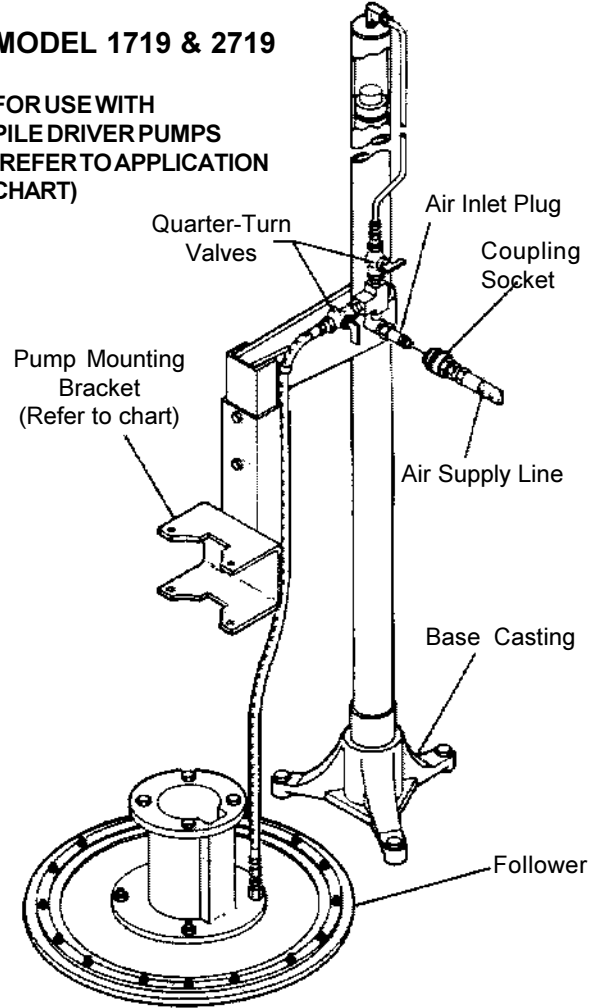

MODEL 1719 ILLUSTRATED

INSTALLATION

The base casting can be used as a template to mark the location of anchor bolts.

Two or three drums can be positioned around the hoist for rapid changing of pump from one drum to another. Hoist rotates 360°.

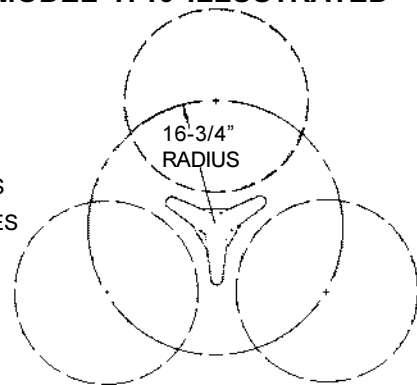
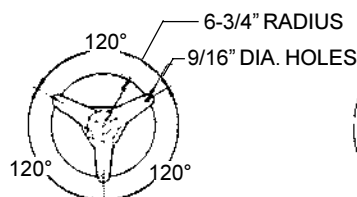

**Model Nos. 1716, 1719,
2716, 2719 PUMP HOIST**

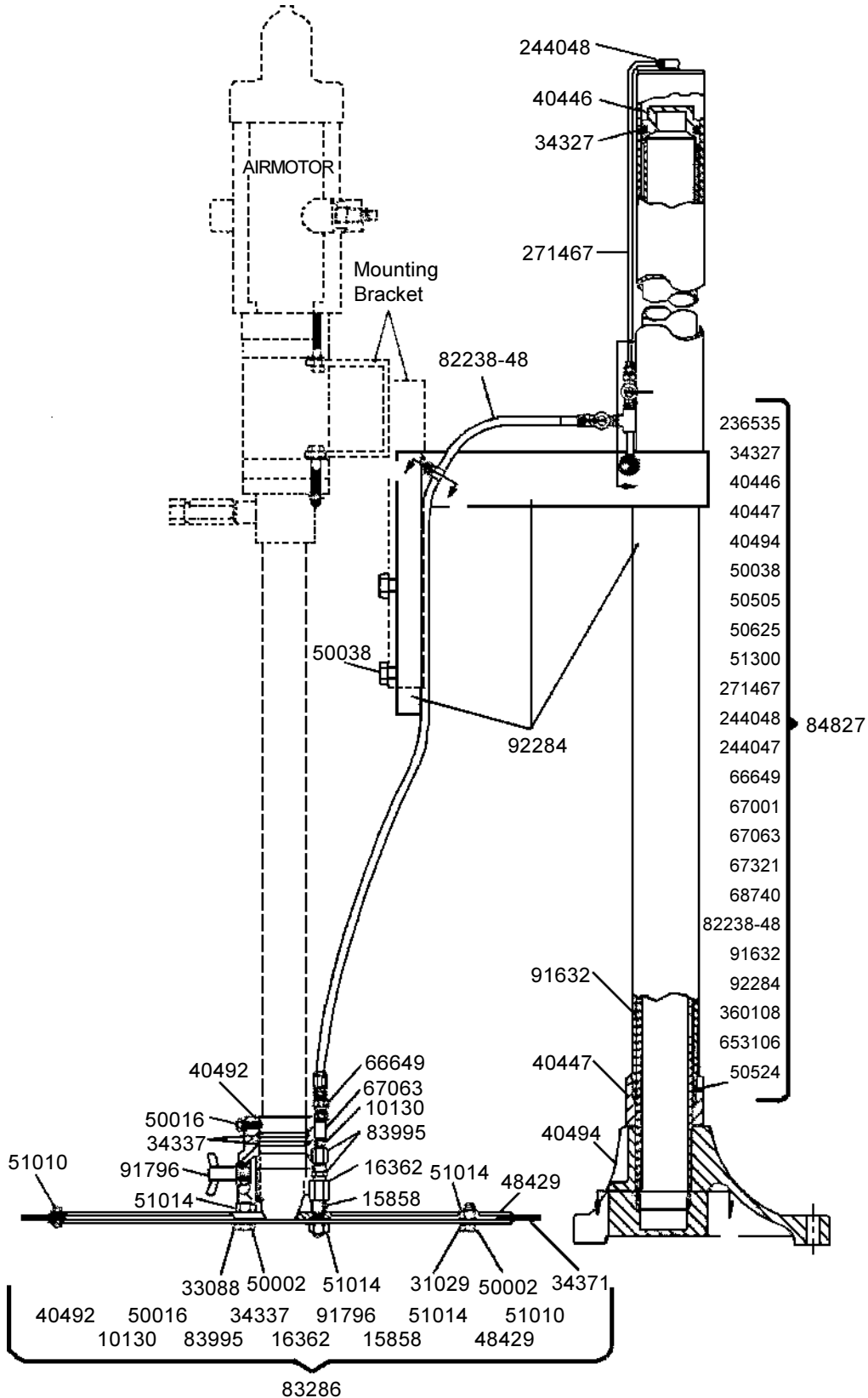

Model Nos. 1716, 1719, 2716, 2719 PUMP HOIST



SERVICE PARTS

Part	Qty.	Description	Part	Qty.	Description
10130	1	Nipple	50625	1	Screw
15858	1	Spacer	51010	18	Nut
16362	1	Adapter	51014	6	Nut
31029	2	Gasket	51039	4	Nut
33072	1	Gasket	51300	1	Nut
33088	1	Gasket	66649	1	Adapter union
33100	1	Gasket	67011	1	Pipe tee
34327	1	Packing	67063	1	Pipe coupling
34337	2	O-ring (Buna-N)	67321	1	Nipple
34371	1	Wiper (Buna-N)	68740	2	Air cock
40446	1	Tube cap	83286	1	Follower assembly
40447	1	Tube cap	83793	1	Follower assembly
40492	1	Follower casting	83995	1	Line check
40494	1	Base Casting	84827	1	Pump hoist
40607	1	Follower casting	91632	1	Support tube
48429	1	Wiper ring	91796	1	Tee handle plug
48514	1	Wiper ring	92284	1	Support tube
50002	5	Screw	236535	1	Viton packing
50016	3	Screw	244047	1	Tube connector
50018	18	Screw	244048	1	Tube connector
50038	2	Screw	271467	1	Tube
50122	3	Screw	360108	1	Tube clip
50180	4	Screw	653106	1	Plug
50505	1	Set screw	82238-48	1	Air hose
50524	1	Set screw			

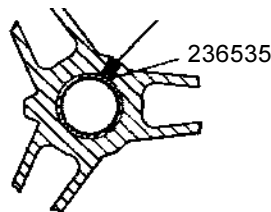
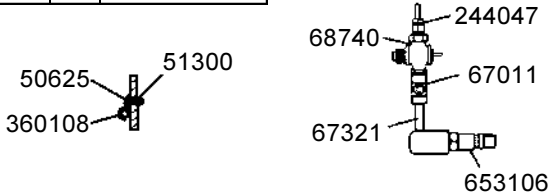

Refer to Service Manual -
Section K4, Page 1 Series for
Low Level Air Cutoff Kits.

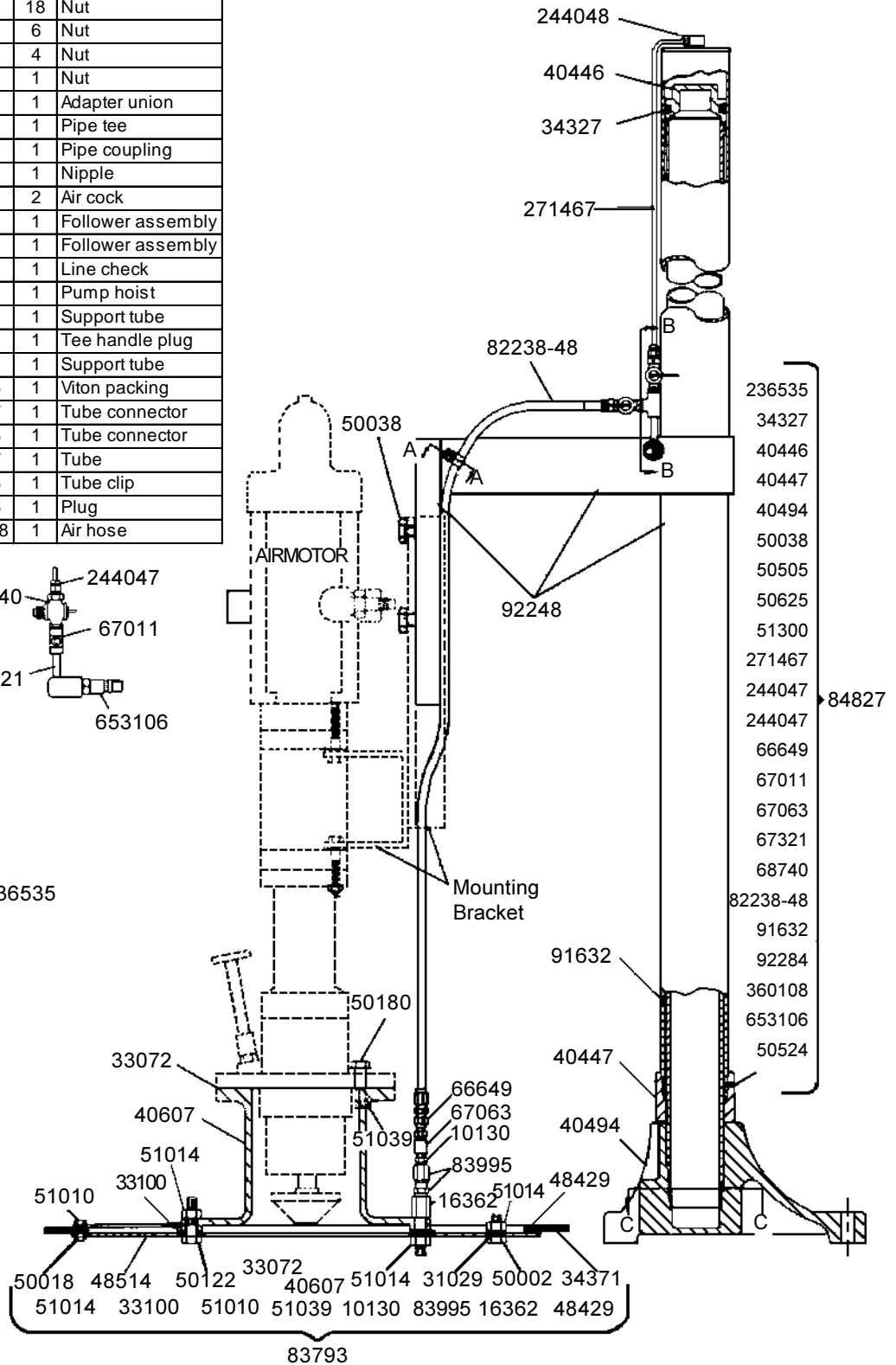

Model Nos. 1716, 1719, 2716, 2719 PUMP HOIST



APPLICATION CHART

Models	Pump Tube Application	Pressure Primer	Follower	Mounting Bracket
1716	PowerMaster	84827	83286	84391
2716	PowerMaster III	84827	83286	84785
1719	Pile Driver II	84827	83793	84391
2719	Pile Driver III	84827	83793	84785

TO INSTALL FOLLOWER TO PUMPTUBE

Model 1716 (For Series II PowerMaster Pumps) & Model 2716 (For Series III PowerMaster Pump).

Loosen the three 50016 Set Screws sufficiently to allow the follower to be slipped onto the pumptube. Tighten the set screws to hold the follower in place.

Model 1719 (For Series II Pile Driver Pumps) & Model 2719 (For Series III Pile Driver Pumps)

Bolt the follower to the flange of the pumptube with the four 50180 Screws and 51039 Nuts. Tighten securely.

OPERATION OF HOIST

To raise hoist:

- 1) Remove air coupler from the pump and connect to air inlet plug of the hoist.
- 2) Open quarter-turn valves on hoist. Air flow directed to top of hoist raises hoist, pump and follower as a unit. Air directed to follower assists by breaking the seal between the follower and the drum, exerting pressure up on the follower and down on the drum.
- 3) Shut off valve to the top of the hoist and disconnect air coupler to hold hoist in raised position.

To lower pump and follower into drum (air supply line must be disconnected):

- 1) Open air valve to top of hoist. The valve controls the speed of descent of the hoist. Close the valve before follower contacts top of drum.
- 2) Position drum to allow follower entry.
- 3) Lower pump and follower slowly into drum
- 4) Open valve fully to permit weight of pump and follower to seat follower onto material in the drum. NOTE: Remove the tee handle plug (on Model 1716 & 2716) or the probe assembly (on Pile Driver Pumps) to expel air trapped beneath the follower when seating. Replace before operating pump.

TO PRIME PUMP

Open the bleeder plug in the pump outlet and operate pump until material flows from the plug opening. Shut off pump and tighten bleeder plug. Operate pump and open control valve at end of delivery hose until material flows freely from control valve. Pump is then fully primed.

MATERIAL AGITATION

Some materials pumped with Pile Driver Pump may require agitation. Remove the bleeder valve from the pump outlet body and the plug from the adapter plate casting. Install a shut-off valve in the pump outlet body and a connecting hose from the valve to the adapter plate casting as illustrated.

To agitate material, open valve and operate pump with control valve closed. Shut-off valve is to be closed when dispensing material.

