

(FOR 400 LB. DRUM)

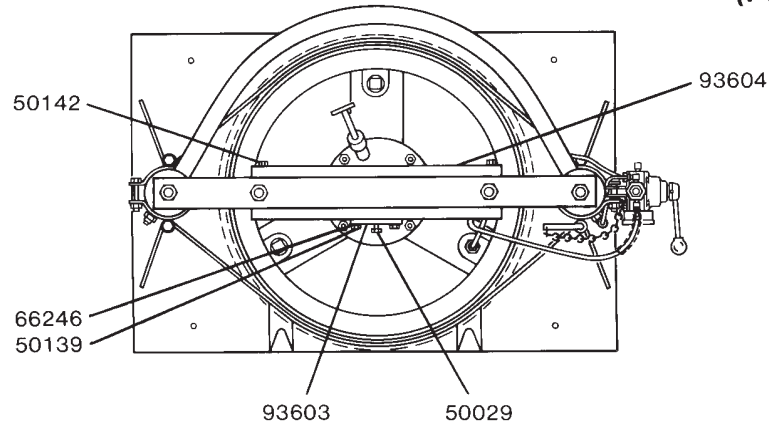

SPECIFICATIONS

HEIGHT: "Down" position, 66-1/8"
"Up" position, 103"
Maximum travel: 36-7/8"
Air pressure: 150 psi, max.
Base dimensions: 36" x 24"

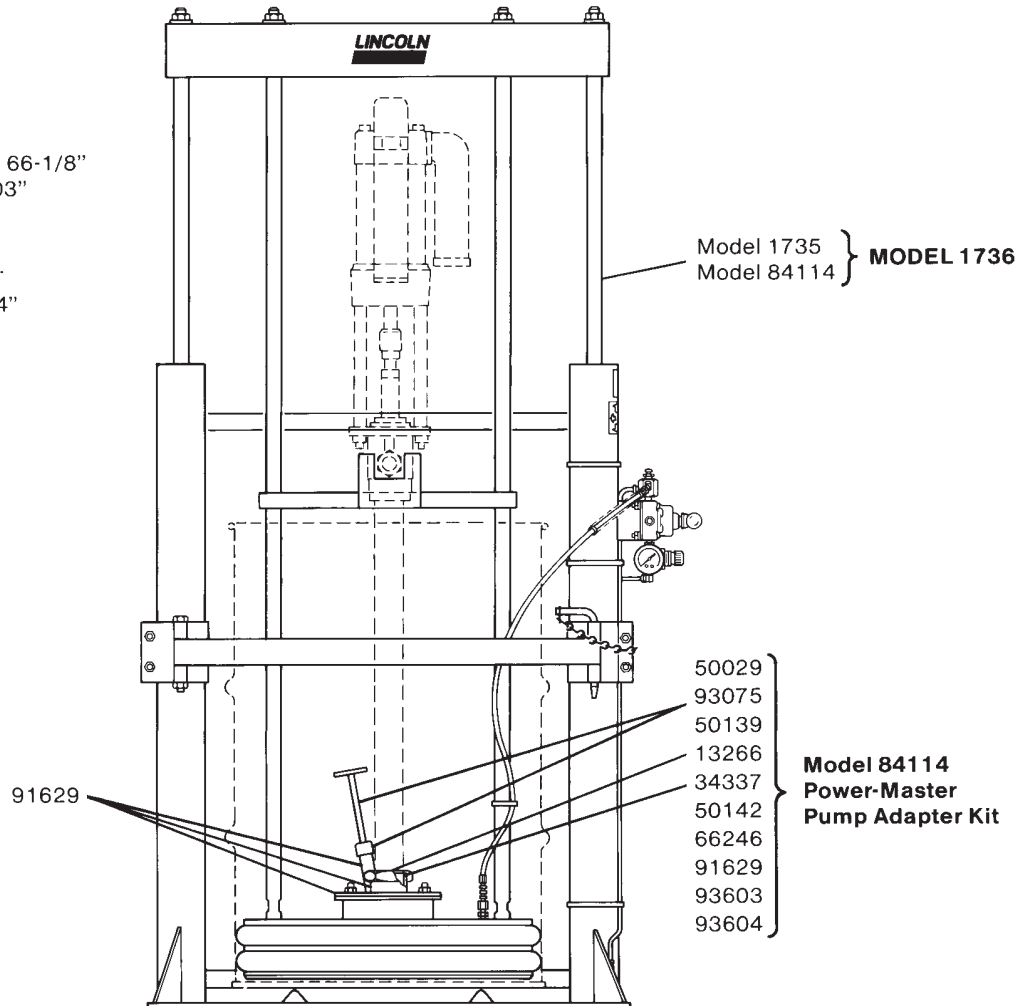

Model 1736

400 LB. PRESSURE PRIMER FOR POWER-MASTER PUMPS

Models 1735 and 1736 Twin Post Pressure Primers provide priming assistance when dispensing highly viscous materials. The follower rings prevent material from extruding past the follower and also wipe the container wall clean, even past rolled chime areas or slightly dented surfaces.

The twin post pressure primer consists of a flat steel base plate welded to twin air cylinders whose piston rods attach overhead to a channel. A

400 lb. drum follower assembly is supported by two tie rods attached to the channel. Two semi-circular straps, providing 22 3/4" clearance, secure the drum and are hinged to allow drum exchanges.

Vertical movement is controlled by a four-way air valve and an exhaust restrictor which limits the rate of travel. **Directly above the four-way valve is a pushbutton air valve which, when depressed, directs air to the underside of the follower to assist in its withdrawal from the drum.**

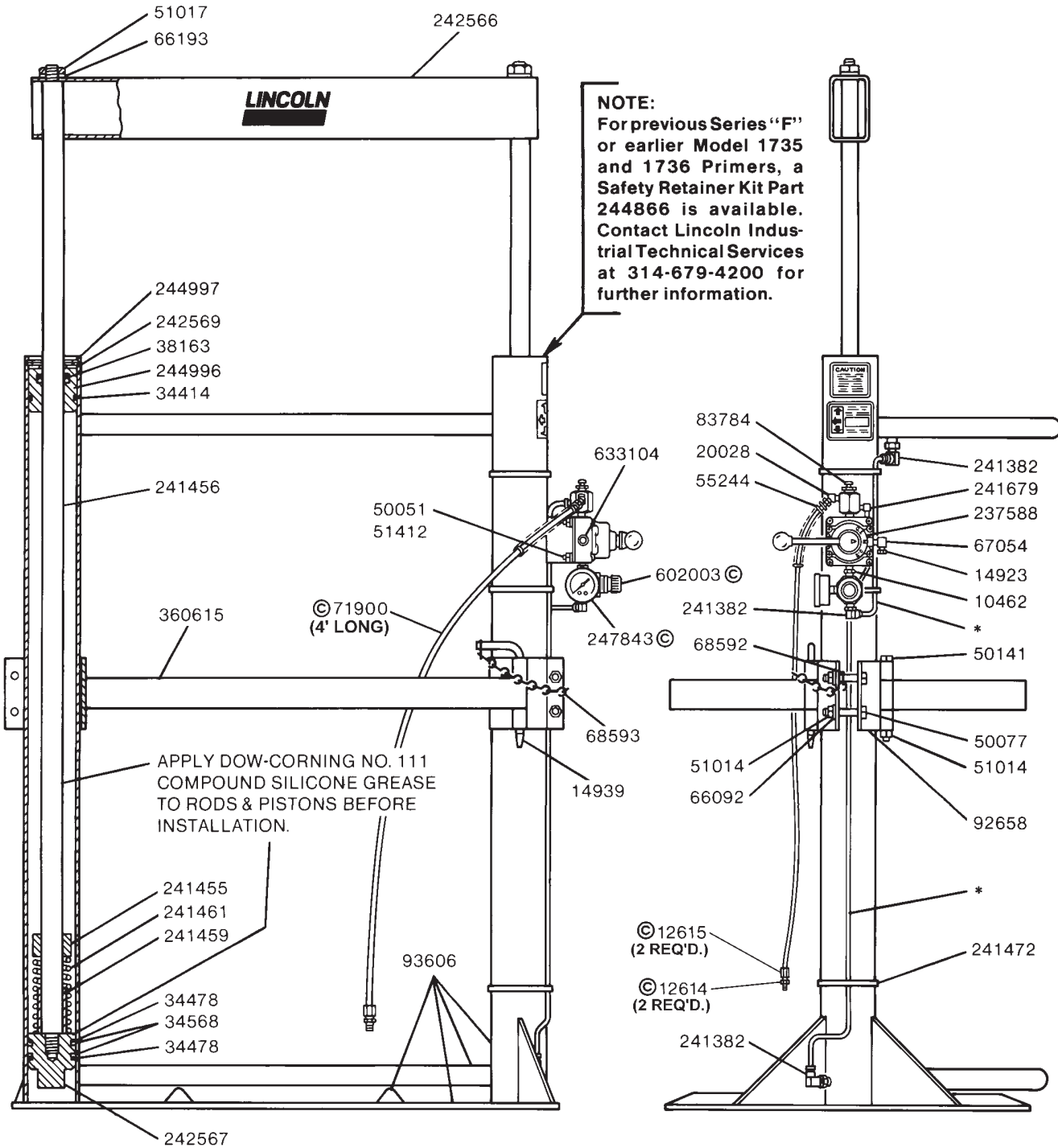

* 1/4" O.D. x .062" wall, polyethylene tubing.
Min. burst pressure - 400 psi.
Min. working pressure - 150 psi.
Cut to required length.

BASIC PRESSURE PRIMER

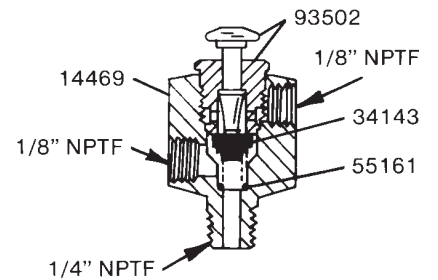
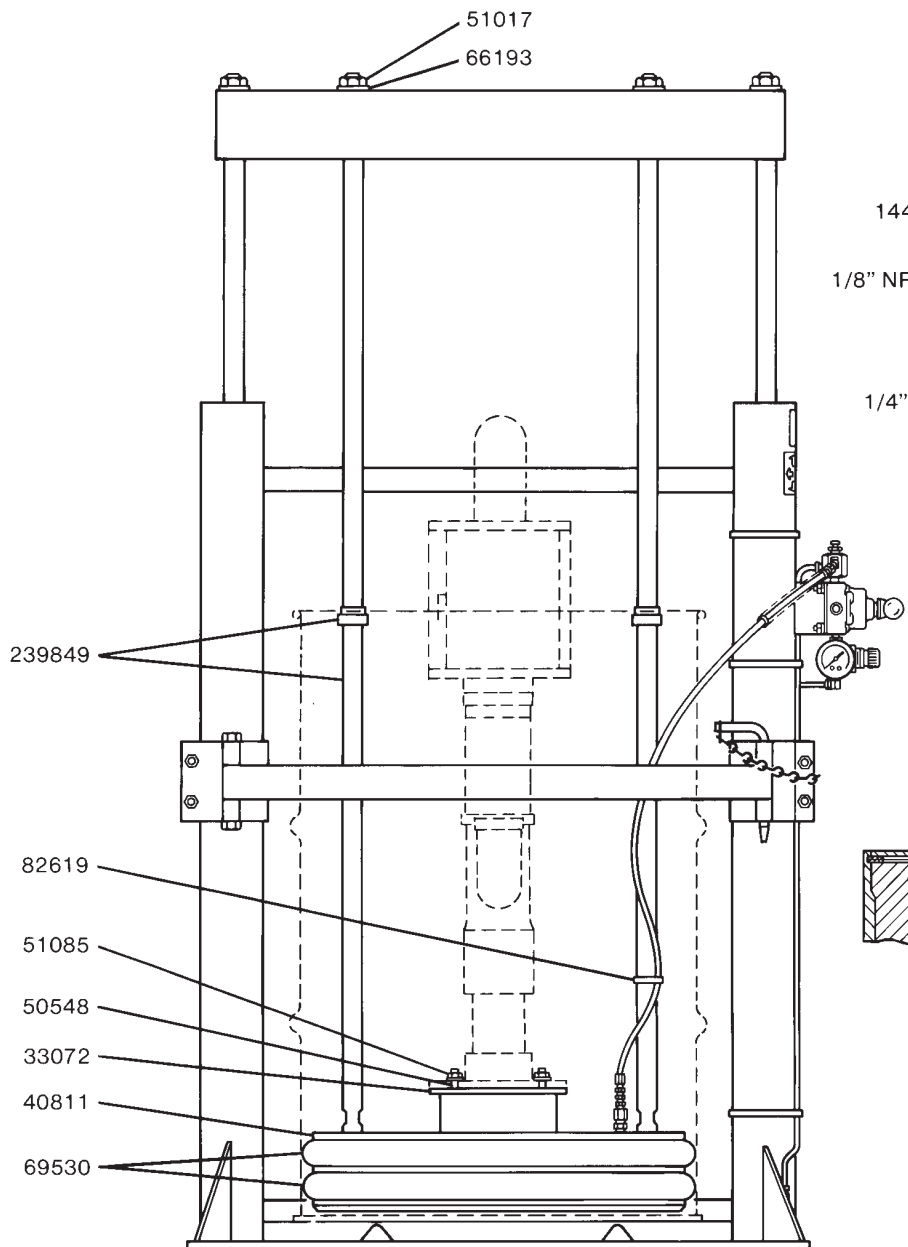
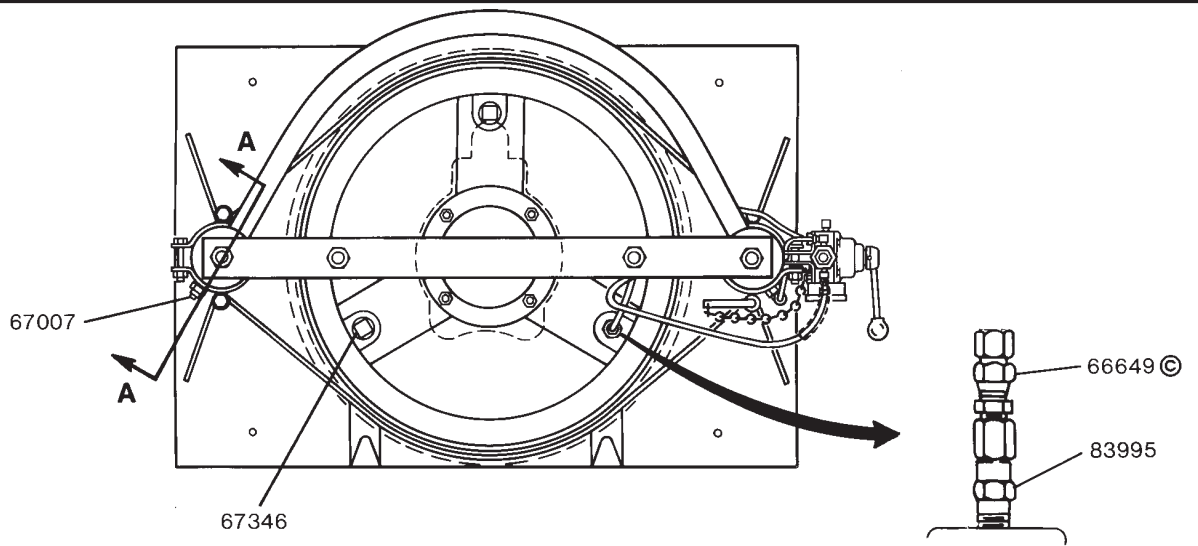

83784 AIR VALVE

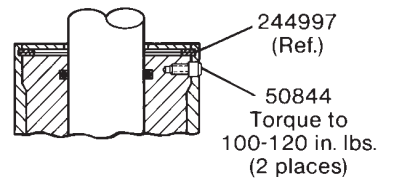

SECTION A - A

© Indicates Change

Model 1735
400 LB. PRESSURE PRIMER FOR PILEDRIIVER PUMPS

OPERATION

To lower the pressure primer into a drum, loosen the probe located in the adapter plate(Power-Master pumps) or in the pump flange (Pile Driver pumps). Then, rotate the four-way valve handle downward to direct compressed air above the twin air pistons, lowering the follower. The rate of descent is limited by the four-way valve's exhaust restrictor. After all air has escaped from beneath the follower, tighten the probe.

Adjust the air regulator supplying air to the pressure primer. Use only enough air pressure to allow the pump to prime. Excessive air pressure will cause the material in the drum to extrude past the follower rings.

To remove the follower from the drum, rotate the four-way valve handle upward. Depress the pushbutton above the four-way valve to provide an air assist under the follower. Without this air assist, a vacuum forms under the follower, retarding upward movement. After vacuum has been overcome, further actuation of the pushbutton is not necessary. The rate of extraction is limited by the four-way valve's exhaust restrictor.

The four-way valve has a positive neutral position which permits stopping the follower in any position. The follower will remain in position even if the airline is disconnected.

SERVICE PARTS

Part	Qty.	Description	Part	Qty.	Description	Part	Qty.	Description
10462	1	Nipple	50844	2	Screw	93075	1	Priming plug
12614	2	Hose stud	51014	7	Nut	93502	1	Valve assembly
12615	2	Coupling nut	51017	4	Nut	93603	1	Support bracket
13266	1	Gland nut	51085	4	Jam nut	93604	1	Channel assembly
14469	1	Valve body	51412	4	Nut	93606	1	Base plate & air cylinder assembly
14923	1	Bushing	55161	1	Spring	237588	1	Four-way air valve
14939	2	Pin	55244	1	Spring	239849	2	Tie rod
20028	1	Angle body	66092	4	Lockwasher	241382	3	Tube connector
33072	1	Follower gasket	66193	4	Lockwasher	241455	2	Collar
34143	1	Packing	66246	2	Lockwasher	241456	2	Piston rod
34337	1	O-ring (Buna-N)	66649	1	Adapter union	241459	2	Collar
34414	2	O-ring (Buna-N)	67007	1	Pipe plug	241461	2	Spring
34478	4	O-ring (Buna-N)	67054	1	Street elbow	241472	3	Cable tie
34568	4	U-cup packing	67346	2	Pipe plug	241679	1	Tube connector
38163	2	U-cup packing	68592	2	Hook	242566	1	Channel
40811	1	Follower	68593	1	Jack chain	242567	2	Piston
50029	1	Screw	69530	2	Follower ring	242569	2	Washer
50051	4	Screw	71900	1	Air hose (4' long)	244996	2	Bushing
50077	4	Screw	82619	1	Strap assembly	244997	2	Retaining ring
50139	2	Screw	83784	1	Air valve	247843	1	Pressure gauge
50141	3	Screw	83995	1	Line check	360615	2	Strap
50142	2	Screw	91629	1	Adapter plate	602003	1	Regulator
50548	4	Screw	92658	2	Clamp	633104	1	Plug

RETAIN THIS INFORMATION FOR FUTURE REFERENCE

When ordering replacement parts, list: Part Number, Description, Model Number and Series Letter.
LINCOLN provides a Distributor Network that stocks equipment and replacement parts.