

# PORTABLE PUMP AND HOIST

5 GALLON CONTAINER

# Model 1725

# Series "C"

## SPECIFICATIONS

Operating air pressure - 50-75 psi

Weight - 90 lbs.

Dimensions - 26-5/8" Wide x 24-5/8" Long x 45-1/2" High

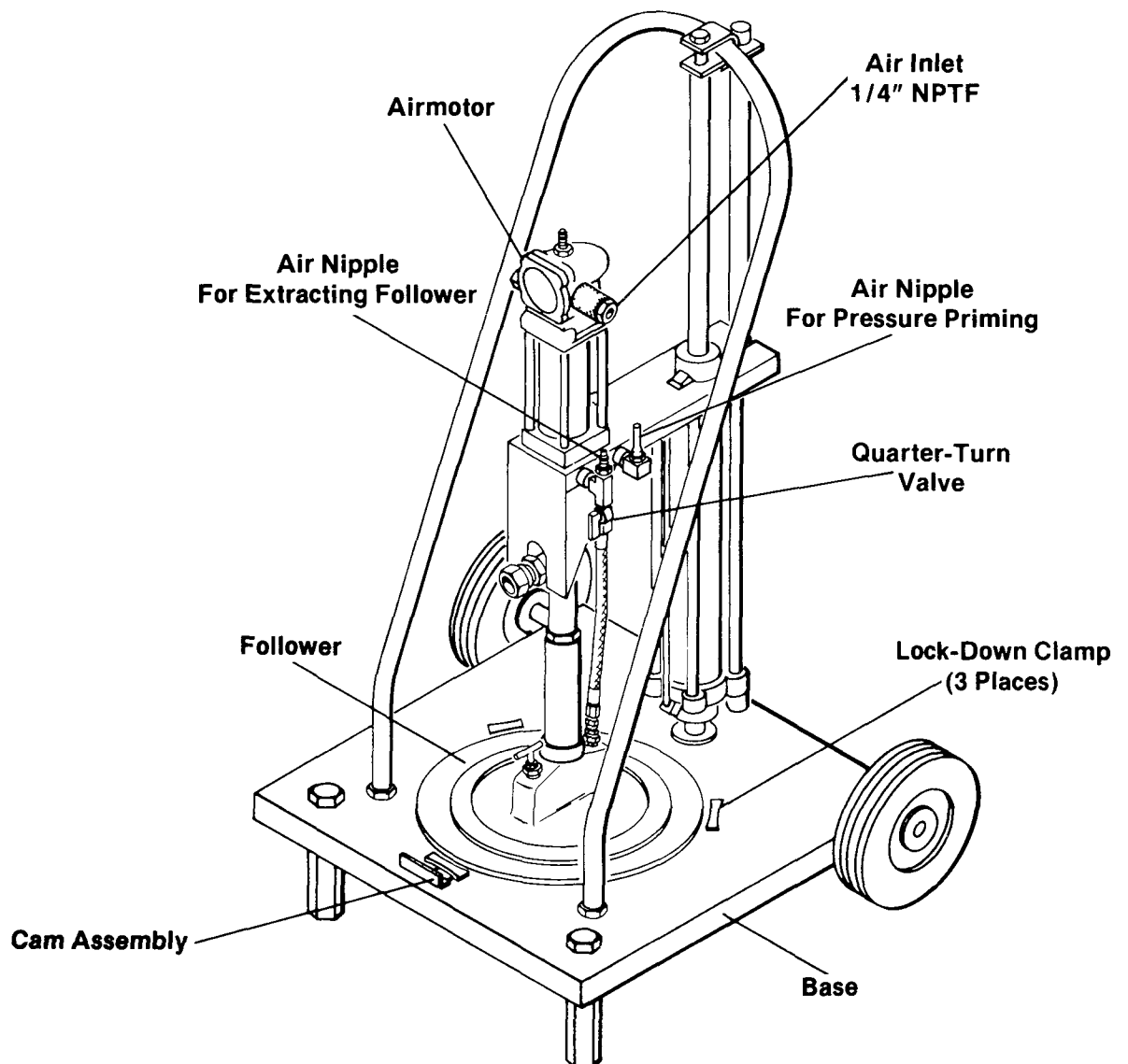

**LINCOLN**  
A PENTAIR COMPANY

One Lincoln Way  
St. Louis, Missouri 63120-1578  
(314) 679-4200

Copyright 1992  
Printed in U.S.A.

Section - A32  
Page - 5C

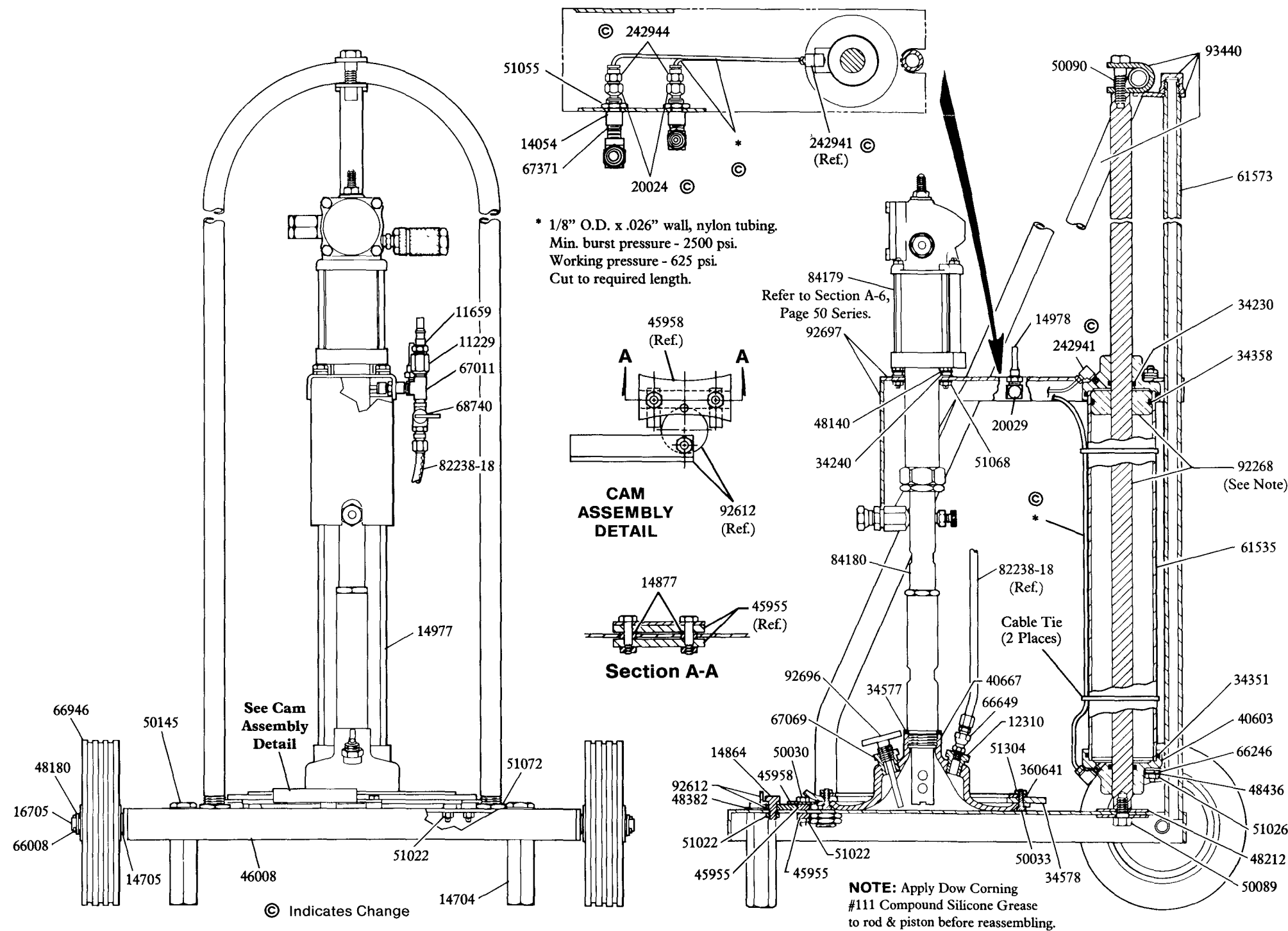

\* 1/8" O.D. x .026" wall, nylon tubing.  
 Min. burst pressure - 2500 psi.  
 Working pressure - 625 psi.  
 Cut to required length.

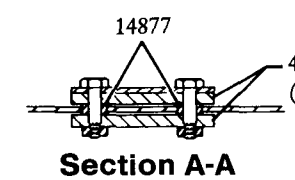
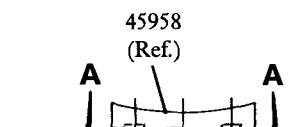

**NOTE:** Apply Dow Corning #111 Compound Silicone Grease to rod & piston before reassembling.

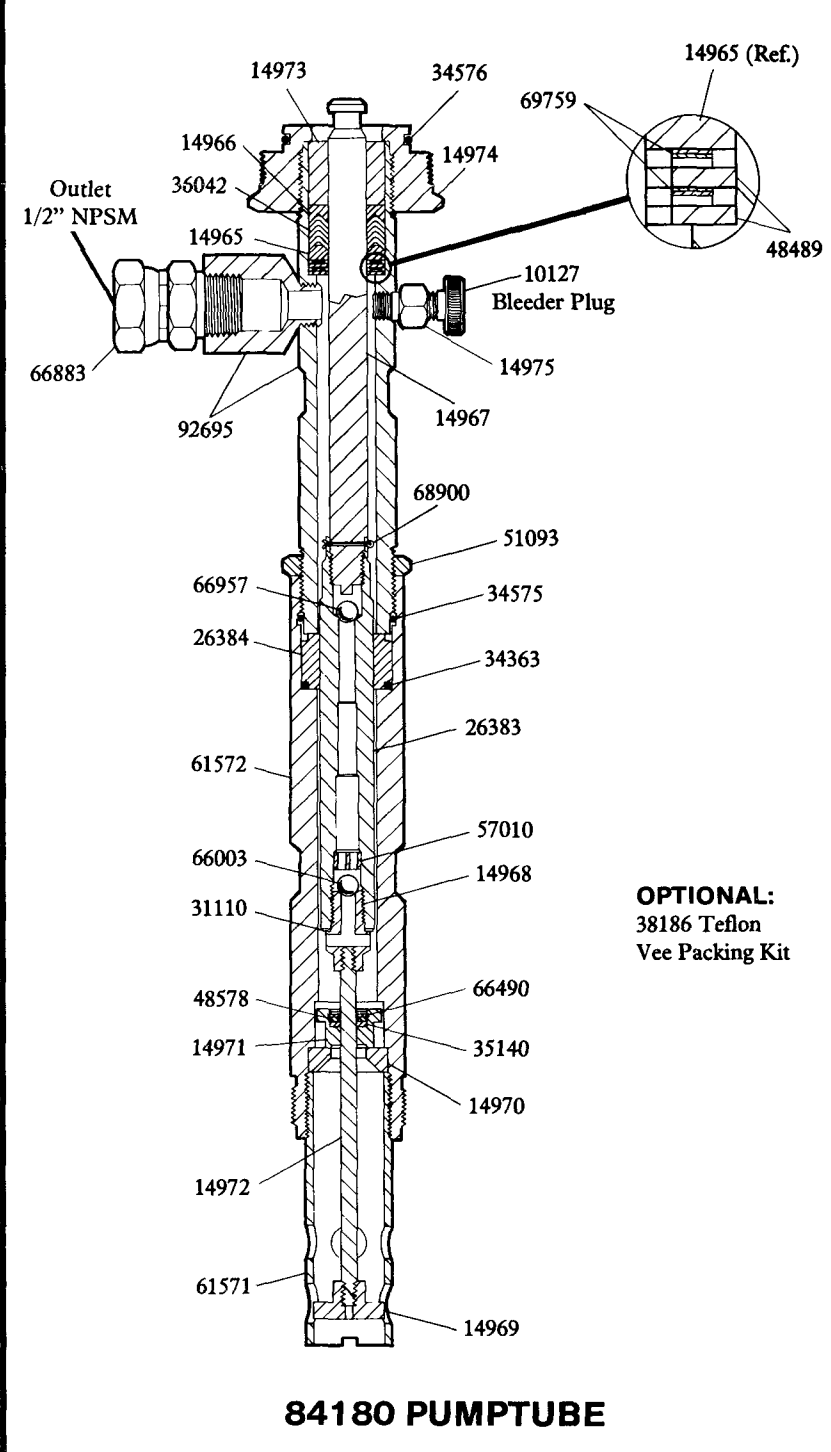

**OPTIONAL:**  
 38186 Teflon  
 Vee Packing Kit

**OPERATION**

- 1) Turn quarter-turn valve to off position (handle horizontal). Attach air coupler to the air nipple adjacent to quarter-turn valve to raise the pump. Place container on the base between the lock-down clamps and turn the cam assembly to clamp container securely in place.
- 2) Remove the vent plug from the follower and the air coupler from the air nipple to lower the follower onto the top of the pail.
- 3) Press air coupler onto the unbarbed air nipple to force the follower against the surface of the material expelling any air beneath the follower through the vent plug opening. Replace the vent plug when material is observed in the opening.

**TO REMOVE EMPTY CONTAINER**

Disconnect the coupler from the air nipple on the airmotor and couple to the air nipple on the support channel. Open the quarter-turn valve (handle vertical) diverting air to both the hoist air cylinder and to the underside of the follower. Shut the quarter-turn valve off once the pump and follower are moving upward. When the follower has cleared the top of the pail, rotate the lock-down cam on the hoist base and remove the pail.

**PRIMING**

Open bleeder plug in pump outlet. Couple air supply line to airmotor. Operate pump until material flows from bleeder plug opening, then tighten bleeder plug and open control valve at the end of the delivery hose. The system is fully primed when material flows from the control valve.

## SERVICE PARTS

Part	Qty.	Description	Part	Qty.	Description
10127	1	Vent plug	48382	2	Washer
11229	1	Bushing	48436	8	Washer
11659	1	Air nipple	48489	2	Washer
12310	1	Bushing	48578	1	Washer
14054	2	Nipple	50030	6	Screw
14704	2	Leg	50033	8	Screw
14705	2	Bushing	50089	1	Screw
14864	1	Cam bolt	50090	1	Screw
14877	2	Spacer	50145	2	Screw
14965	1	Male adapter	51022	7	Nut
14966	1	Female adapter	51026	8	Nut
14967	1	Gland rod	51055	2	Nut
14968	1	Check seat	51068	4	Nut
14969	1	Priming plunger	51072	6	Nut
14970	1	Check seat	51093	1	Nut
14971	1	Bottom check	51304	8	Nut
14972	1	Priming rod	57010	1	Valve tappet
14973	1	Bushing	61535	1	Tube
14974	1	Nut	61571	1	Priming tube
14975	1	Adapter	61572	1	Lower pump tube
14977	4	Tie rod	61573	1	Tube
14978	1	Air nipple	66003	1	1/4" Dia. ball
16705	1	Axle	66008	2	Cotter pin
20024	2	Bushing	66246	8	Lockwasher
20029	1	90° Angle body	66490	1	Retaining ring
26383	1	Pump rod	66649	1	Adapter union
26384	1	Plunger bushing	66883	1	Adapter union
31110	1	Gasket	66946	2	Wheel
34230	2	O-ring (Buna-N)	66957	1	9/32" Dia. ball
34240	4	Packing	67011	1	Tee
34351	2	O-ring (Buna-N)	67069	1	Bushing
34358	1	O-ring (Buna-N)	67371	1	Nipple
34363	1	O-ring (Buna-N)	68740	1	Quarter-turn valve
34575	1	O-ring (Buna-N)	68900	1	Cotter key
34576	1	O-ring (Buna-N)	69759	4	Wave washer
34577	1	O-ring (Buna-N)	82238-18	1	Feeder line hose
34578	1	Follower wiper	84179	1	Divorced airmotor ass'y.
35140	1	Gland packing	84180	1	Pumptube
36042	1	Leather vee packing kit	92268	1	Piston & piston rod ass'y.
40603	2	Cylinder end	92612	1	Cam assembly
40667	1	Follower	92695	1	Outlet pump tube & adapter ass'y.
45955	4	Clamp base	92696	1	Probe assembly
45958	3	Clamp top	92697	1	Support assembly
46008	1	Base	93440	1	Support tube & bracket ass'y.
48140	8	Packing washer	242941	2	Tube connector
48180	2	Swivel washer	242944	2	Tube fitting
48212	2	Washer	360641	1	Wiper ring

**RETAIN THIS INFORMATION FOR FUTURE REFERENCE**

When ordering replacement parts, list: Part Number, Description, Model Number, and Series Letter.

LINCOLN provides a Distributor Network that stocks equipment and replacement parts.

A list of Authorized Service Departments will be furnished upon request.