

**400 LB. DRUM PRIMER  
FOR PILEDRIVER PUMPS**

**USE 84114 MOUNTING KIT  
FOR POWER-MASTER PUMPS**

**SPECIFICATIONS**

**Maximum Air Pressure:** 100 psig

**Priming Pressure**

@ 100 psig: 12 psig

**Raised Height:** 103"

**Lowered Height:** 66"

**Base Dimensions:** 43" x 24"

**DESCRIPTION**

Model 1765 Twin Post Pressure Primer provides priming assistance when dispensing highly viscous materials. The dual follower rings wipe the container wall clean and prevent material from extruding past the follower in the rolled chime areas and in areas with slightly dented surfaces.

Vertical movement is controlled by a manual four-way air valve. Directly above the four-way valve is a pushbutton valve which, when depressed, directs air to the underside of the follower to assist in its withdrawal from the drum. Below the four-way valve is an air regulator to regulate the priming pressure.

**OPERATION**

To lower the pressure primer into a drum, loosen the priming probe located in the pump flange. Then, rotate the four-way valve handle downward to direct compressed air above the twin air pistons, lowering the follower. After all air has escaped from beneath the follower, tighten the probe.

Adjust the air regulator on the pressure primer to set the priming pressure. Use only enough air pressure to allow the pump to prime. Excessive air pressure will cause the material in the drum to extrude past the follower rings. The regulator controls only the priming pressure and does not regulate the pressure to extract the follower.

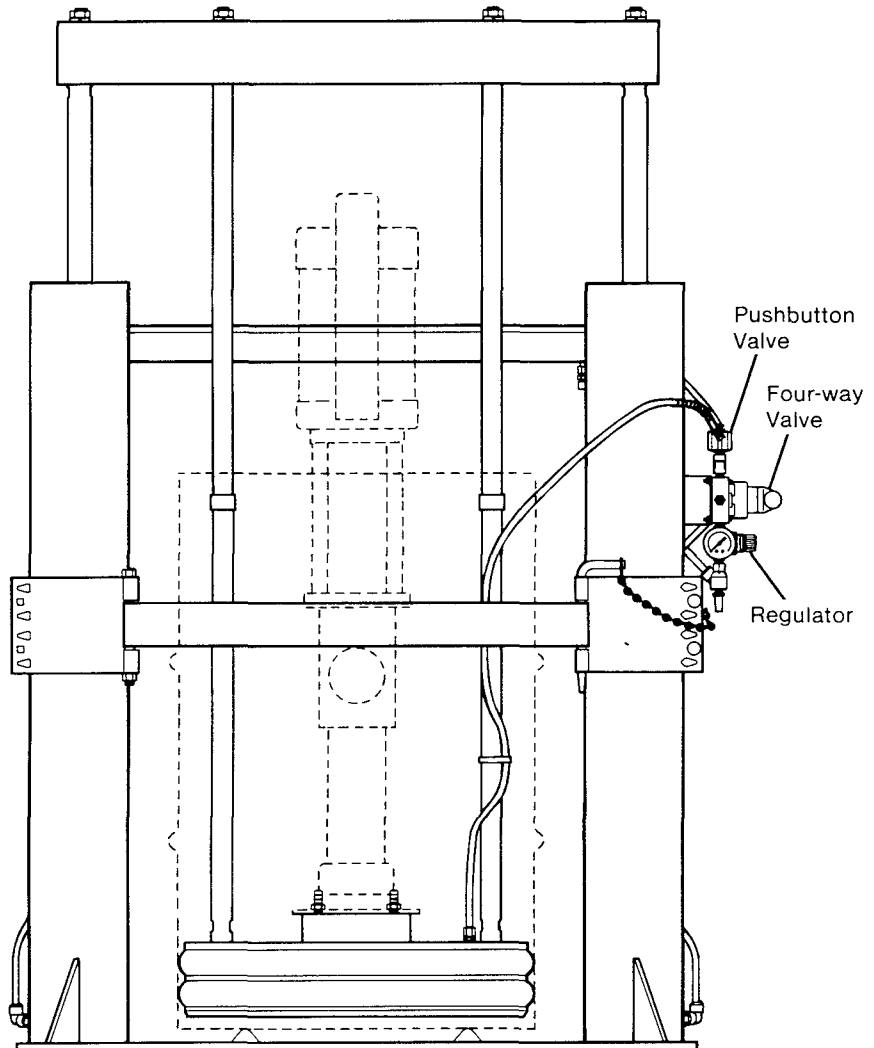

To remove the follower from the drum, rotate the four-way valve handle upward. Depress the pushbutton valve to provide an air assist under the follower. Without this air assist, a vacuum forms under the follower, retarding upward movement. After vacuum has been overcome, further actuation of the pushbutton is not necessary.

The four-way valve has a positive neutral position which permits stopping the follower in any position. The follower will remain in position even if the airline is disconnected.

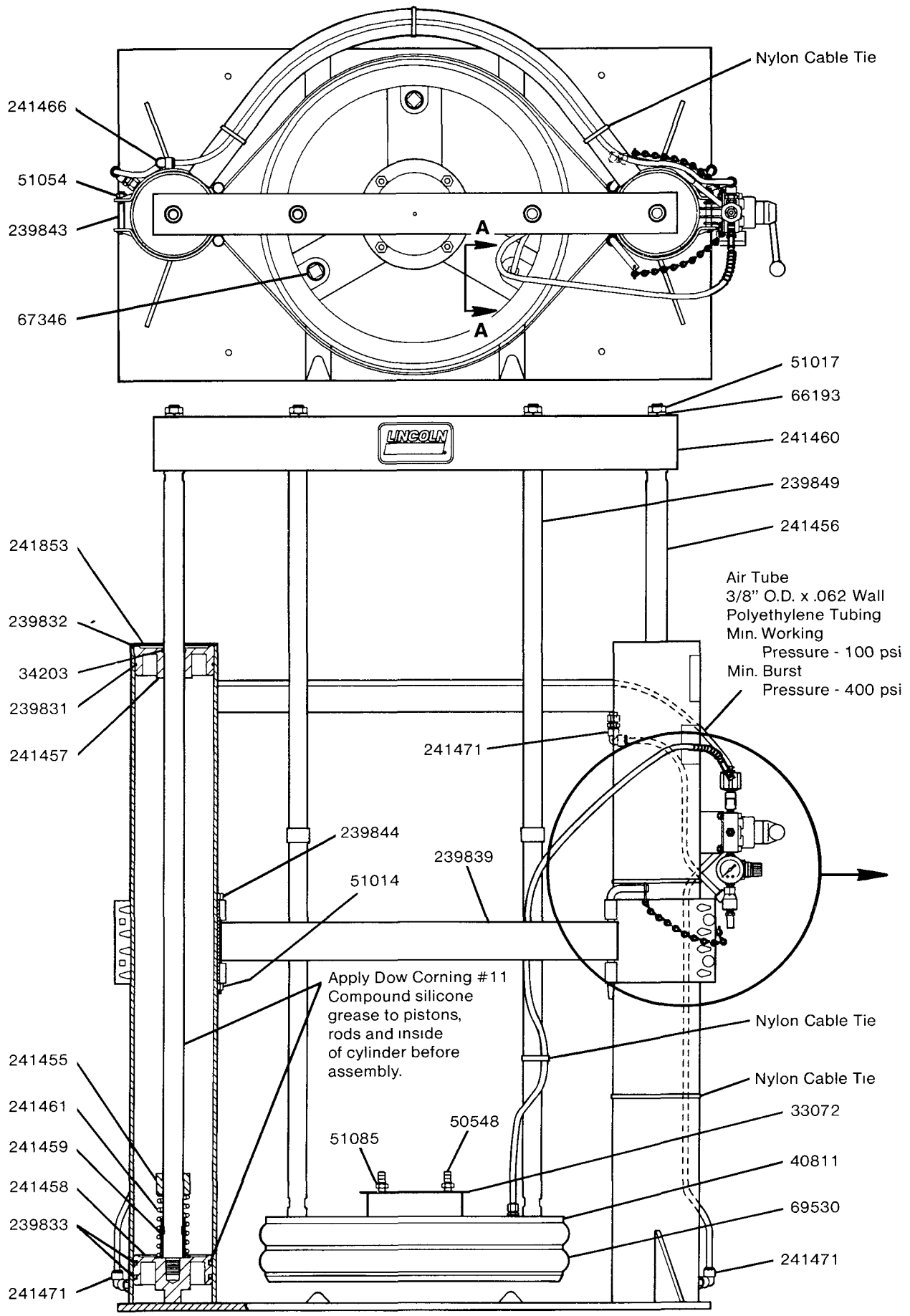

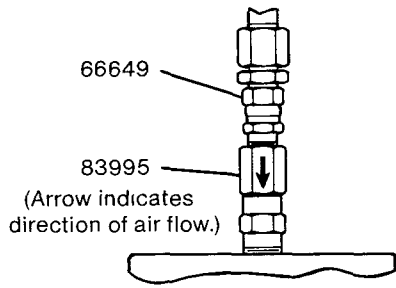

**VIEW A-A**

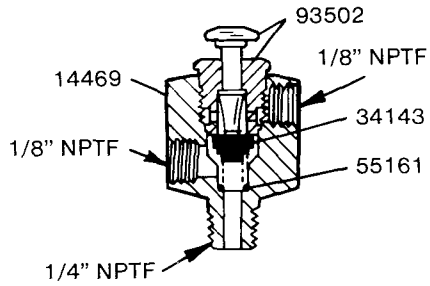

**83784 AIR VALVE**

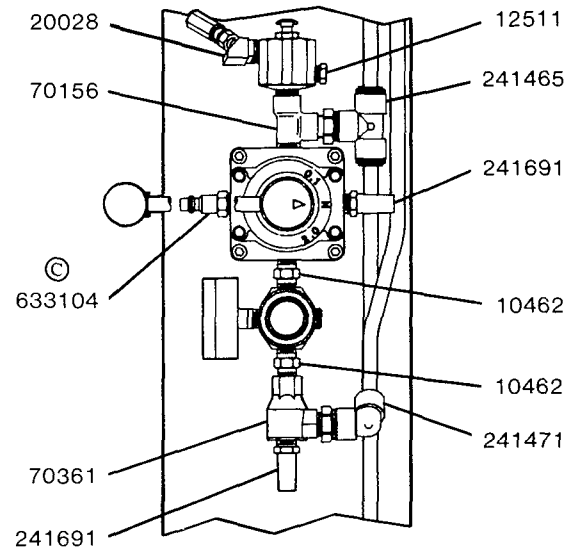
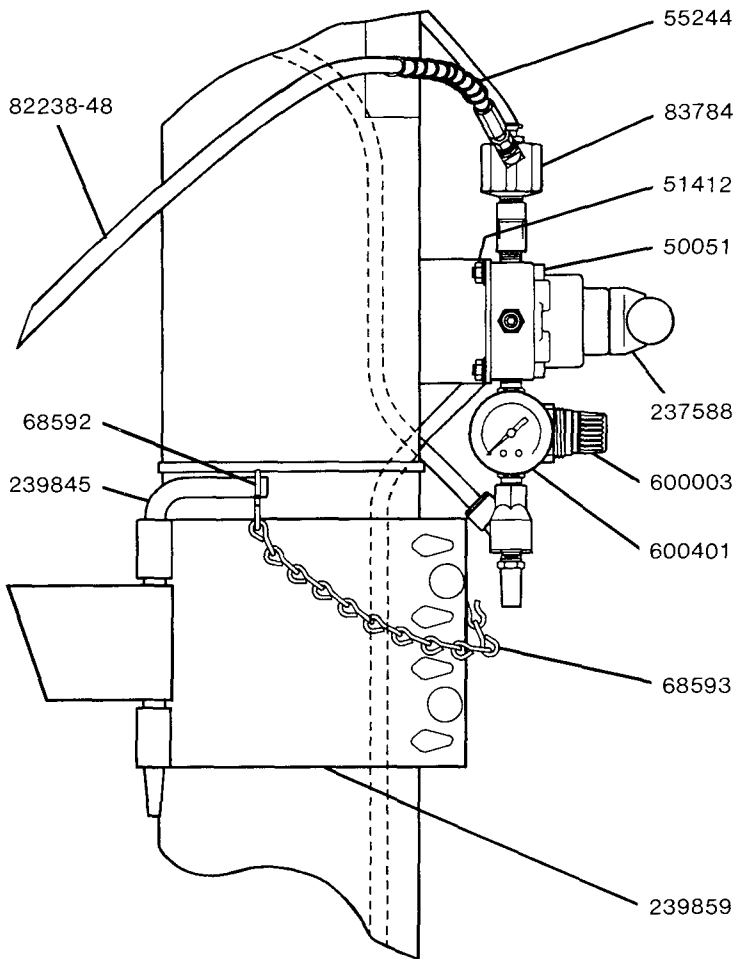
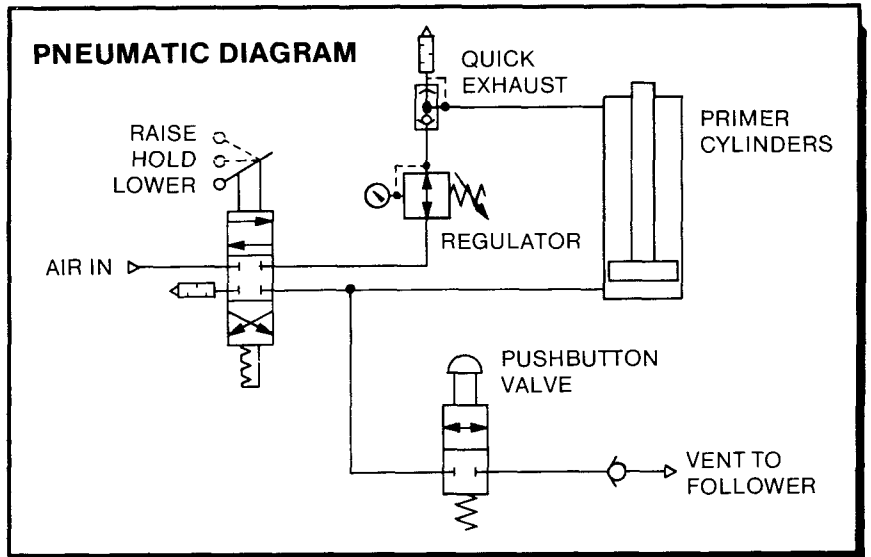

© Indicates Change

## SERVICE PARTS

Part	Qty.	Description	Part	Qty.	Description
10462	2	Nipple	83995	1	Line check
12511	1	Pipe plug	93502	1	Valve assembly
14469	1	Valve body	237588	1	Four-way valve
20028	1	Elbow	239831	2	O-ring (Nitrile)
33072	1	Follower gasket	239832	2	Retaining ring
34143	1	Valve seat (Nitrile)	239833	4	U-cup (Nitrile)
34203	2	O-ring (Nitrile)	239839	2	Strap
40811	1	Follower	239843	4	Round head bolt
50051	4	Screw	239844	2	Screw
50548	4	Set screw	239845	2	Pin
51014	2	Nut	239849	2	Tie rod
51017	4	Jam nut	239859	2	Clamp
51054	4	Nut	241455	2	Spring spacer
51085	4	Jam nut	241456	2	Piston rod
51412	4	Flange nut	241457	2	Bushing
55161	1	Spring	241458	2	Piston
55244	1	Spring	241459	2	Sleeve
66193	4	Lockwasher	241460	1	Crossbeam
66649	1	Adapter union	241461	2	Spring
67346	2	Pipe plug	241465	1	Tube connector
68592	4	Hook	241466	1	Tube connector
68593	2	Jack chain	241471	4	Tube connector
69530	2	Foilower seal (Neoprene)	241691	2	Muffler
70156	1	Street tee	241853	2	Washer
70361	1	Exhaust valve	600003	1	Air regulator
82238-48	1	Hose assembly	600401	1	Pressure gauge
83784	1	Air valve	633104	1	Air nipple

## ACCESSORIES

**84114** Power-Master Pump Mounting Kit

**84141** 3/4" Airline F-R-L Kit

**84144** 1/2" Airline F-R-L Kit

**84143** Low Level Cut-off Kit

### RETAIN THIS INFORMATION FOR FUTURE REFERENCE

When ordering replacement parts, list: Part Number, Description, Model Number and Series Letter.

LINCOLN provides a Distributor Network that stocks equipment and replacement parts.