

PORTABLE CHASSIS LUBRIGUN

Model 3359

120 LB. DRUM SIZE
50:1 RATIO

Series "F"

OVERALL HEIGHT: 42-11/16"
BASE: 18" Sq.

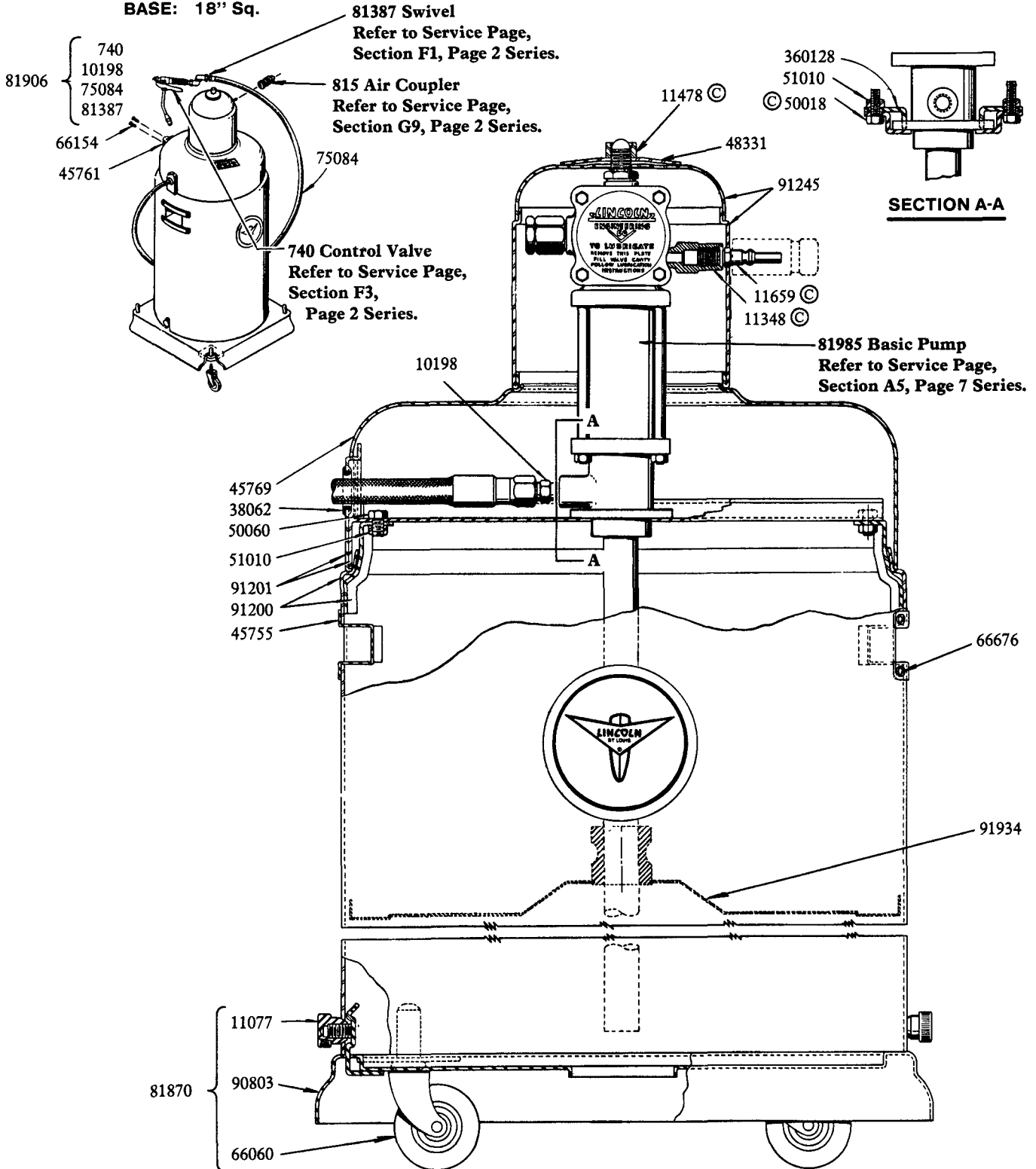

A DIVISION OF
LINCOLN McNEIL
CORPORATION
One Lincoln Way, St. Louis, MO 63120 (314) 679-4200

SECTION - **A5**
PAGE - **40F**

TO CHANGE LUBRICANT DRUMS

- 1) Disconnect air coupler from pump.
- 2) Loosen the two latch knobs on the base several turns.
- 3) Lift sleeve from base, raising it high enough to clear the lubricant drum.
- 4) Fresh drum of lubricant should then be placed centrally on the base.

IMPORTANT: Avoid bumping latch knobs when placing lubricant drum on base.

- 5) Replace the sleeve on the base, being careful to guide the key hole slots onto the latch knobs.
- 6) Tighten latch knobs securely so that sleeve is clamped firmly to the base.

TO REMOVE AIRMOTOR COVER

Remove cover nut & cover cap washer. Tilt the airmotor cover on an angle so that the hole in the cover will clear the air coupler nipple.

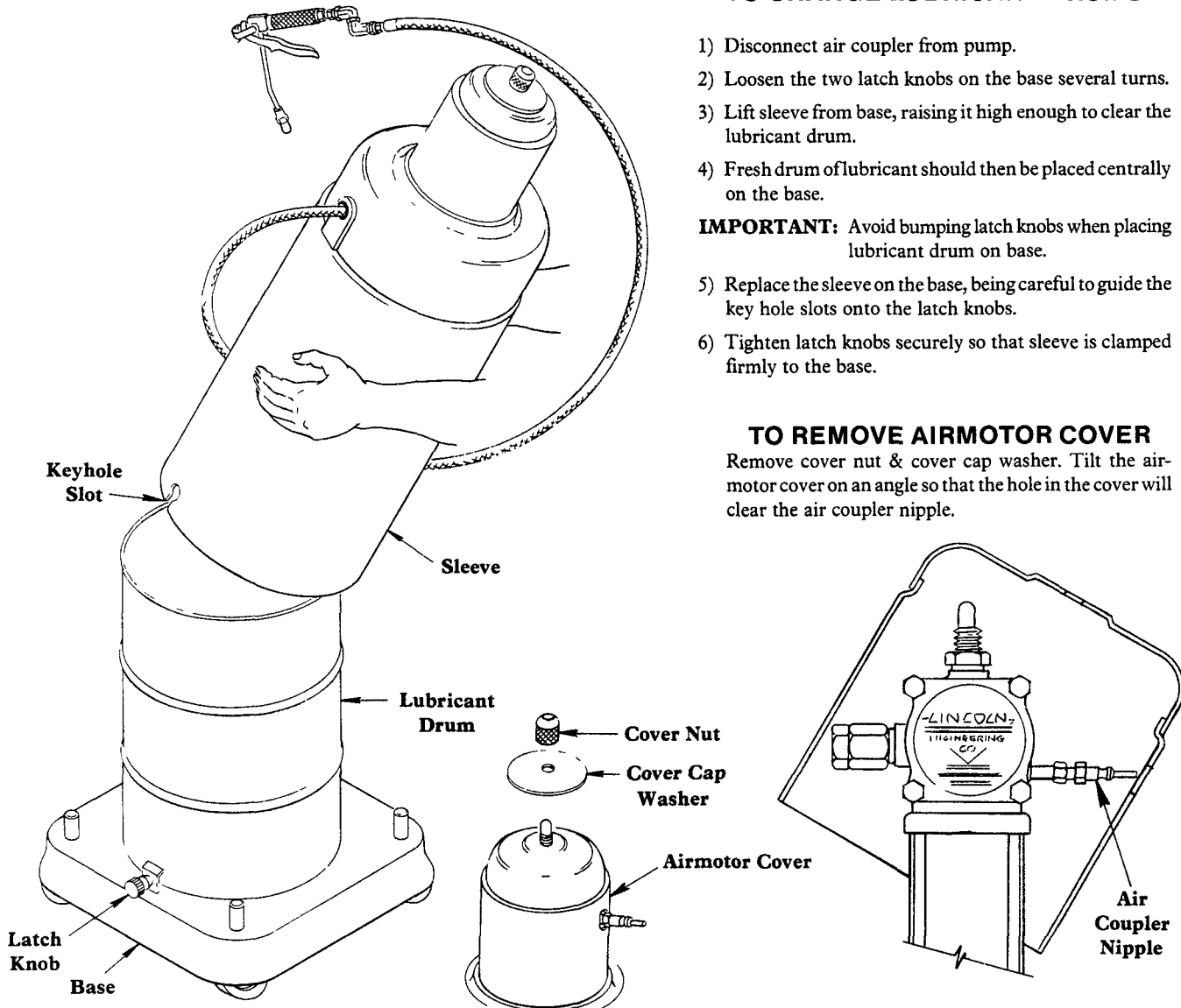

SERVICE PARTS

PART	QUAN.	DESCRIPTION	PART	QUAN.	DESCRIPTION	PART	QUAN.	DESCRIPTION
740	1	Control valve	45769	1	Sleeve cover	81870	1	Truck assembly
815	1	Air coupler	48331	1	Cover cap washer	81906	1	Hose & control valve
10198	1	Hose connector	50018	2	Screw	81985	1	Bare pump
11077	2	Latch knob	50060	2	Screw	90803	1	Base unit
11348	1	Nozzle adapter	51010	4	Nut	91200	1	Sleeve
11478	1	Cover nut	66060	4	Caster	91201	1	Pump support channel
11659	1	Air coupler nipple	66154	2	Screw	91245	1	Airmotor cover
38062	1	Grommet	66676	8	Screw	91934	1	Follower
45755	2	Handle	75084	1	High pressure hose	360128	2	Clamp
45761	1	Control valve hanger	81387	1	Universal swivel			

RETAIN THIS INFORMATION FOR FUTURE REFERENCE

When ordering replacement parts, list: Part Number, Description, Model Number, and Series Letter.

LINCOLN provides a Distributor Network that stocks equipment and replacement parts.

A list of Authorized Service Departments will be furnished upon request.