

OWNER/OPERATOR MANUAL

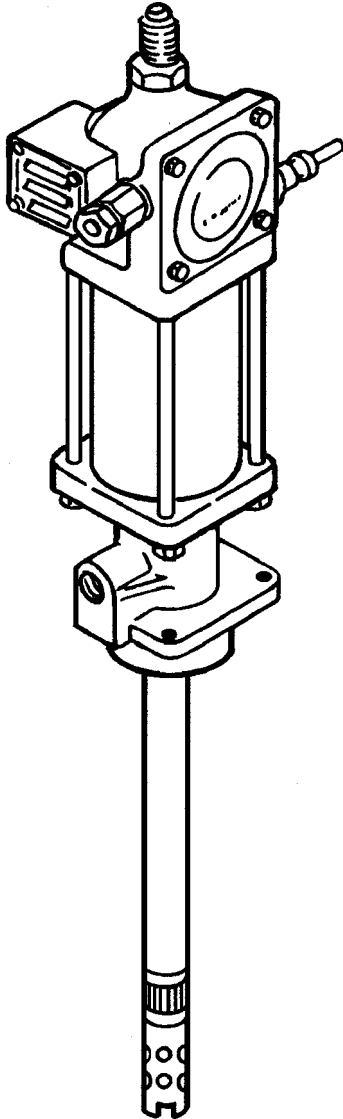

SPECIFICATIONS

Airmotor effective dia. in.	2.5
Air inlet	1/4 NPTF
Material outlet	1/4 NPTF
Ratio	50:1
Delivery output, cubic inches per minute	80
Delivery in cubic inches per cycle	.35 [©]
Minimum air pressure	30 p.s.i.
Maximum air pressure	150 p.s.i.
Max output pressure	7500 p.s.i.
Noise level @120 psig	<85dBA

DESCRIPTION

Model 82716 is an air operated chassis pump designed to pump low and medium viscosity materials (grease) from drums and pails.

OWNER/OPERATOR RESPONSIBILITY

It is the owners/operators responsibility to properly use and maintain this equipment.

The instructions and warnings contained in this manual shall be read and understood by the owner/operator prior to operating this equipment.

If an owner/operator does not understand English, the contents of this manual shall be explained in the owners' operators native language to assure the owner/operator comprehends.

It is the owners/operators responsibility to maintain the legibility of all warning and instruction labels.

The owner/operator shall retain this manual for future reference to important warnings, operating and maintenance instructions.

SAFETY INFORMATION

Read and understand all warnings, cautions and instruction before operating this equipment. Extreme caution should be used when operating this equipment as personal injury and/ or property damage can result from equipment misuse. Adequate personal protection is recommended to prevent splashing of material on the skin or in the eyes. ALWAYS disconnect air coupler from pump when the pump is not being used.

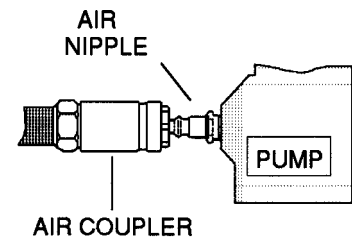

© Indicates change

One Lincoln Way
St. Louis, MO 63120-1578
Phone +1.314.679.4200
Fax +1.800.424.5359

© Copyright 2002
Printed in USA

Web site:
www.lincolnindustrial.com

Section - A5

Page - 54F

WARNING

FAILURE TO HEED THE FOLLOWING WARNINGS INCLUDING MISUSE, OVER PRESSURIZING, MODIFYING PARTS, USING INCOMPATIBLE CHEMICALS AND FLUIDS, OR USING WORN OR DAMAGED PARTS, MAY RESULT IN EQUIPMENT DAMAGE AND/OR SERIOUS PERSONAL INJURY, FIRE, EXPLOSION, OR PROPERTY DAMAGE.

- Do not exceed the stated maximum working pressure of the pump, or of the lowest rated component in your system.
- Do not alter or modify any part of this equipment.
- Do not operate this equipment with combustible gas.
- Do not attempt to repair or disassemble the equipment while the system is pressurized.
- Make sure all grease connections are securely tightened before using this equipment.
- Always read and follow the grease manufacturers recommendations regarding grease compatibility, and the use of protective clothing and equipment.
- Check all equipment regularly and repair or replace worn or damaged parts immediately.
- Never point the dispensing valve at any part of the body or at another person.
- Never try to stop or deflect material from dispensing valve or leading connection or component with your hand or body.
- Always check equipment for proper operation before each use, making sure safety devices are in place and operating properly.
- Always follow the pressure relief procedure after shutting off the pump, when checking or servicing any part of the system, and when installing, cleaning or changing any part of the system.

INSTALLATION

Typical drum and pail hookups are described as follows only as a guide in selecting and installing a system. Contact a Lincoln factory representative for assistance in designing a system for a specific requirement.

WARNING

This pump can develop 7500 PSI working pressure at 150 PSI maximum incoming air pressure. Be sure that all system equipment and accessories are rated to withstand the maximum working pressure of this pump. DO NOT exceed the maximum working pressure of the lowest rated component in the system.

IMPORTANT: Accessory item whip hoses for dispensing valve are rated 4500 PSI. DO NOT exceed 90 PSI air pressure to pump when using whip hoses.

TYPICAL SYSTEM HOOKUP

Determine the drum or pail system for your requirement.

Obtain an air line filter/regulator/lubricator to use with the inlet air supply and the correct sized air and grease lines hoses with any required reducers, connectors and accessories.

Clean/flush the supply lines, hoses, reducers, connectors and accessories with mineral spirits or oil based solvent to purge any contaminants such as dirt, moisture, or metal shavings that could damage the pump or system components. Blow dry with air.

CAUTION

The pump was tested in lightweight oil which was left in to protect the pump from corrosion. Flushing the pump before connecting it to the system might be desired to prevent possible contamination of the grease you are pumping.

WARNING

To reduce the risk of injury from splashing or static sparking when flushing the pump with solvents, always hold a metal part of the dispensing valve firmly to the side of a grounded metal pail and operate pump at lowest possible fluid pressure.

Clean/flush the pump with mineral spirits or oil based solvents if necessary.

Assemble the cleaned pump and supply line together with any required accessory.

Mount the assembled pump to the drum or pail.

Connect the material output line/hose to the pump.

Connect the air regulator to the pump.

Make sure all connections are securely tightened.

ACCESSORIES

Filter/Regulator/Lubricator and Gauge.
Eyebolt Kit.
Follower Plate - 120 lb., 400 lb.
Drum Cover - 120 lb., 400 lb.
Drum Cover with Tie Rods.
1709 Hoist.

PRESSURE RELIEF PROCEDURE

Always perform this procedure when the pump is shut off and before checking, servicing, installing, cleaning or repairing any part of this system.

Perform the following procedure:

- A. Disconnect the air supply to the pump.
- B. Point the dispensing valve away from yourself and others.
- C. Open the dispensing valve into an appropriate container until the pressure is relieved.

If the above procedure does not relieve the pressure, the dispensing valve or hose may be restricted. To relieve the pressure, very slowly loosen the hose end coupling. Then loosen completely and clear the dispensing valve and/or hose.

OPERATION

INSPECTION BEFORE USING PUMP

Prior to operation or maintenance a visual inspection shall be made. Check pump system for leaks, worn or missing parts.

Any pump that appears to be damaged in any way, is badly worn or operates abnormally shall be removed from use until repairs are made. Contact a factory authorized service center for repairs.

If overpressurizing of the equipment is believed to have occurred, contact a factory authorized service center for inspection of the pump.

Annual inspection by a factory authorized service center is recommended.

WARNING

To prevent personal injury, perform PRESSURE RELIEF PROCEDURE before and after operating the pump.

To start pump, turn on the main air supply. Slowly open the air regulator. Regulate air pressure from 20-40 psig and throttle to prime pump. Open the dispensing valve to allow air to be purged from the system. Allow pump to cycle until grease without air pockets flows from dispensing valve, then close dispensing valve.

After pump is primed, adjust air pressure to achieve a smooth flow of grease from the dispensing valve. Do not allow pump to operate when out of material. Pump will accelerate quickly and run too fast, resulting in costly damage to the pump.

If the pump accelerates quickly or is running too fast, stop it immediately. Check the grease supply and refill it if

necessary. Prime the pump to remove all air from the system, or flush the pump and relieve pressure.

In a circulating system, the pump runs continuously and slows down or speeds up as supply demands, until the air supply is shut off.

In a direct supply system, with adequate air pressure supplied to the motor, the pump starts when the gun or dispensing valve is opened and stalls against pressure when it is closed.

Use the air regulator to control pump speed and grease pressure. Always use the lowest pressure required to achieve the desired results. Higher pressures will cause pump packings to wear prematurely.

MAINTENANCE

WARNING

To prevent personal injury, perform PRESSURE RELIEF PROCEDURE before and after operating the pump and before any maintenance.

LUBRICATION

An air line filter/regulator/lubricator is recommended for use with your Lincoln pump to remove harmful dirt and moisture from your compressor air supply, and to provide automatic air motor lubrication.

If an air line lubricator is not used, the following procedure should be performed daily:

- A. Disconnect air coupler from air fitting.
- B. Fill air coupler with NO. 10 SAE motor oil and reconnect to air fitting.
- C. Operate pump to distribute lubricant.

MATERIAL RESTRICTION PREVENTION

Flush the system as required with a compatible solvent to prevent material buildup when pumping material that dries or hardens.

CORROSION PREVENTION

WARNING

To reduce the risk of injury from splashing or static sparking when flushing the pump with solvents, always hold a metal part of the dispensing valve firmly to the side of a grounded metal pail and operate pump at lowest possible fluid pressure.

To prevent water or air corrosion, never leave the pump filled with water or air. Flush the pump first with a compatible solvent and then again with mineral spirits or oil based solvent.

DISASSEMBLY

WARNING

To prevent personal injury, perform PRESSURE RELIEF PROCEDURE before and after operating the pump and before performing any disassembly or assembly.

NOTE

If complete disassembly is required, order the repair kit and replace ALL gaskets, O-rings and packings.

- A. Remove valve cap (11470) and trip rod pin (11472).
- B. Unscrew four nuts (51009) from tie rods (10294) and remove trip rod collar (11471).
- C. Unscrew trip sleeve (11947) from trip rod (90691) and lift air valve casting (237563©) off of air cylinder (61041).
- D. Remove packing nut (11904) and packing cap (11905) from air valve casting.
- E. Remove four valve cover screws (236868) and cover (236286).
- F. Remove four toggle plate screws (236869), toggle assembly (91331) and trip shoe (11475).
- G. Remove four valve seat screws (236870), springs (55138), valve guide plate (45605) and valve slide seat and gasket (83063).
- H. Unscrew trip rod packing nut (245425) from air valve casting and remove all packing parts.
- I. Unscrew pump tube from outlet body (40537).
- J. Remove air cylinder (61041) and air passage tube (61502) from outlet body.
- K. Extend air motor piston rod (11340) out bottom of outlet body. Place wrenches on air piston bolt (11329) and on wrench flats of piston rod and unscrew piston rod. Thread piston rod through gland packing to allow removal of pump tube.

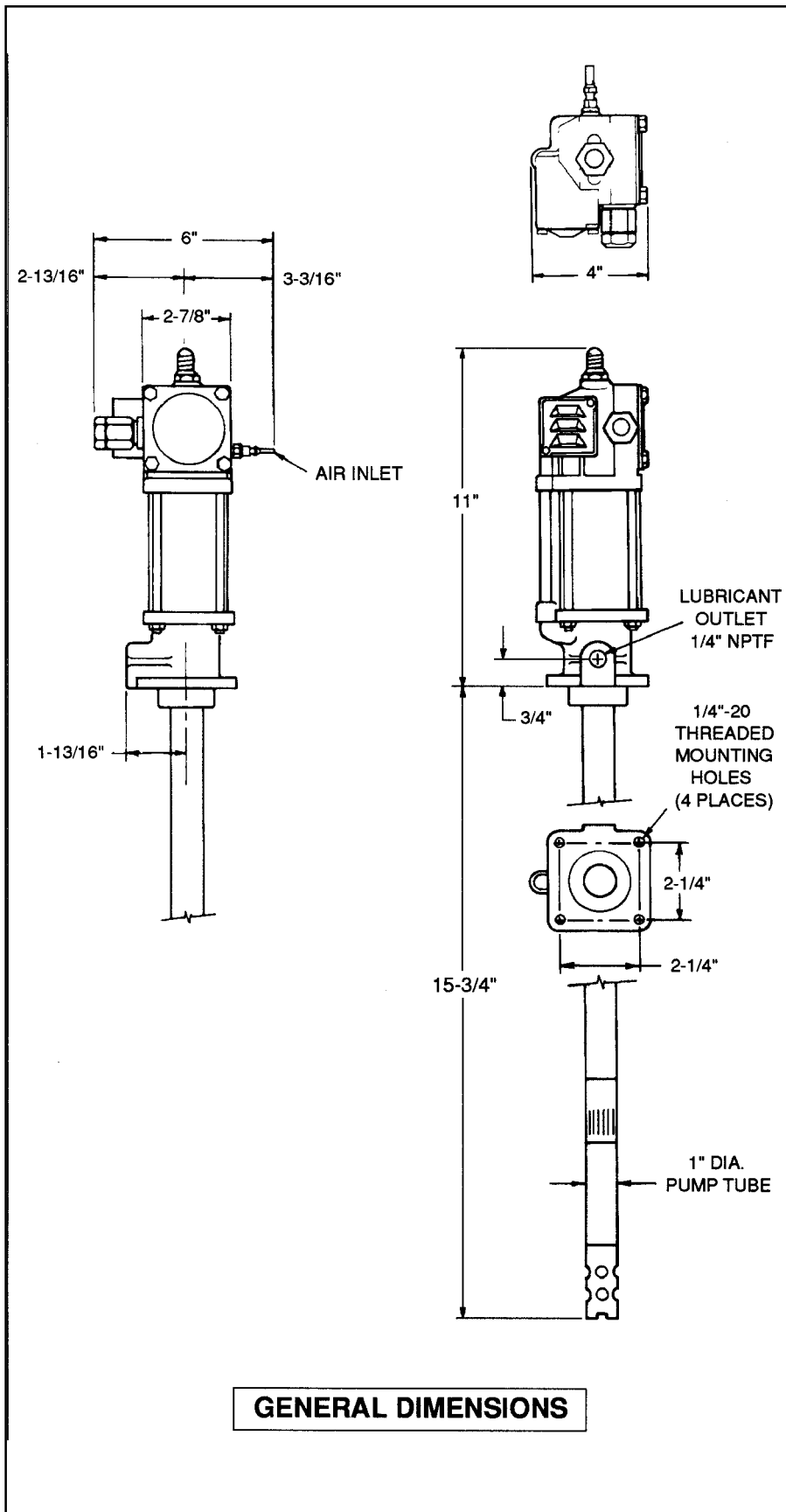

© Indicates change

- L. Unscrew gland packing nut (12333) from outlet body and remove all gland parts.
- M. Remove priming tube (61275) from bushing extension(61273).
- N. Extend plunger rod (11723) out bushing extension and unscrew priming plunger (11724) to allow removal of priming check parts and plunger rod (11723).
- O. Remove bushing extension (61273) and unscrew plunger and bushing assembly (90554) from pump tube. Unscrew coupling nut (12211) from coupling adapter (12210) to allow removal of plunger and bushing assembly intact, reducing the chance of losing ball stop (57027) and check ball (69102©).

ASSEMBLY

To assemble, perform DISASSEMBLY procedures in reverse. Tighten fasteners per stated torque specifications.

IMPORTANT: To prevent damage to air piston packing and pump gland packing, and to help increase packing life, lubricate air cylinder and air piston rod before assembly. Thread piston rod through gland packing when assembling pump.

Before tightening four valve seat screws (236870), align valve slide and seat plate (83063), slide valve gasket (38162) and air valve casting (237563©) by placing a rod through the center hole.

Start all fasteners by hand to avoid stripping threads when reassembling.

REPAIR

Repair is limited to replacement of listed service parts. Special procedures and tools are required. Contact Lincoln Customer Service, One Lincoln Way, St. Louis, MO 63120-1578, (314) 679-4200 for your nearest authorized service center.

When ordering replacement parts, list: part number, description, model number and series letter.

SERVICE PARTS

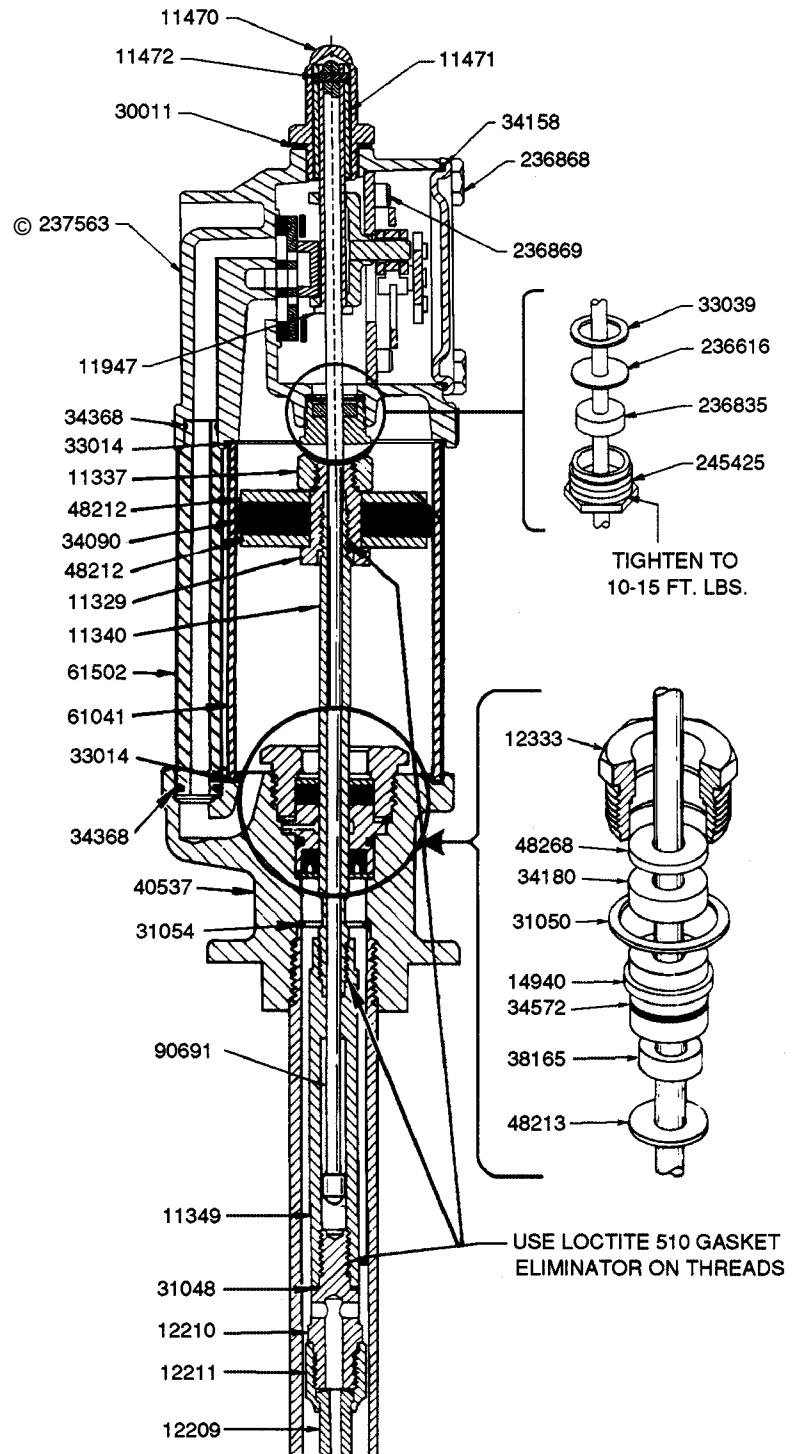

© Indicates change

TROUBLESHOOTING

If the following procedures do not correct the problem, contact a factory authorized service center. When submitting equipment to be repaired, be sure to state the nature of the problem and indicate if a repair cost estimate is required.

PROBLEMS

AIRMOTOR DOES NOT OPERATE.

- Check air supply to pump.
- Check for broken trip rod.
- Broken toggle or foreign object lodged in priming tube. Check for rust, worn or scored parts.

AIR SEEPAGE FROM AIR EXHAUST WHILE PUMP IS NOT OPERATING

- Check valve slide (83063), seat and gasket. Check trip rod packing (236835) and gasket (33039) for cut or damaged packing.

LOSS OF PRESSURE, VOLUME OR CONTINUOUS OPERATION OF PUMP WHEN NOT IN NORMAL USE.

- Remove and clean lower inlet checks. Check for foreign material.
- Inspect sealing surfaces between upper and lower inlet checks. Replace if rough or pitted.
- Replace shovel rod if rough or pitted. Replace shovel rod packing (35073).
- Inspect lubricant supply line for leaks or breaks.

LUBRICANT LEAKING FROM WEEP HOLE IN OUTLET CASTING.

Replace O-ring (34572) and U-cup (38165). Make sure gland nut (12333) is tight.

EXCESSIVE AMOUNT OF AIR IN LUBRICANT OR EXCESSIVE AMOUNT OF LUBRICANT COMING FROM AIR EXHAUST.

NOTE

Some lubricant exhausts with air normally.

- Replace gland packing (34180), gland gasket (31050), O-ring (34572) and-U-cup packing (38165).

SERVICE PARTS (CONT)

NOMEN.	PART NO.	WEIGHT	LENGTH
BASIC PUMP	82716	-	-
PUMP TUBE	61321	-	8-51/64"
DRUM SIZE	-	30 LB.	-

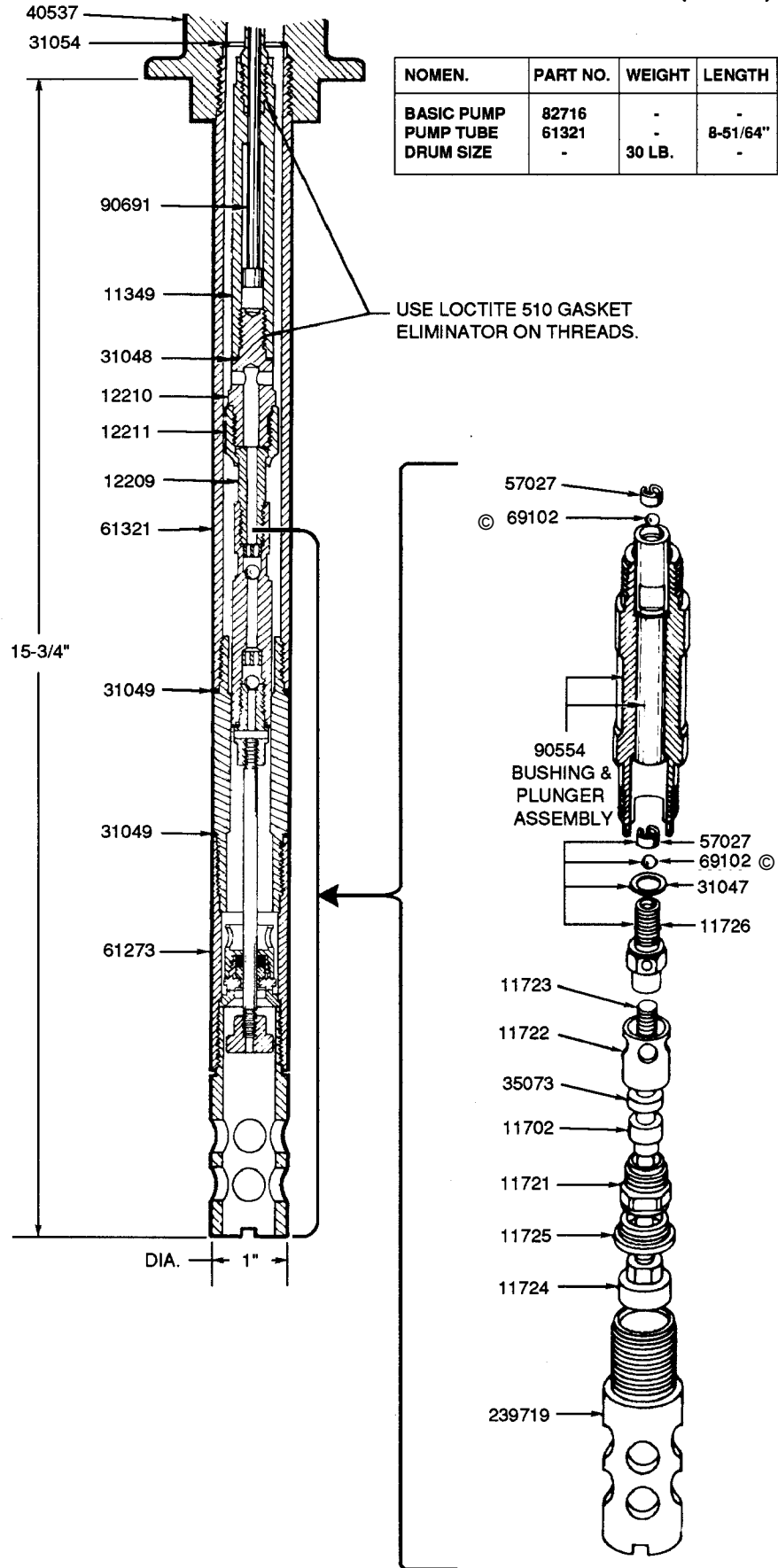

SERVICE PARTS (CONT)

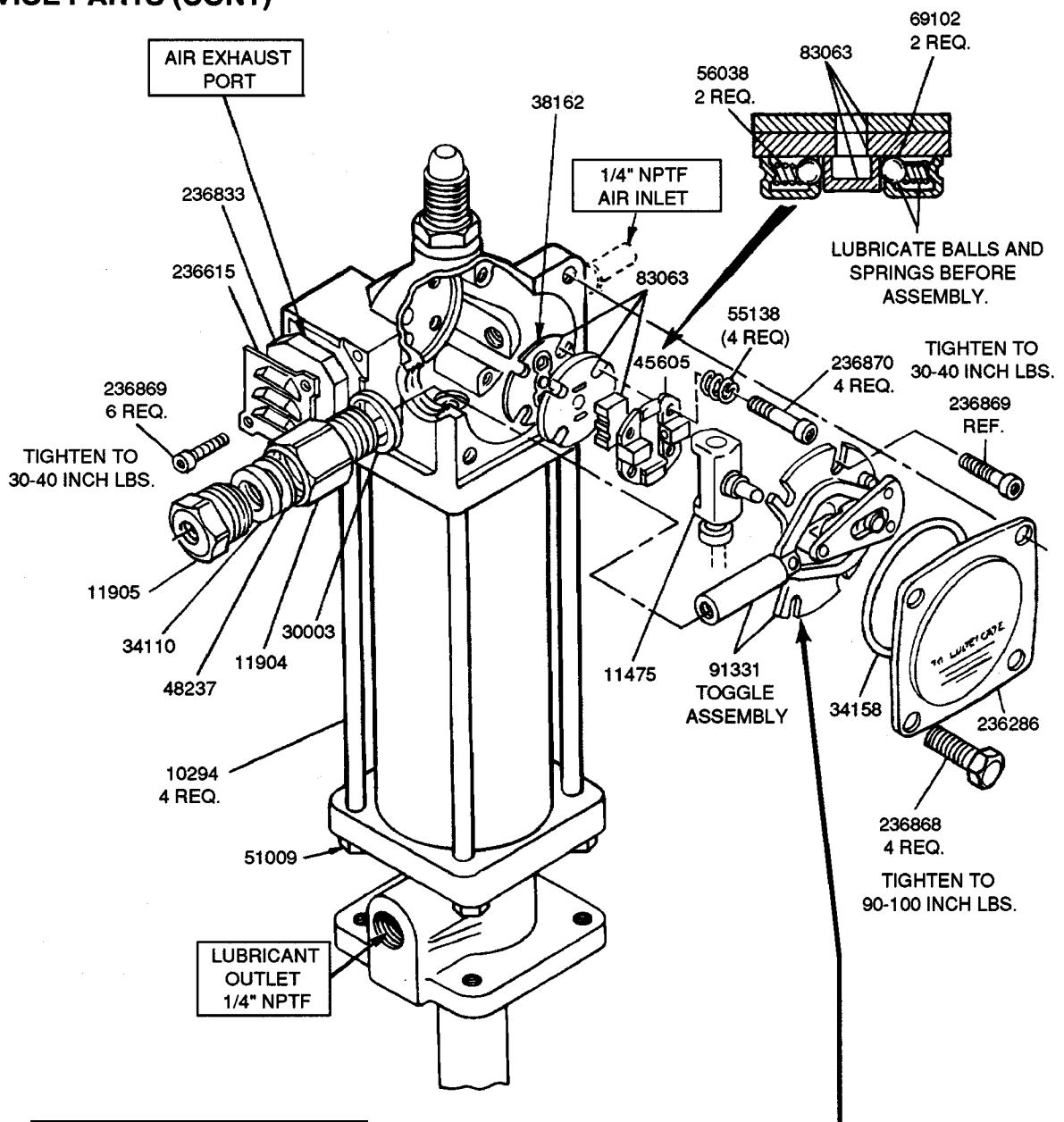

IMPORTANT

Start fasteners by hand to avoid stripping threads when reassembling.

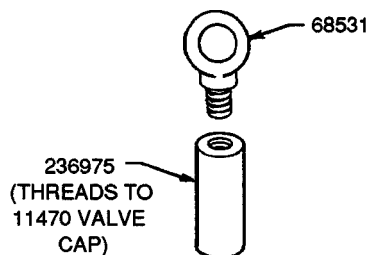

OPTIONAL EYEBOLT KIT
(FOR HOISTING PURPOSES. PARTS MUST BE ORDERED SEPARATELY.)

TO LUBRICATE AIR VALVE MECHANISM

- A. Disconnect air to pump.
- B. Perform pressure relief procedure.
- C. Remove four cover screws, cover plate and cover plate gasket.
- D. Remove air valve casting from the pump and disassemble.
- E. Clean or flush the air valve casting to remove any chips or other foreign particles.
- D. Before replacing toggle assembly, pack cavity with grease using approximately 1-1/2 ounces of N.L.G.I. No. 1 (light grade) water repellent grease.
- F. Replace cover plate gasket, cover plate and cover screws. Tighten to prevent air leaks.
- G. Periodic inspection of parts at least once a year is advised.

Part	Qty	Description	Part	Qty	Description	Part	Qty	Description
10294	4	Tie rod	30003%	1	Packing nut gasket	55138	4	Spring
11329	1	Air piston bolt	30011%	1	Valve cap gasket	56038%	2	Spring
11337	1	Air piston nut	31047%*	1	Check seat gasket	57027	2	Ball stop
11340%	1	Air motor piston rod	31048%	1	Connector gasket	61041*	1	Air cylinder
11349	1	Piston rod connector	31049	2	Bushing gasket	61273	1	Bushing extension
11470	1	Valve cap	31050%	1	Gland gasket	61321	1	Pump tube
11471	1	Trip rod collar	31054%	1	Pump tube gasket	61502	1	Air passage tube
11472%	1	Trip rod pin	33014%	2	Air cylinder gasket	68531	1	Eye bolt
11475#	1	Trip shoe	33039%	1	Gasket	69102%*	4	Ball ©
11702%*	1	Check washer	34090#	1	Air piston packing	83063	1	Valve slide & seat
11721%*	1	Priming check	34110%	1	Plunger packing	90544	1	Plunger & bushing assy
11722	1	Check stop	34158%	1	Cover gasket	90691#	1	Trip rod
11723%*	1	Plunger rod	34180%	1	Gland packing	91331#	1	Toggle plate
11724%*	1	Priming plunger	34368%	2	O-ring	236286	1	Cover
11725%*	1	Priming check seat	34572%	1	O-ring	236615	1	Muffler cover
11726%*	1	Check seat	35073%*	1	Priming check packing	236616%#	1	Packing washer
11904	1	Packing nut	38162%	1	Slide valve gasket	236833	1	Muffler
11905	1	Packing cap	38165%	1	U-cup packing	236835%#	4	Trip rod packing
11947	1	Trip sleeve	40537	1	Outlet body	236868	6	Valve cover screw
12209	1	Coupling stud	45605	1	Valve guide plate	236869	4	Toggle plate screw
12210	1	Coupling adapter	48212	2	Air piston washer	236870	1	Valve seat bolt
12211	1	Coupling nut	48213	1	Gland pack'g washer	236975	1	Extension adapter
12333	1	Gland packing nut	48237	1	Plunger pack'g washer	237563	1	Air valve casting ©
14940	1	Gland packing spacer	48268	1	Gland packing washer	239719	1	Priming tube
			51009	4	Tie rod nut	245425	1	Trip rod packing nut

% Included in 83054 Pump Repair Kit.

* Included in 83001 Power Pump Tube Repair Kit.

Recommended Service Part

© Indicates change

LIMITED WARRANTY

Lincoln warrants that lubrication equipment, materials dispensing equipment and other related equipment manufactured by it will be free from defects in material and workmanship during the one (1) year following the date of purchase. If equipment proves to be defective during this warranty period, it will be repaired or replaced without charge, provided that factory examination indicates the equipment to be defective. To obtain repair or replacement, it must be shipped, transportation charges prepaid, with proof of date of purchase to a Lincoln authorized Warranty and Service Center within the one (1) year following the date of purchase.

This warranty is extended to the original retail purchaser only. This warranty does not apply to equipment damaged from accident, overload, abuse, misuse, negligence, faulty installation or abrasive or corrosive materials, or to equipment repaired or altered by anyone not authorized by Lincoln to repair or alter the equipment. This warranty applies only to equipment installed and operated according to the recommendations of Lincoln or its authorized field personnel. No other express warranty applies to lubrication equipment, materials dispensing equipment, and other related equipment manufactured by Lincoln.

ANY IMPLIED WARRANTIES applicable to lubrication equipment, materials dispensing equipment, and other related equipment manufactured by Lincoln INCLUDING THE WARRANTIES OF MERCHANTABILITY AND FITNESS FOR A PARTICULAR PURPOSE, WILL LAST ONLY FOR ONE (1) YEAR FROM THE DATE OF PURCHASE. SOME STATES DO NOT ALLOW LIMITATIONS ON HOW LONG AN IMPLIED WARRANTY LASTS, SO THE ABOVE LIMITATION MAY NOT APPLY TO YOU.

In no event shall Lincoln be liable for incidental or consequential damages. The liability of Lincoln on any claim for loss or damage arising out of the sale, resale, or use of lubrication equipment, materials dispensing equipment, and other related equipment shall in no event exceed the purchase price. SOME STATES DO NOT ALLOW THE EXCLUSION OR LIMITATION OF INCIDENTAL OR CONSEQUENTIAL DAMAGES, SO THE ABOVE LIMITATION OR EXCLUSION MAY NOT APPLY TO YOU.

THIS WARRANTY GIVES YOU SPECIFIC LEGAL RIGHTS AND YOU MAY ALSO HAVE OTHER RIGHTS WHICH VARY FROM STATE TO STATE.