

FOR MODELS 81685, 81941, 81985, 82050, 82054, 82716,
83121, 83127, 83513 - (2-1/2" AIR MOTOR - 50:1 RATIO)

NOTE: © INDICATES CHANGE. SEE PARTS LIST FOR REPLACEMENT / NEW PART NUMBERS.
PART NUMBERS MARKED WITH AN ASTERISK (*) ARE INCLUDED IN REPAIR KIT.

OLD STYLE

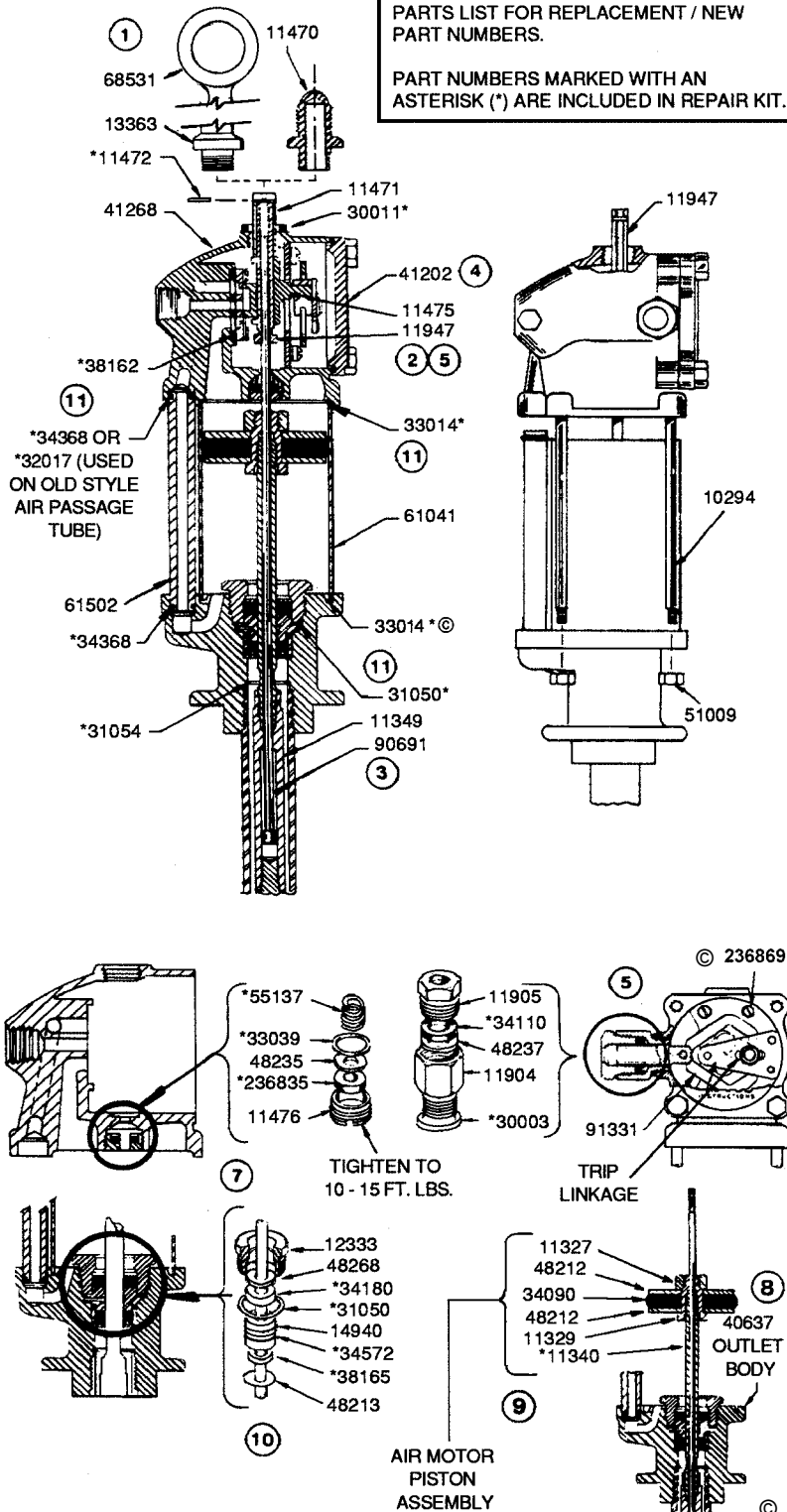

- Unscrew 11470 or 13363 with 68531. Drive pin (11472) from collar (11471). Collar is free to be removed.
- Turn trip sleeve (11947) counterclockwise by hand to unscrew from trip rod (90691). Note: Trip rod (90691) cannot be removed until pump tube is disassembled.
- Unscrew four nuts (51009) from tie rods (10294). Lift entire airmotor straight up until free of trip rod (90691). Refer to Step 9.
- Unscrew four screws (50016) and remove cover plate (41202). Replace the cover gasket (34158).
- Remove cap (11905) and replace the packing (34110). Coat the inside surface of the nut (11904) and the outside surface of the packing (34110) with lubricant before assembly. Replace packing nut gasket (30003). Remove four toggle plate screws (236869).

Lift out toggle plate assembly (91331) to inspect. If pins or plates are loose, or if holes in trip linkage are worn out of round and appear egg-shaped, replace toggle plate assembly. Trip shoe (11475) and trip rod sleeve (11947) are free after toggle plate assembly is removed.
- Remove the four valve seat bolts (11906) and the springs (55138). Remove guide plate (45605), replace the two equalizer balls (66010) and the two springs (56038). Remove valve slide and seat and inspect for wear by sliding the valve block from side to side on the valve plate. If wear is apparent, replace with valve slide, seat and gasket (83063).
- Remove trip rod packing nut (11476) (use a wide blade screw driver). Packing (236835) and washer (48235) are housed in recess of nut. Grease inside of nut (11476) and fill spring housing and air motor casting before replacing and installing packing (236835) and spring (55137).
- Place outlet body (40537) in a horizontal position in vise. Remove pump tube from outlet body of air motor. Refer to Steps 12 through 16.

© indicates change

One Lincoln Way
St. Louis, MO 63120-1578
Customer Service (314) 679-4200

Copyright 2001
Printed in U.S.A.

Section - **A5**
Page - **63B**

OLD STYLE (CONT.)

- After pump tube has been completely taken apart the piston (34090) and two piston washers (48212) can be removed by unscrewing the piston bolt (11329) from the piston rod (11340).

To remove rod (11340) use a threading motion to unscrew from packings in outlet body (40537). Use wrench on milled flats of rod (11340). Use same procedure when installing rod (11340) in new packings to prevent the threads on rod from damaging packings.

- Unscrew gland nut (12333). Remove and replace packing (34180). Remove gland packing spacer (14940). Remove and replace O-ring (34572) and U-cup (38165) from gland packing spacer (14940).

When reassembling piston rod (11340) through packings in outlet body (40537), do not force rod through packings as the threaded position portion of the rod will damage packings. Insert piston rod and use a threading motion to move the rod (11340) through the packings.

- The two air cylinder gaskets (33014) and two air passage tube O-rings (34368) are to be replaced as the air motor is reassembled.

- See Fig. A. Lay pump horizontal in vise and grip outlet body lightly in vise jaws. Hold extension tube (61273) and unscrew priming tube (239719).

- See Fig. B. Pull plunger (11724) straight out until plunger rod (11723) is extended as far as possible out of the extension tube (61273). Hold bushing of 90554 and unscrew extension tube (61273).

Center extension tube (61273) between end of piston bushing and plunger (11724). Insert any pointed tool in crosser.

Note: Plunger may unscrew from plunger rod (11723) or plunger rod may unscrew from check seat (11726). Extension tube (61273) can be removed from free end of plunger rod (11723).

- See Fig. C. Removal of extension tube (61273) exposes the check seat (11725), priming check (11721), check stop (11722), support bushing (11702) and plunger packing (35073).

Note: Unscrew priming check (11721) from check stop (11722) to remove support bushing (11702) and plunger packing (35073).

- See Fig. D and E. Hold pump tube and unscrew bushing of 90554. Grip two flats at top of plunger with an end wrench and remove check seat (11726).

Note: Check ball (66010) may remain in plunger after check seat (11726) is removed. To remove check ball lift pump in vise and gently tap top of plunger at location of two flats.

- See Fig. F. Remove pump tube from outlet body. Remove piston rod from piston rod connector (11349). Milled flats are provided so that parts can be held with open end wrenches. Remove piston rod connector (11349) and trip rod (90691) from the air motor piston rod (11340) in the same manner. Remove air motor piston rod (11340) as stated in Step No. 8. Replace gasket (31048) between piston rod and piston rod connector (11349). Replace pump tube gasket (31054).

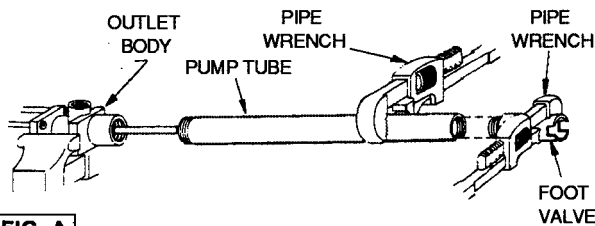
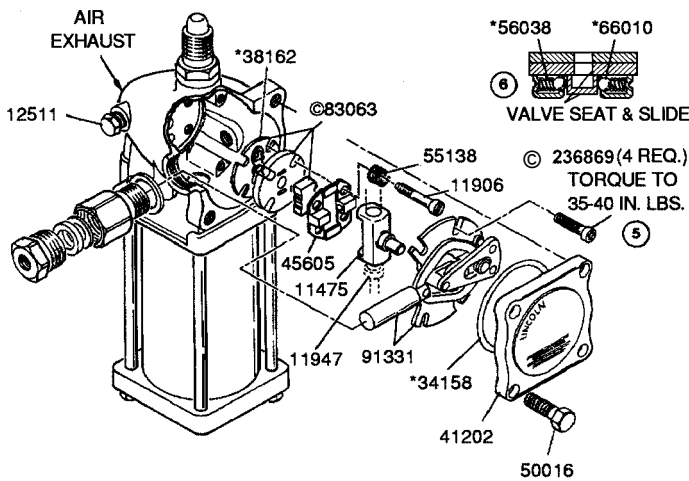

FIG. A

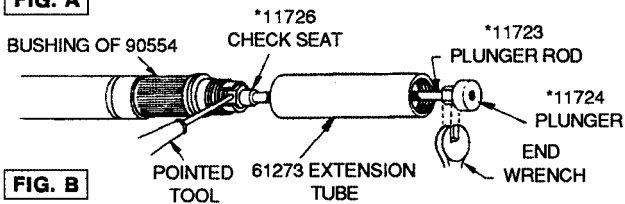

FIG. B

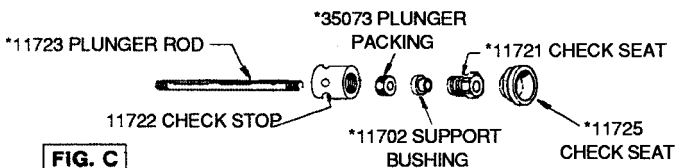

FIG. C

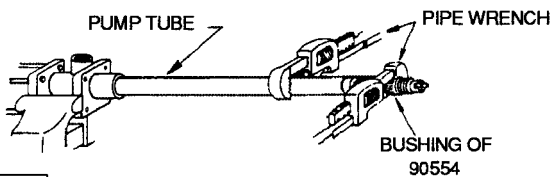

FIG. D

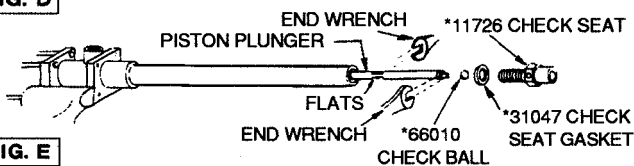

FIG. E

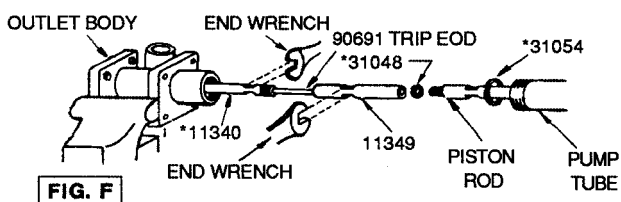
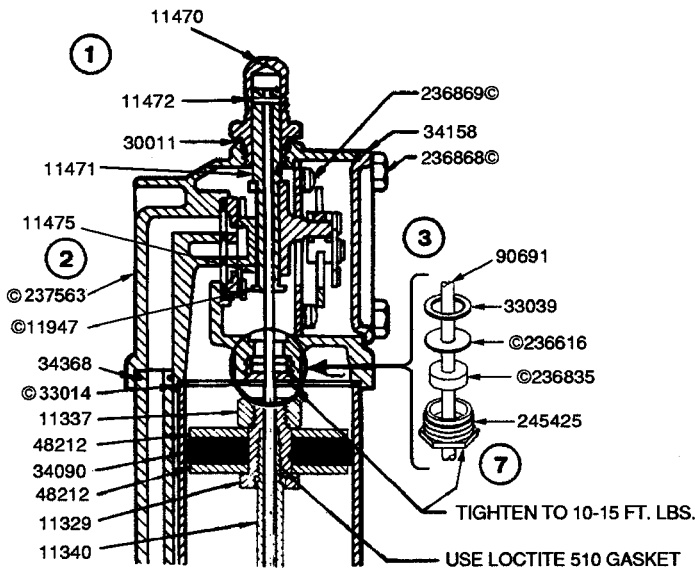

FIG. F

NEW STYLE



NOTE: © INDICATES CHANGE.
START FASTENERS BY HAND TO PREVENT STRIPPING
THREADS WHEN REASSEMBLING.

1. Remove valve cap (11470).
2. Drive trip rod pin (11472) from collar (11471). Collar is free to be removed. Turn trip sleeve (11947) counter-clockwise by hand to unscrew from trip rod (90691).
3. Unscrew four tie rod nuts (51009) from tie rods (10294) and lift entire air motor straight up until free of trip rod (90691).
4. Unscrew four screws (236868) and remove cover (236286). Replace cover gasket (34158).
5. Remove packing cap (11905) and replace plunger packing (34110). Coat the inside surface of packing nut (11904) and the outside surface of the new gasket with lubricant before assembly. Replace packing nut gasket (30003). Remove four toggle plate screws (236869). Lift out toggle assembly (91331) to inspect. Replace if pins are worn out of round or plates are loose. Remove trip shoe (11475) and trip sleeve (11947).
6. Remove four valve seat screws (236870) and the valve seat springs (55138). Remove valve seat guide plate (45605), replace the two steel balls (66010) and the two springs (56038). Remove valve slide, seat and gasket (83063). Inspect for wear and replace if worn.
7. Remove trip rod packing nut (245425), trip rod packing (236835), and trip rod washer (236616), replace packing and gasket. Coat parts with grease.
8. Place outlet body (40537) horizontally in a vise. Remove pump tube from outlet body. Refer to Steps 12 through 16 in OLD STYLE instructions.

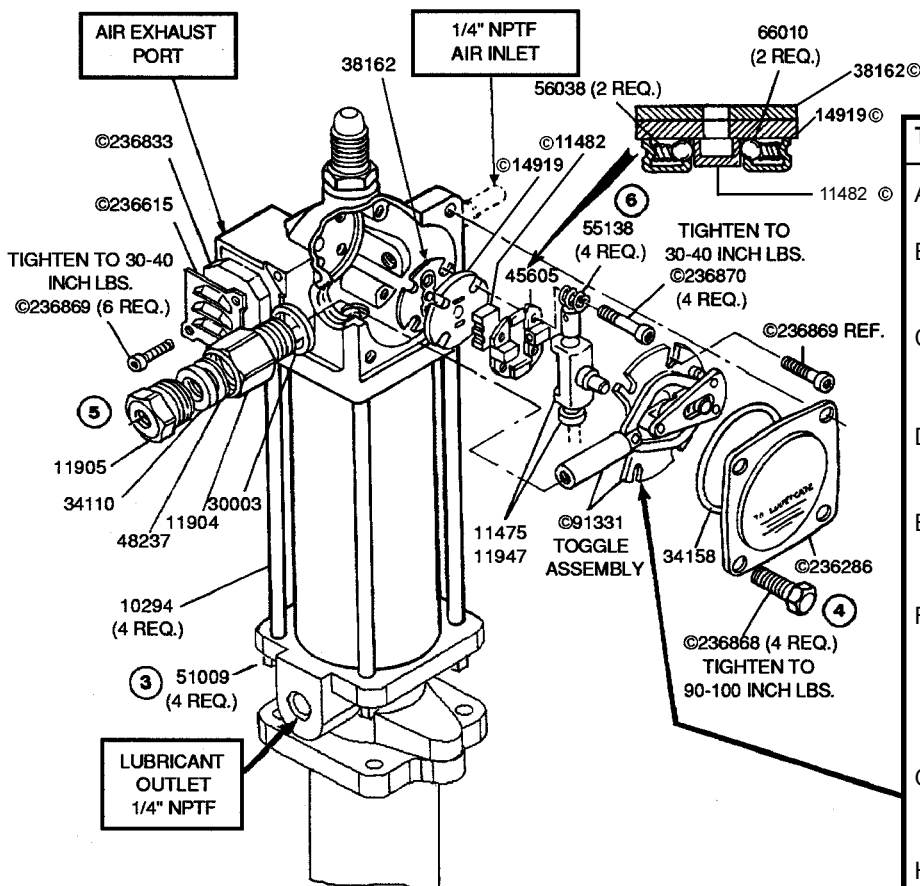

TO LUBRICATE AIR VALVE MECHANISM

- A) DISCONNECT AIR TO PUMP.
- B) PERFORM PRESSURE RELIEF PROCEDURE.
- C) REMOVE FOUR COVER SCREWS, COVER PLATE AND COVER PLATE GASKET.
- D) REMOVE AIR VALVE CASTING FROM THE PUMP AND DISASSEMBLE.
- E) CLEAN OR FLUSH THE AIR VALVE CASTING TO REMOVE ANY CHIPS OR OTHER FOREIGN PARTICLES.
- F) BEFORE REPLACING TOGGLE ASSEMBLY, PACK CAVITY WITH GREASE USING APPROXIMATELY 1-1/2 OUNCES OF N.L.G.I. NO. 1 (LIGHT GRADE) WATER REPELLENT GREASE.
- G) REPLACE COVER PLATE GASKET, COVER PLATE AND COVER CREWS. TIGHTEN TO PREVENT AIR LEAKS.
- H) PERIODIC INSPECTION OF PARTS AT LEAST ONCE A YEAR IS ADVISED.

© Indicates change.

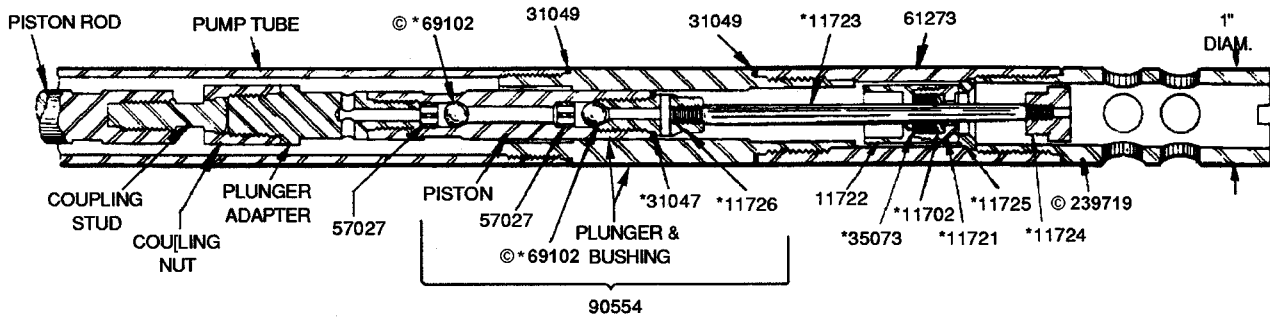

LOWER PUMP TUBE

Pump	Piston Rod	Pump Tube	Coupling Stud	Coupling Nut	Plunger Adapter
81685	11799	61293	11346	11345	11344
81941	—	61321	12209	12211	12210
81985	11727	61272	11346	11345	11344
82050	13020	61407	11346	11345	11344
82054	11761	61285	11346	11345	11344
82716	—	61321	12209	12211	12210
83121	13020	61407	11346	11345	11344
83127	11761	61285	11346	11345	11344
83513	11799	61293	11346	11345	11344

SERVICE PARTS

PART	DESCRIPTION	PART	DESCRIPTION	PART	DESCRIPTION
10294	Tie rod	*30011	Valve cap gasket	50016	Valve cover screw
11329	Air piston bolt	*31047	Check seat gasket	51009	Tie rod nut
11337	Air piston nut	*31048	Connector gasket	*55137	Trip rod packing spring
*11340	Airmotor piston rod	31049	Bushing gasket	55138	Valve seat spring
11349	Piston rod connector	*31050	Gland gasket	*56038	Spring
11470	Valve Cap	*31054	Pump tube gasket	57027	Ball stop
11471	Trip rod collar	*32017	Gasket	61041	Air cylinder
*11472	Trip rod pin	*33014	Air cylinder gasket	61273	Bushing extension
11475	Trip shoe	*33039	Gasket	61502	Air passage tube
©11482	Valve slide	34090	Air piston packing	68531	Eye bolt
*11702	Check washer	*34110	Plunger packing	©*69102	Steel ball
*11721	Priming check	*34158	Cover gasket	90554	Plunger & bushing assy.
11722	Check stop	*34180	Gland packing	90691	Trip rod
*11723	Plunger rod	*34368	O-ring	91331	Toggle assembly
*11724	Priming plunger	*34572	O-ring	236286	Cover
*11725	Priming check seat	*35073	Swivel packing	236615	Muffler cover
*11726	Check seat	*38162	Valve seat gasket	*236616	Trip rod washer
11904	Packing nut	*38165	U-cup packing	236833	Muffler packing
11905	Packing cap	40537	Outlet body	*236835	Trip rod packing
11947	Trip sleeve	45605	Valve guide plate	236868	Screw
12333	Gland packing nut	48212	Air piston washer	236869	Toggle plate screw
12511	Pipe plug	48213	Gland packing washer	236870	Valve seat screw
©14919	Valve seat	48235	Packing washer	©237563	Air valve casting
14940	Gland packing spacer	48237	Plunger packing washer	©239719	Priming tube
*30003	Packing nut gasket	48268	Gland packing washer	245425	Trip rod packing nut

Note: Part numbers marked with an asterisk (*) are included in 83054 Repair Kit.

© Indicates change.