

SPECIFICATIONS

Maximum operating air pressure 200 P.S.I.

WARNING
DO NOT OPERATE
THIS UNIT WITH
COMBUSTIBLE GAS

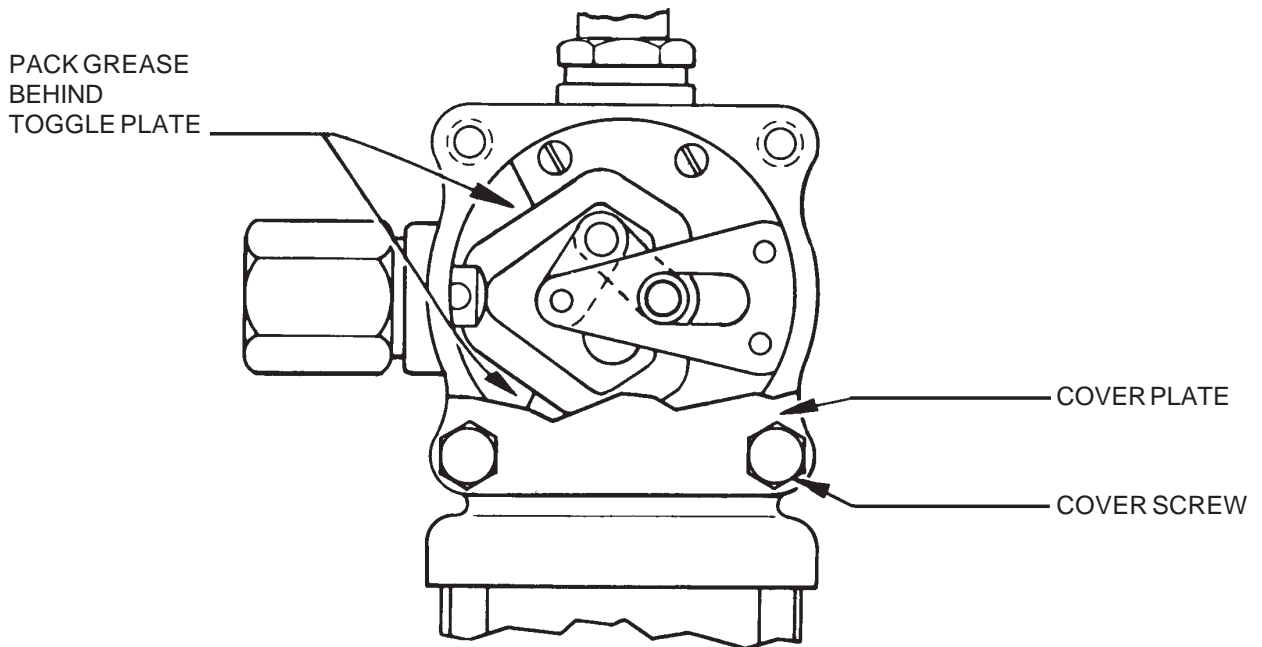

TO LUBRICATE AIR VALVE MECHANISM

Disconnect air to pump. Remove the four Cover Screws, Cover Plate and Cover Plate Gasket. Remove and disassemble the Air Valve casting from the Air Motor. The Air Valve Casting should be cleaned or flushed to remove any chips, or other foreign particles prior to reassembly.

Before replacing the Toggle Assembly, pack cavity with grease. Use N.L.G.I. No. 1 (light grade) water repellent grease, approximately 1½ ounces. Replace Cover Gasket, Cover and Screws, tighten to avoid air leaks.

Periodic inspection of parts at least once each year is advisable.

Model 82737 POWER-MASTER AIR MOTOR

NOTE:

When assembling Air Motor to pump tube, loosen the four bolts holding Air Motor to pump tube. Apply approximately 50 P.S.I.G. air pressure to Air Motor and run pump for several strokes to ensure there is no misalignment between Air Motor and pump tube. Tighten bolts holding Air Motor to pump tube.

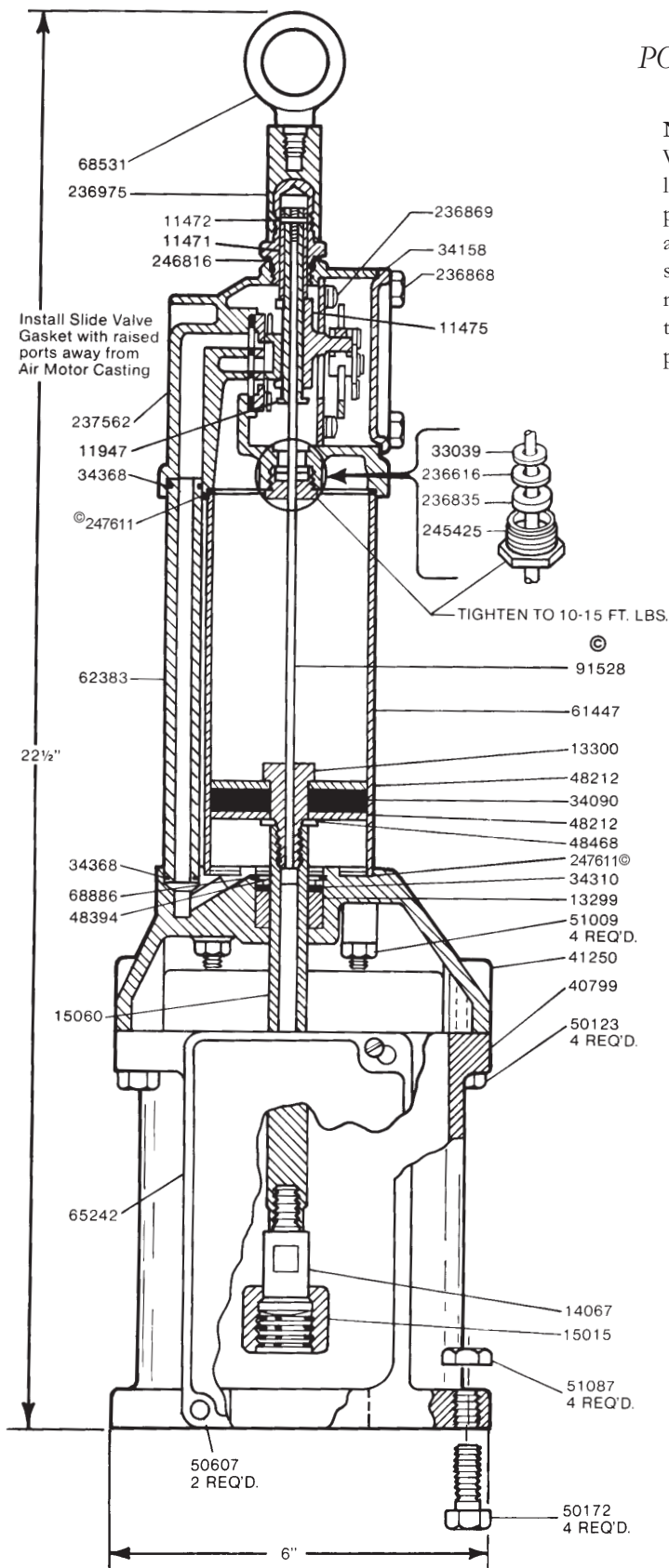

Model 82737
POWER-MASTER AIR MOTOR

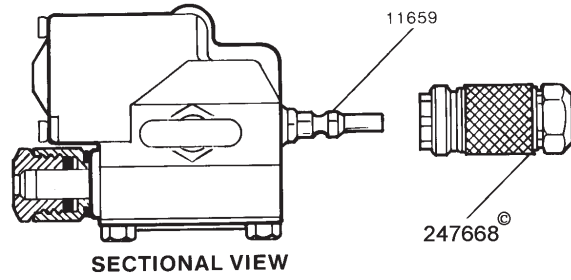

© Indicates change

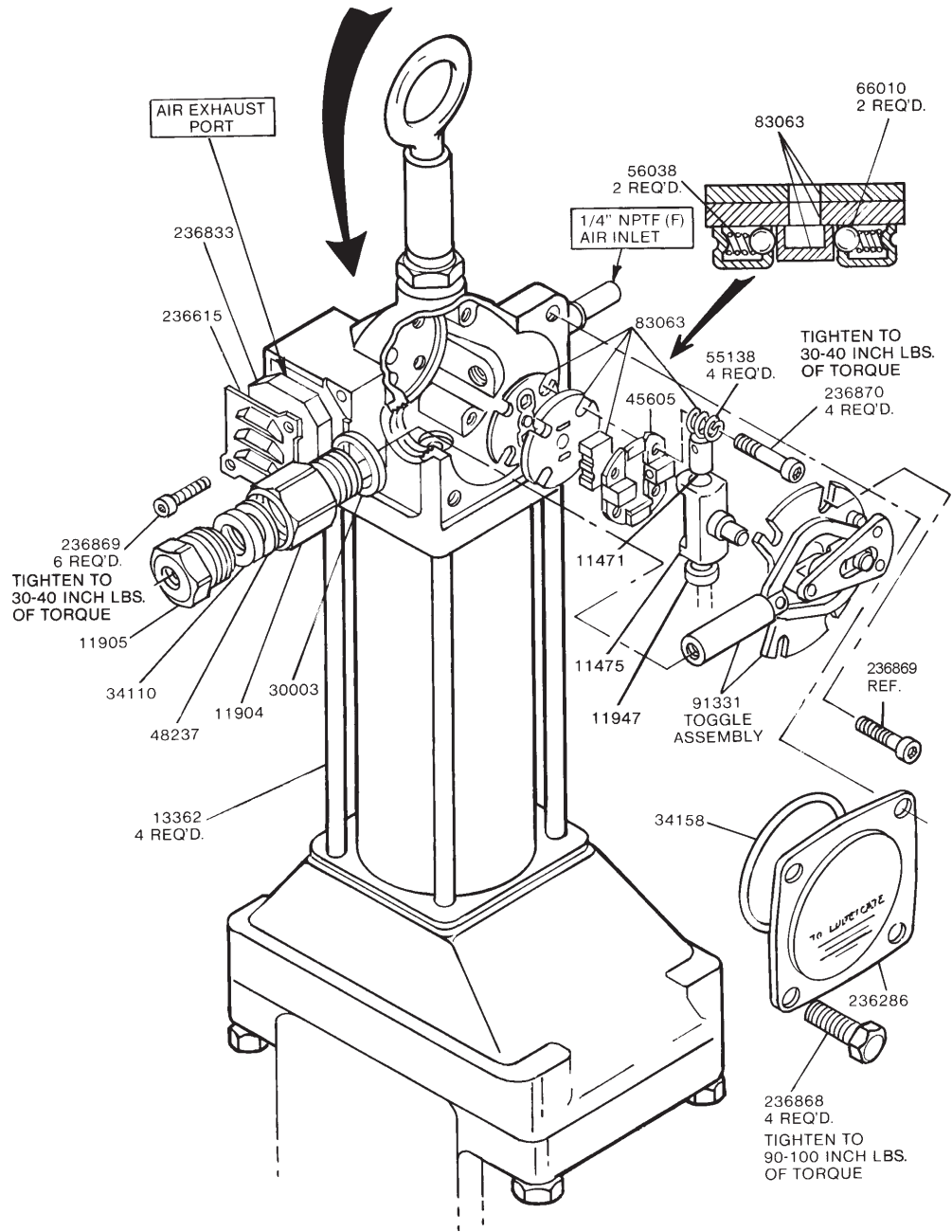

SERVICE PARTS

Part	Description	Part	Description
11471	Trip rod collar	51009	Tie rod nut
†* 11472	Trip rod pin	51087	Nut
11475	Trip shoe	†* 55137	Spring
11659	Air coupler nipple	55138	Valve seat spring
11904	Packing nut	†* 56038	Spring
11905	Packing cap	61447	Air cylinder
11947	Trip sleeve	62383	Air passage tube
13299	Spacer	65242	Serial plate
13300	Piston bolt	†* 66010	Equalizer ball
13362	Tie rod	68531	Eye bolt
14067	Coupling stud	68886	Retaining ring
15015	Coupling nut	* 83063	Slide valve & springs
†* 15060	Piston rod	* 91331	Toggle plate assembly
†* 30003	Packing nut gasket	91528	Trip rod
†* 33039	Gasket	236286	Cover
* 34090	Air piston packing (Nitrile)	236615	Muffler cover
†* 34110	Plunger packing (Nitrile)	* 236616	Packing nut gasket
†* 34158	Cover gasket (Neoprene)	236833	Muffler
†* 34310	Packing (Nitrile)	†* 236835	Trip rod packing (Nitrile)
†* 34368	O-ring (Nitrile)	236868	Valve cover screw
†* 38162	Valve seat gasket	236869	Toggle plate screw
40799	Air motor support casting	236870	Valve seat bolt
41250	Cylinder head casting	236975	Extension adapter
45605	Valve guide plate	237562	Air valve casting
48212	Air piston washer	†* 244313	Seat
48237	Plunger packing washer	†* 244359	O-ring (Nitrile)
48394	Washer	* 245425	Trip rod packing nut
48468	Washer	†* 246816	Valve cap gasket
50123	Hex. head screw	†* 247611	Air cylinder gasket © (Nitrile Coated Fiber)
50172	Bolt		Air Coupler ©
50607	Round head screw	247668	

* Recommended Service Parts Inventory.

† Included in 83034 Repair kit.

© Indicates change

RETAIN THIS INFORMATION FOR FUTURE REFERENCE

When ordering replacement parts, list: Part Number, Description, Model Number, and Series Letter.

LINCOLN provides a Distributor Network that stocks equipment and replacement parts.