

82737

WARNING
DO NOT OPERATE
WITH COMBUSTIBLE GAS

PILE DRIVER PUMPS

(BALL TYPE FOOT VALVE)

AIRMOTOR MODELS

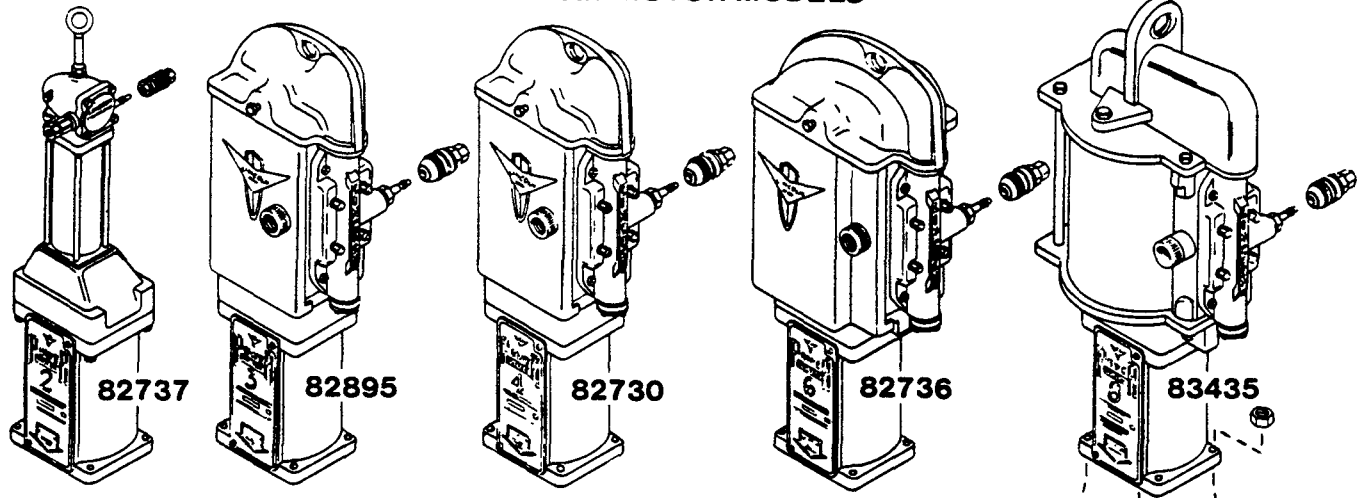

ATTACHING AIRMOTOR TO PUMPTUBE

- 1- Tightly connect airmotor coupling nut to pump plunger.
- 2- Attach airmotor to the pump outlet body flange with the four bolts and nuts (hand tight) supplied with airmotor.
- 3- Slowly cycle the pump several times, using just enough air pressure to operate the pump without stalling.
- 4- Stop the pump on an "up" stroke and tighten the four bolts and nuts to securely fasten the airmotor to the pumptube.

GLAND PACKING LUBE WELL

Many materials such as ink, undercoating, buffing compounds, etc. tend to build up and dry out on the pump rod. This causes the gland packings to wear out rapidly. To prevent material buildup on the pump rod, fill the lube well with a fluid compatible with the material that is to be pumped.

The lube well is accessible for inspection and filling by removing the Power-Master name plate from the side of the airmotor.

CAUTION: Do not fill lube well to full capacity as the reciprocating movement of the airmotor piston rod may draw the fluid into the airmotor.

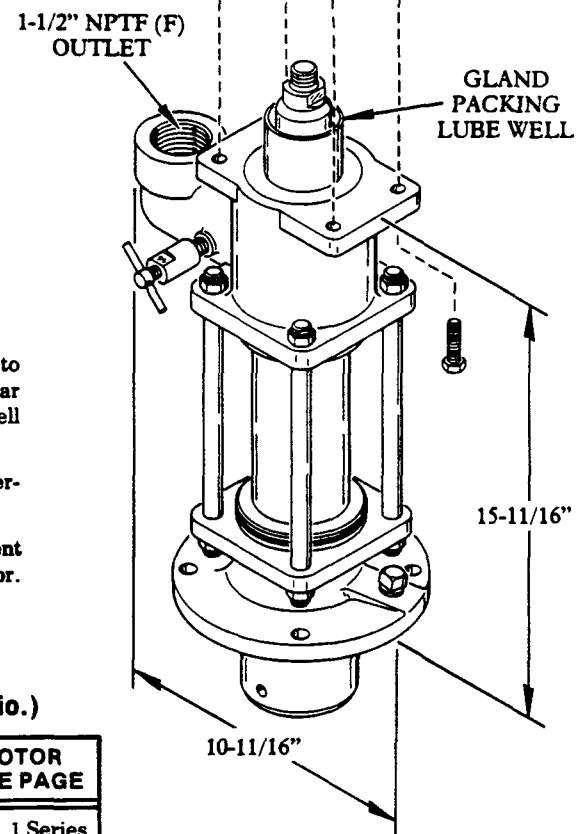

83602 PUMPTUBE ASSEMBLY Series "B"

MODEL CHART

(*Size of airmotor used with pumptube determines pump ratio.)

PUMPTUBE	PUMP MODEL	*RATIO	MAXIMUM AIR PRESSURE	AIRMOTOR	AIRMOTOR SERVICE PAGE
83602	2201	1.5:1	200 psi	82737	A-50, Pg. 1 Series
	2221	2.5:1	200 psi	82895	A-50, Pg. 3 Series
	2241	5:1	200 psi	82730	A-50, Pg. 3 Series
	2261	10:1	100 psi	82736	A-50, Pg. 3 Series
	2281	18:1	100 psi	83435	A-50, Pg. 6 Series



A PENTAIR COMPANY

One Lincoln Way
St. Louis, MO 63120-1578
(314) 679-4200
Customer Service, (314) 679-4300

SECTION - **A50**
PAGE - **39D**

SERVICE OF LOWER PUMPING UNIT

Loss of volume and pressure or continuous operation of pump when not in normal use indicates:

- 1) Material supply in drum may not be adequate.
- 2) Air supply may not be adequate. Check setting of air supply line regulator.
- 3) Pump may operate on down stroke only, due to material by-passing the 14356 Check and piston. Remove and clean parts. Inspect seating surfaces for wear. Replace if necessary.
- 4) Material by-passing the piston packings. 34513 U-cup Packings may be worn or damaged. Replace packings. Inside of pump tube may be scored or rough. Remove and inspect pump tube. If area inside of tube where piston packings travel is scored or rough, replace the pump tube.
- 5) Pump is operating but not dispensing material. 69150 Ball Check in foot valve is not seating. Inspect ball check and seat for foreign particles or wear. Also inspect 34414 O-ring in check seat. Replace parts if necessary.
- 6) Material by-passing 34514 U-cup Packing in gland assembly. Replace packing.
- 7) Plunger may be scored, pitted or worn. Replace plunger.

NOTE: 69278 Adjustable Spanner Wrench and 69294 Face Spanner Wrench are available for service of pumptube assembly.

83602 PUMPTUBE ASSEMBLY Series "B"

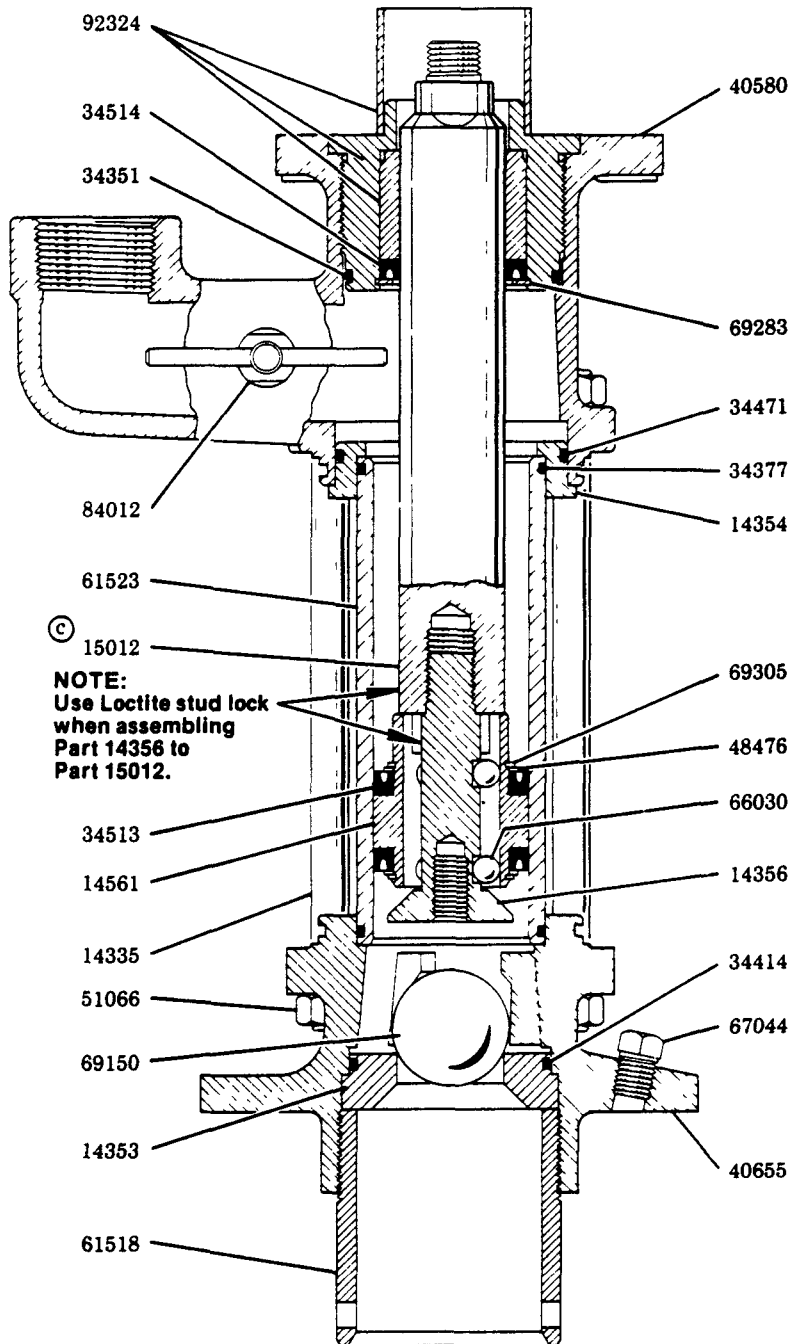

OPTIONAL: 83980 Teflon Packing Conversion Kit.
Refer to Service Manual
Section K4, Pg. 23 Series.

© Indicates change

SERVICE PARTS

PART	QUAN.	DESCRIPTION
14335	4	Tie rod
*14353	1	Check seat
14354	1	Adapter ring
14356	1	Check
*14561	1	Piston
*15012	1	Plunger
*34351	1	O-ring
*34377	2	O-ring
*34414	1	O-ring
*34471	1	O-ring
*34513	2	U-cup packing (Polyurethane)
*34514	1	U-cup packing (Polyurethane)
40580	1	Outlet body
40655	1	Adapter plate
48476	2	Washer
51066	8	Nut
61518	1	Tube
61523	1	Pump tube
66030	6	Ball
67044	1	Pipe plug
*69150	1	Ball
69283	1	Retaining ring
69305	2	Retaining ring
84012	1	Bleeder valve
92324	1	Bushing & gland nut assembly

*Recommended service parts inventory.

RETAIN THIS INFORMATION FOR FUTURE REFERENCE

When ordering replacement parts, list: Part Number, Description, Model Number, and Series Letter.

LINCOLN provides a Distributor Network that stocks equipment and replacement parts.
A list of Authorized Service Departments will be furnished upon request.