

MAX. AIR PRESSURE - 100 PSI

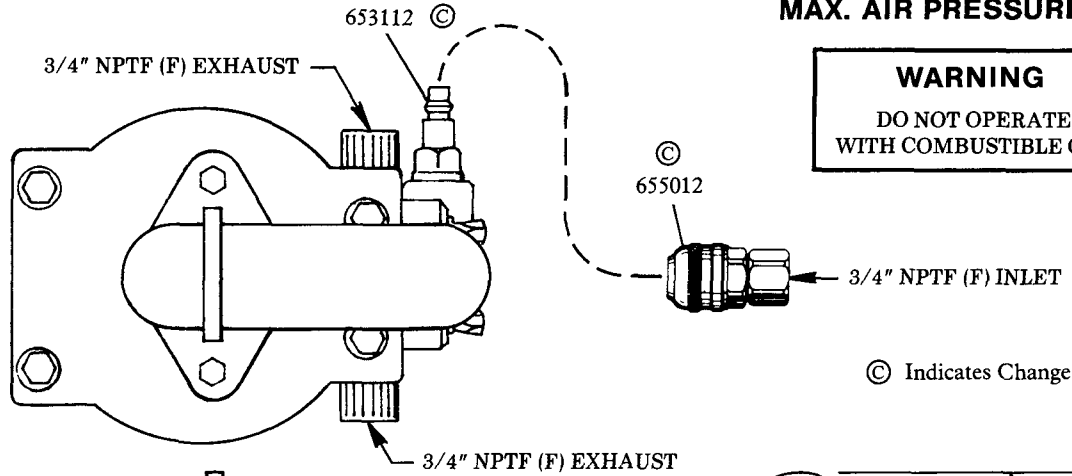

WARNING
DO NOT OPERATE
WITH COMBUSTIBLE GAS

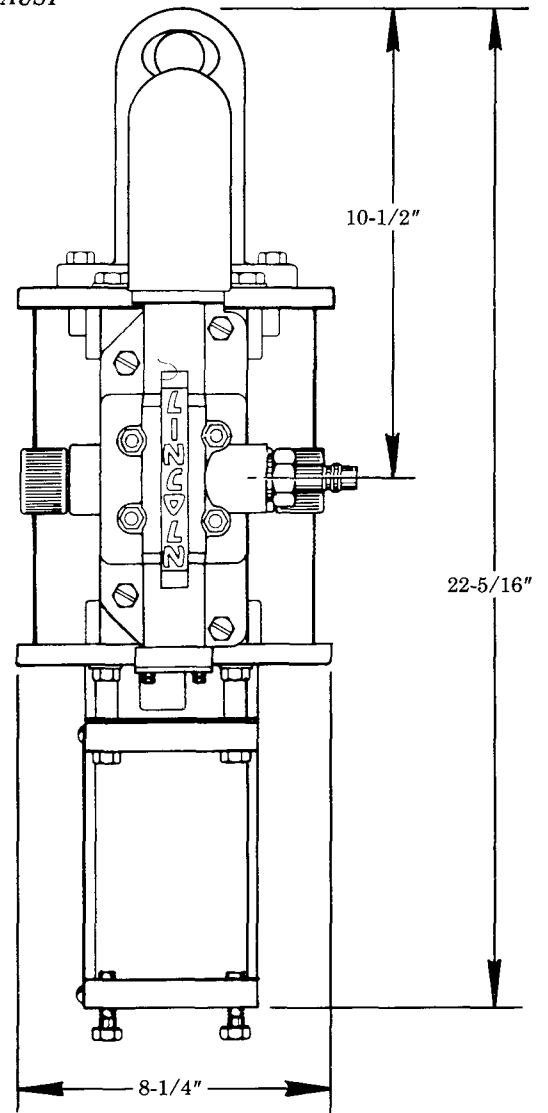

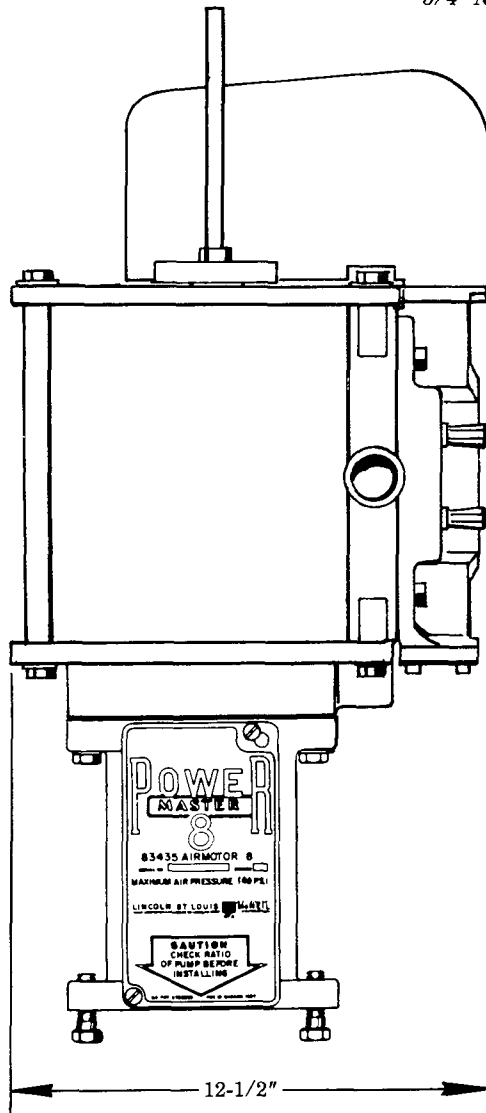
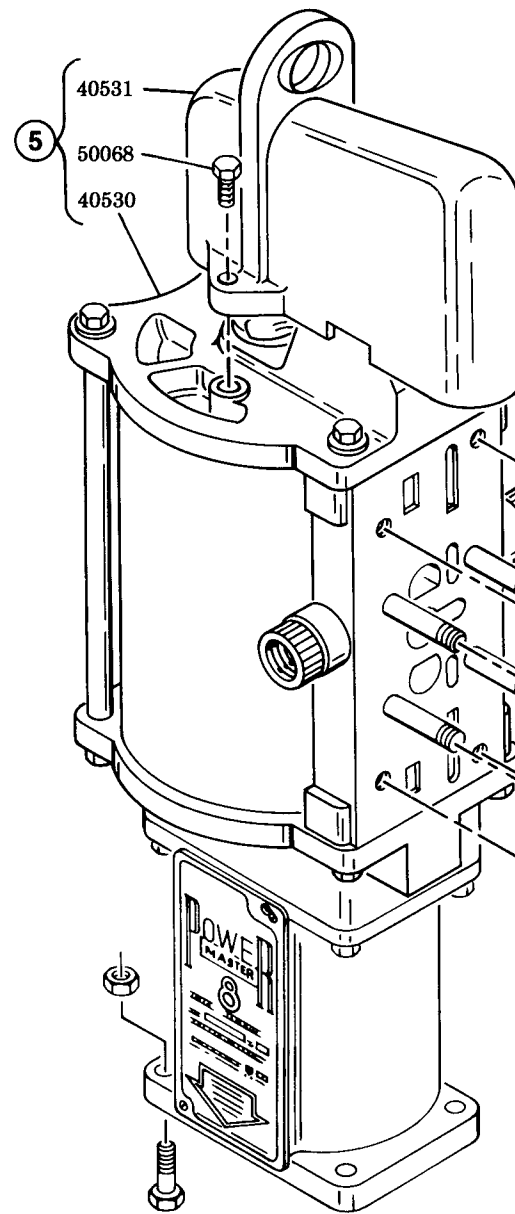

IMPORTANT
When assembling the air valve components, make sure that the power slide valve, pilot slide valve and the valve actuator are in their "down" positions. The valve actuator should bridge the slide valves without interference. (Refer to the right-hand illustration.)
If the 13212 Acorn Nuts are tightened with the valve parts misaligned, the 13942 Valve Actuator will be bent and the 41230 Valve Body will be ruined.

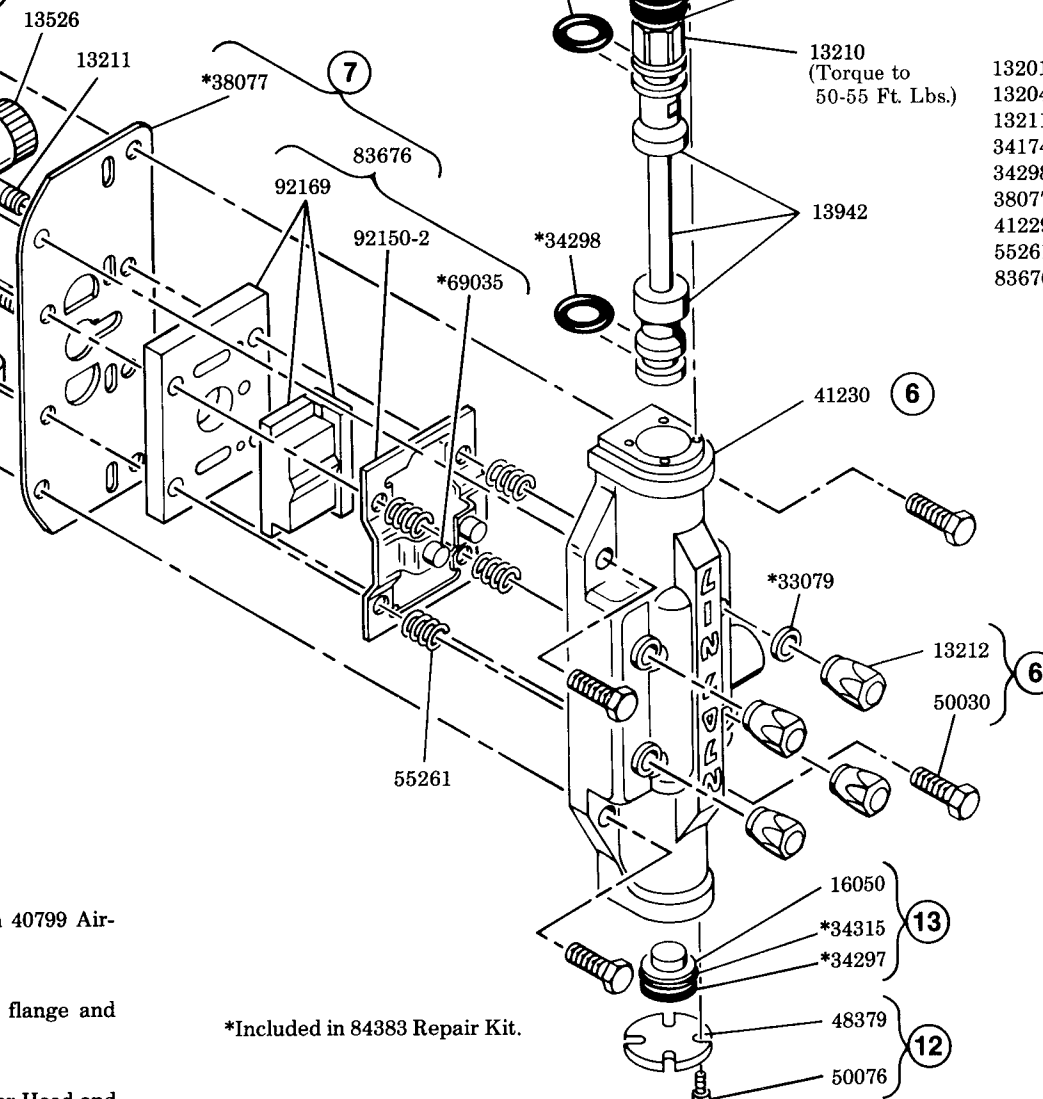

DISASSEMBLY PROCEDURE

- 1) Remove 50607 Screws and 65243 Nameplate from 40799 Airmotor Support Casting.
- 2) Unscrew 15015 Coupling Nut from pump plunger.
- 3) Remove 50172 Bolts and 51087 Nuts from pump flange and airmotor support casting.
- 4) Lift airmotor off of pumptube.
- 5) Unscrew two 50068 Bolts from 40530 Upper Cylinder Head and lift off 40531 Cover Casting.
- 6) Remove 13212 Acorn Nuts and 50030 Screws from 41230 Valve Body.
- 7) Remove 83376 Air Valve Assembly, 83676 Slide Valve Assembly and 38077 Valve Gasket.
- 8) Unscrew four 50076 Screws from top of valve body.
- 9) Lift up on 13201 Trip Rod Collar and pull 13204 Trip Rod and attached parts from valve body.
- 10) Remove 68476 Retaining Ring and 13213 Pin from trip rod collar.
- 11) Unscrew trip rod collar from trip rod and remove 14363 Trip Rod Guide, 34448 Packing and 48473 Packing Washer. (Thread packing off of trip rod.)
- 12) Unscrew four 50076 Screws from bottom of valve body and remove 48379 Washer.

- 13) Tap 16050 Spacer and 34297 Packing out through bottom of valve body.
- 14) Remove 68476 Retaining Ring and 13213 Pin from other 13201 Trip Rod Collar.
- 15) Unscrew trip rod collar from 13202 Trip Rod. (It may be necessary to push trip rod down to remove trip rod collar.)
- 16) Unscrew four 50032 Bolts from 40530 Upper Cylinder Head and remove upper cylinder head.
- 17) Unscrew four 50076 Screws from upper cylinder head and remove 48377 Washer, 34448 Packing and 14364 Trip Rod Guide.
- 18) Unscrew four 50032 Bolts from 40557 Lower Cylinder Head and remove 41229 Support and 13207 Tie Rods.
- 19) Remove 61673 Air Cylinder. (When reassembling air cylinder, use caution to avoid damage to 34397 O-rings.)

- 20) Hold 14244 Piston Rod on wrench flats and loosen 14243 Trip Rod Stop. (Do Not Remove.)
- 21) Unscrew 11083 Coupling Stud from piston rod using wrench flats.
- 22) Remove 40556 Piston and piston rod from lower cylinder head.
- 23) Unscrew trip rod stop and remove trip rod and piston from piston rod. (Thread piston off of piston rod to avoid damage to 34353 O-ring.)
- 24) Remove 69005 Retaining Ring, 48462 Washer, 34435 Packing and 14242 Bearing through top of lower cylinder head.
- 25) To reassemble reverse procedure.

NOTE: If complete disassembly is required, replace all gaskets, o-rings and packings. (Order 84383 Repair Kit.)

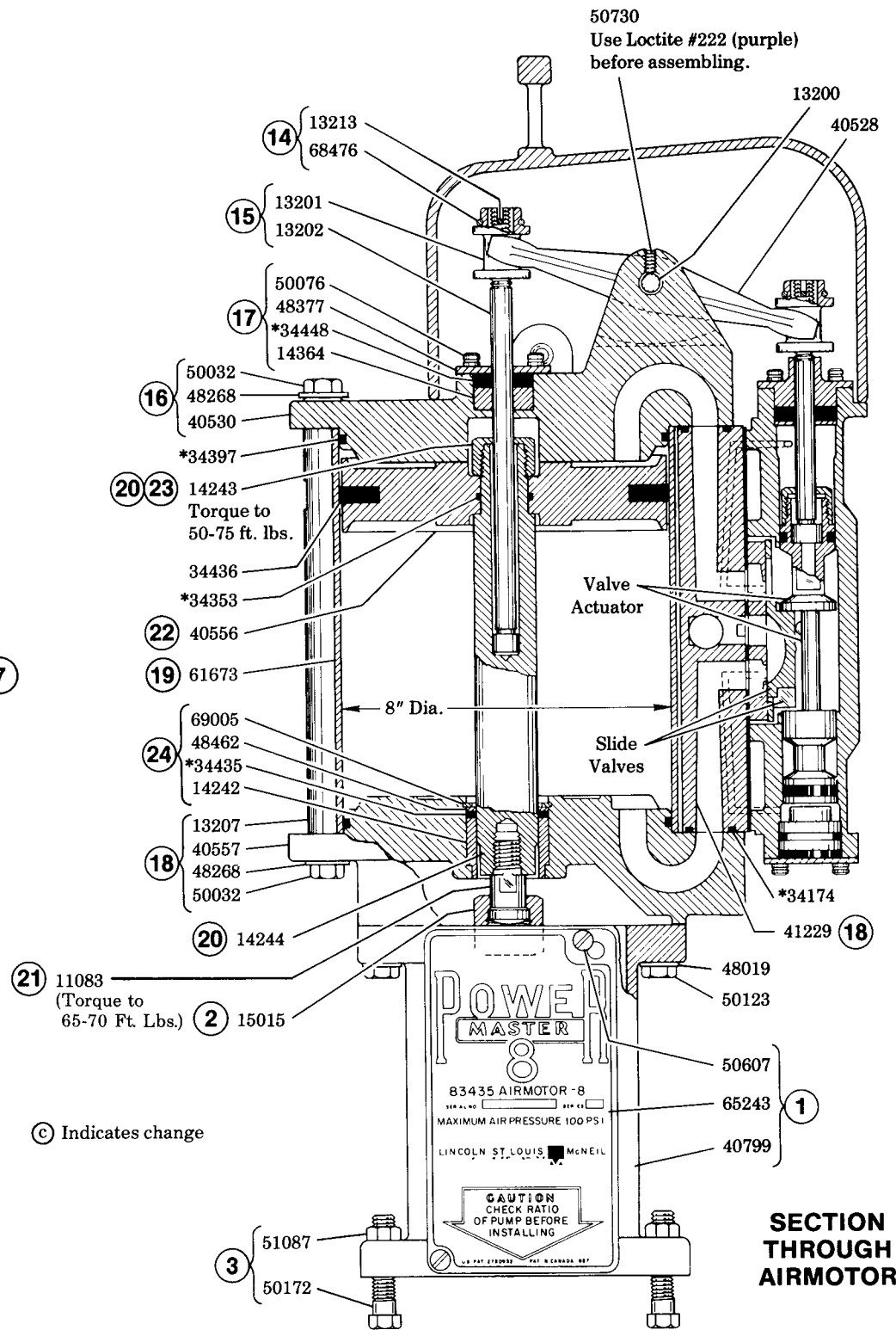

Ⓢ Indicates change

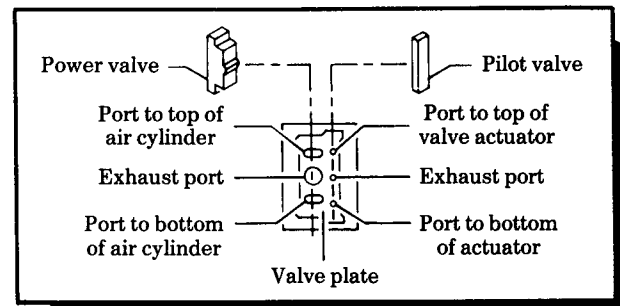

POWER & PILOT VALVES & AIR PASSAGE PORTS IN VALVE PLATE

ATTACHING AIRMOTOR TO PUMPTUBE

- 1) Tightly connect airmotor coupling nut to the pump plunger.
- 2) Attach airmotor to the pump outlet body flange with the four bolts and nuts (hand tight) supplied with airmotor.
- 3) Slowly cycle the pump several times, using just enough air pressure to operate the pump without stalling.
- 4) Stop the pump on an "up" stroke and tighten the four bolts and nuts to securely fasten the airmotor to the pumptube.

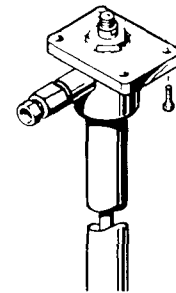
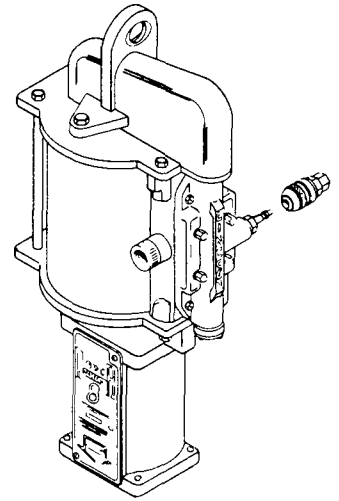

TROUBLESHOOTING

Problem	Solution
1) Airmotor does not operate.	Check air supply to pump. Check 92169 Valve & Seat. If rusted or scored, replace. Check for broken 13202 or 13204 Trip Rod, replace.
2) Air leakage at top of cylinder.	Replace 34448 Packing. Check 13202 Trip Rod. If scored, replace trip rod.
3) Air leakage at bottom of cylinder.	Replace 34435 Packing. Check 14244 Piston Rod. If scored, replace piston rod.
4) Air leakage at top of valve body.	Replace 34448 Packing. Check 13204 Trip Rod. If scored, replace trip rod.
5) Air leakage from exhaust.	Check 92169 Valve & Seat. If rusted or scored, replace. Replace 34298 Packings. Check inside diameter of 41230 Valve Body. If scored, replace 83376 Air Valve Assembly.
6) Airmotor ices up and stalls frequently under continuous operation.	Install airline filter. (Above item must be ordered separately.)

SERVICE PARTS

Part	Qty.	Description	Part	Qty.	Description	Part	Qty.	Description
11083	1	Coupling stud	*34298	2	Packing (buna-N)	50030	4	Screw
13200	1	Pin	*34315	1	O-ring (buna-N)	50032	8	Bolt
13201	2	Trip rod collar	*34353	1	O-ring (buna-N)	50068	2	Bolt
13202	1	Trip rod	*34397	2	O-ring (buna-N)	50076	12	Screw
13204	1	Trip rod	*34435	1	Packing (buna-N)	50123	4	Bolt
13207	2	Tie rod	34436	1	Piston packing (buna-N)	50172	4	Bolt
13210	1	Trip rod stop	*34448	2	Packing (buna-N)	50607	2	Screw
13211	4	Stud	*38077	1	Valve gasket (buna-N on nylon)	50730	2	Set screw
13212	4	Acorn nut	40528	1	Rocker arm	51087	4	Nut
13213	2	Pin	40530	1	Upper cylinder head	55261	4	Spring
13526	2	Adapter	40531	1	Cover casting	61673	1	Air cylinder
13942	1	Valve actuator	40556	1	Piston	65243	1	Nameplate
14242	1	Bearing	40557	1	Lower cylinder head	68476	2	Retaining ring
14243	1	Trip rod stop	40799	1	Airmotor support casting	69005	1	Retaining ring
14244	1	Piston rod	41229	1	Support	*69035	2	Catch
14363	1	Trip rod guide	41230	1	Valve body	83376	1	Air valve assembly
14364	1	Trip rod guide	48019	4	Washer	83676	1	Slide valve assembly
15015	1	Coupling nut	48268	8	Washer	92150-2	1	Guide plate
16050	1	Spacer	48377	1	Washer	92169	1	Valve & seat
*33079	4	Gasket (fibre)	48379	1	Washer	653112	1	Air nipple
*34174	2	O-ring (buna-N)	48462	1	Washer	655012	1	Air coupler
*34297	1	Packing (buna-N)	48473	1	Packing washer			

*Included in 84383 Repair Kit.

RETAIN THIS INFORMATION FOR FUTURE REFERENCE

When ordering replacement parts, list: Part Number, Description, Model Number, and Series Letter.

LINCOLN provides a Distributor Network that stocks equipment and replacement parts.