

# Model Nos. 84900, 84901, 84902 PILE DRIVER III PUMP ASSEMBLY Series "B"

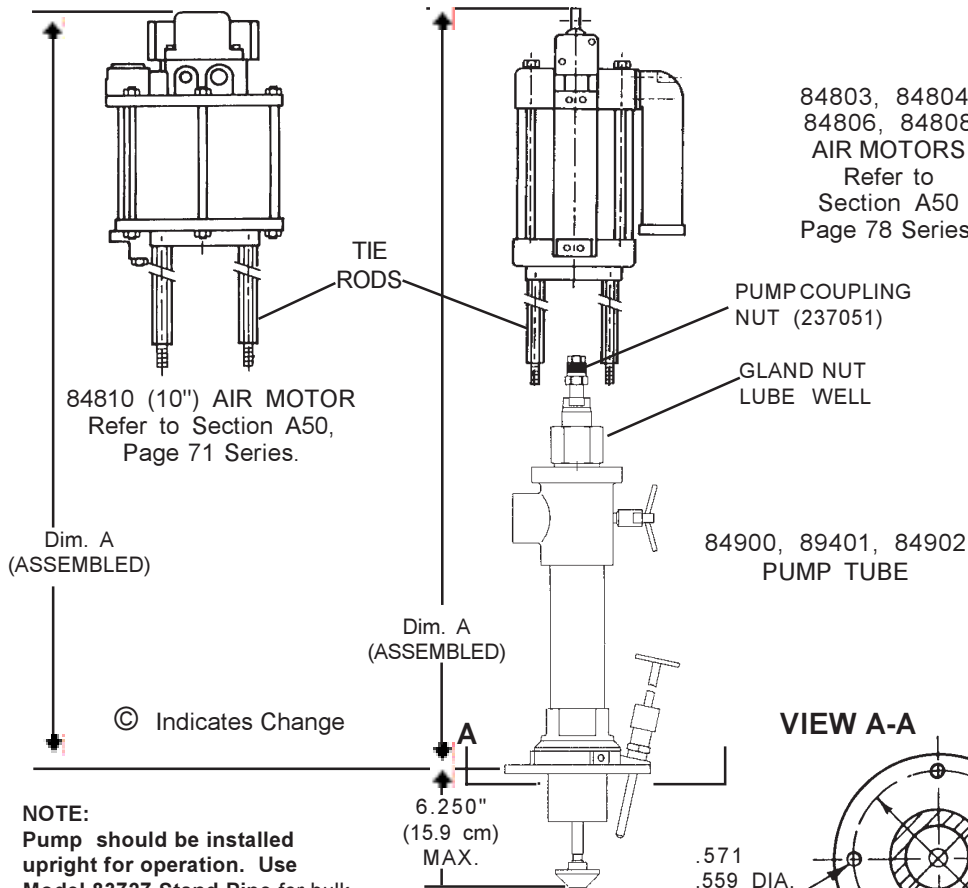

**PILE DRIVER III  
PUMP ASSEMBLY**  
94804, 94806,  
94808  
AIR MOTORS®  
with AIRBRAKE  
Refer to  
Section A50  
Page 84 Series.

84803, 84804,  
84806, 84808  
AIR MOTORS  
Refer to  
Section A50  
Page 78 Series.

**WARNING**  
DO NOT OPERATE  
WITH COMBUSTIBLE GAS

**WARNING**  
KEEP HANDS AWAY FROM  
PUMP OUTLET WHILE AIRLINE  
IS CONNECTED. DONOT  
OPERATE PUMP UNLESS IT IS  
FIRMLY MOUNTED ONTO  
PRESSURE PRIMER OR  
STANDPIPE AND AREA  
AROUND PUMP INLET IS  
CLEAR OF OBSTRUCTIONS.

**NOTE:**  
Pump should be installed  
upright for operation. Use  
Model 83727 Stand Pipe for bulk  
material dispensing. Locate pump  
as close to tank as possible and  
use a minimum of 3 inch (76 mm)  
I.D. inlet hose or pipe.

## MODEL CHART

PUMP TUBE	PUMP MODEL	AIR MOTOR	RATIO	MAXIMUM DELIVERY PRESSURE	MAXIMUM AIR PRESSURE	DIMENSION "A" IN. (CM.)
84900	2342	84810	42:1	4200 psi (290 bar)	100 psi (7 bar)	42-1/4 (107.3)
	2325	84808	25:1	2500 psi (172 bar)		39-7/8 (101.3)
	2352	84806	15:1	1500 psi (104 bar)	200 psi (14 bar)	40-3/4 (103.5)
	2367	84804	7:1	1400 psi (97 bar)		40-3/4 (103.5)
	2374	84803	3:1	600 psi (41 bar)		40-3/4 (103.5)
84901	2355	84810	55:1	5500 psi (379 bar)	100 psi (7 bar)	42-1/4 (107.3)
	2323	84808	35:1	3500 psi (241 bar)		39-7/8 (101.3)
	2350	84806	20:1	2000 psi (138 bar)	200 psi (14 bar)	40-3/4 (103.5)
	2365	84804	10:1	2000 psi (138 bar)		40-3/4 (103.5)
84902	2372	84803	4:1	800 psi (55 bar)	100 psi (7 bar)	42-1/4 (107.3)
	2375	84810	75:1	7500 psi (517 bar)		39-7/8 (101.3)
	2322	84808	45:1	4500 psi (310 bar)		39-7/8 (101.3)
	2349	84806	25:1	2500 psi (172 bar)	200 psi (14 bar)	40-3/4 (103.5)
	2364	84804	12:1	2400 psi (166 bar)		40-3/4 (103.5)
	2371	84803	6:1	1200 psi (93 bar)		



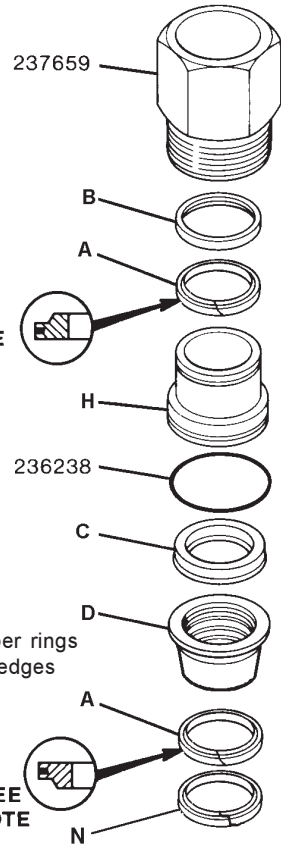
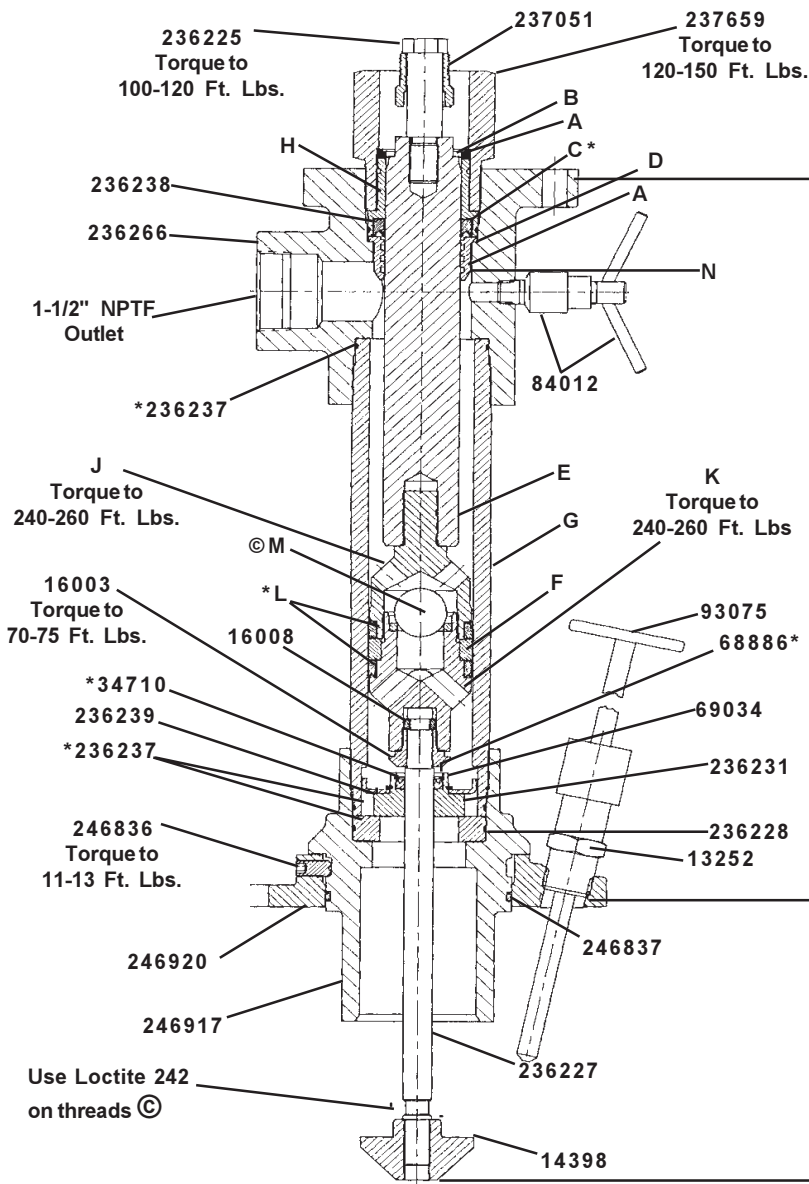

**SERVICE PARTS**

**UNIQUE PARTS (BY MODEL NUMBER)**

ITEM	DESCRIPTION	QTY.	84900	84901	84902
A	Wiper	2	237650	237584	237652
B	Spacer	1	237649	237674	237651
C	U-cup (polyurethane)	1	#*237007	#*34701	#*34421
D	Sleeve	1	247267 (Stamped "J")	247268 (Stamped "K")	247269 (Stamped "L")
E	Plunger	1	237006 (1-1/4" flats)	236232 (1-1/8" flats)	237042 (1" flats)
F	Piston Collar	1	246905	246908	246911
G	Pump Tube	1	237012	236257	237049
H	Bushing	1	237005	236234	237044
J	Piston Nut	1	246903 (1-7/8" flats)	246906 (1-5/8" flats)	246909 (1-3/8" flats)
K	Piston Body (1-1/8" flats)	1	246904	246907	246910
L	U-cup (polyurethane)	2	*237027	*236236	*237068
M	Check Ball	1	246877	68649	246889
N	Retaining Ring	1	247273	247274	247275

\* Included in Seal Kit

#Included in Gland Seal Kit

**COMMON PARTS**

PART	QTY.	DESCRIPTION
13252	1	Connector (1-1/8" hex)
14398	1	Priming Plunger Nut (7/8" flats)
16003	1	Adapter (1-1/8" flats)
16008	2	Keeper
* 34710	1	U-cup (polyurethane)
* 68886	1	Retaining ring
69034	1	Retaining ring
84012	1	Bleeder Valve (3/4"flats)
93075	1	Priming Plug
236225	1	Bolt Connector (7/8" hex)
236227	1	Priming Rod (1/2" flats)
236228	1	Check seat
236231	1	Check
* 236237	3	O-ring (polyurethane)
#* 236238	1	O-ring (polyurethane)
236239	1	Guide Washer
236266	1	Outlet Body
237051	1	Coupling Nut (1-1/8" hex)
237659	1	Gland Nut (2-5/8" hex)
246836	3	Set Screw (3/16" hex socket)
* 246837	1	O-ring (nitrile)
246917	1	Inlet Bushing (3-1/2" flats)
246920	1	Mounting Flange

## TROUBLESHOOTING

Problem	Possible Cause	Solution
Pump does not operate.	Restricted or inadequate air supply.	Check air supply pressure and air hose diameter (see specifications for minimum air supply hose diameter).
	Obstructed material output.	Check output line for restrictions.
Erratic or accelerated operation.	Pump is not primed.	Prime pump (see "pump priming instructions").
	Insufficient material supply.	Refill material supply.
	Material is too heavy for priming.	Lower output with material valve. Increase pressure to pressure primer (if in use). Check for inlet restrictions.
Pump operates on "down" stroke only (missing "up" stroke).	Worn or damaged Piston U-cups (Item L) or Piston Check (Item K and Item M).	Check and replace if needed.
Pump operates on "up" stroke only (missing "down" stroke).	Worn or damaged inlet check(236231) or Priming Rod Packing (34710).	Check and replace if needed.
	Insufficient material supply, pump is not intaking enough material to dispense on both strokes.	Check inlet for restrictions. lower output with material valve.
Pump is operating but not dispensing material.	Inlet check (236231) is not seating or damaged.	Check and replace if needed.

### DISASSEMBLY PROCEDURE

Tools Required	(Used on Part #)
3/16" hex key	(246836)
1/2" wrench	(236227)
3/4" wrench	(84012)
7/8" wrench	(14398 & 236225)
1" wrench	(84902 Item E)
1-1/8" wrench	(13252, 16003, 237051, Item K & 84901 Item E)
1-1/4" wrench	(84900 Item E)
1-3/8" wrench	(84902 Item J)
1-5/8" wrench	(84901 Item J)
1-7/8" wrench	(84900 Item J)
2-5/8" wrench	(237659)
3-1/2" wrench	(246917)
3" dia. strap wrench	(Item G)
Internal retaining ring pliers	(68886)
External retaining ring pliers	(69034)
Two screwdrivers	(Item H) & (Item N)

### PROCEDURE

1. Remove Set Screws (246836) from Mounting Flange (246920).
2. Remove Mounting Flange (246920) from Inlet Bushing (246917).
  - a. Remove Priming Plug (93075) from Connector (13252).
  - b. Remove Connector (13252) from Mounting Flange (246920).
3. Remove Priming Plunger Nut (14398) from Priming Rod (236227).
4. Remove Inlet Bushing (246917) from Pump Tube (Item G).
  - a. Remove O-ring (246837) from Inlet Bushing (246917).
  - b. Remove Check Seat (236228) from Inlet Bushing (246917).
  - c. Remove O-ring (236237) from Check Seat (236228).
5. Remove Bolt Connector (236225) from Plunger (Item E).
  - a. Slide Coupling Nut (237051) off Bolt Connector (236225).
6. Remove priming rod, piston and plunger assembly from bottom of Pump Tube (Item G).
  - a. Remove Adapter (16003) from Piston Body (Item K).
  - b. Remove Keepers (16008) and Adapter (16003) from Priming Rod (236227).
  - c. Remove check assembly from Priming Rod (236227).
  - d. Remove Retaining Ring (69034) and Guide Washer (236239) from Check (236231).
- e. Remove Retaining Ring (68886) and U-cup (34710) from Check (236231).
- f. Remove piston assembly from Plunger (Item E).
- g. Remove Piston Nut (Item J) and Check Ball (Item M) from Piston Body (Item K).
- h. Remove U-cup (Item L) from Piston Nut (Item J).
- i. Remove Piston Collar (Item F) and U-cup (Item L) from Piston Body (Item K).
7. Remove Pump Tube (Item G) from Outlet Body (236266).
  - a. Remove O-rings (236237) from Pump Tube (Item G).
8. Remove Bleeder Valve (84012) from Outlet Body (236266).
9. Remove Gland Nut (237659) from Outlet Body (236266).
  - a. Remove Wiper (Item A) and Spacer (Item B) from Gland Nut (237659).
10. Remove Bushing (Item H) from Outlet Body (236266).
  - a. Remove O-ring (236238) and U-cup (Item C) from Bushing (Item H).
11. Remove Sleeve (Item D), Scraper (Item A), and Retaining Ring (Item N) from Outlet Body (236266).
12. To re-assemble pump, reverse disassembly procedure. (Refer to illustration for torque specifications.)

### PUMPTUBE SERVICE KITS

PUMPTUBE MODEL	SEAL KITS*			GLAND SEAL KITS **		
	POLYURETHANE	TEFLON	POLYETHYLEN	POLYURETHAN	TEFLON	POLYETHYLEN
84900	84907	84912	84913	85311	85321	85327
84901	84911	84905	84906	85312	85322	85328
84902	84908	84914	84913	85313	85323	85329

\*Polyurethane Seal Kits contain all soft seals. Teflon and Polyethylene Seal Kits contain gland and piston u-cups only. \*\*Gland Seal Kits contain gland u-cup and o-ring only.

## ATTACHING AIRMOTOR TO PUMPTUBE

1. Tightly attach tie rods to the airmotor (use short threaded end of the tie rods).
2. Mount airmotor on top of the pumptube outlet and tightly connect Coupling Nut (237051) to airmotor piston rod.
3. Hand tighten tie rods to the pumptube with four nuts supplied with airmotor.
4. Slowly cycle the pump several times, using just enough air pressure to operate the pump without stalling.
5. Stop the pump on an "up" stroke and tighten the four nuts to securely fasten the airmotor to the pumptube.

## OPERATING PRECAUTIONS

- Use Lincoln replacement parts to assure compatible pressure rating.
- HEED ALL WARNINGS.
- Be sure material hoses and other components are able to withstand fluid pressures developed by this pump.
- Do not operate pump continuously at speeds in excess of 75 cycles per minute.
- Disconnect air line from pump airmotor when system sits idle for long periods of time.
- **SERVICING.** Before servicing or cleaning pump, or removing fluid hose or gun from a unit that has been used, be sure to disconnect air lines and carefully bleed pressure off of the system.



## WARNING

**PREVENT STATIC SPARKING.** If static sparking occurs, fire or explosion could result. Pump, dispensing valve, and containers must be grounded when handling inflammable fluids, such as petroleum products, paints, lacquers, etc. and wherever discharge of static electricity is a hazard.

- Check continuity (a good static wire connection) with an ohmmeter. Place one probe on one hose fitting and the other probe on other hose fitting, continuity or proper grounding through hose is good when a reading is obtained on the ohmmeter.
- **PREVENT FIRES.** When pumping, flushing or recirculating volatile solvents, the area must be adequately

ventilated.

- Keep solvents away from heat, sparks and open flames. Keep containers closed when not in use.



## CAUTION

**DO NOT allow pump to operate when out of material.**

## GLAND PACKING DESIGN\*

Many industrial type materials (sealants, adhesives, inks, etc.) display a tendency to dry-out and to build-up on the pump rod (plunger). These hard dried out materials cause the gland packing to wear out rapidly, resulting in leakage and ultimate pump failure. The second problem is the gland seal exposure to high pressure and in particular, to pressure fluctuation during pump operation (stroke changeover).

The new gland packing design, of Pile Driver III pumps addresses both problems:

©Externally, a special spring type Metal wiper (239950) scrapes built-up and dried material from the pump plunger before it is pulled through the gland packing on the down stroke. In order to help the metal wiper work longer and more efficiently, the lube well of the pump should be filled with a fluid compatible with the material being pumped.

**Do not fill the lube well to full capacity, as the reciprocating movement of the pump may draw fluid into the airmotor.**

Internally, a special Protection Sleeve (Item "D") with concentric grooves creates a labyrinth path which reduces the effects of internal pressure and stroke change over fluctuation on the gland seal. In addition, a second internal scraper limits gland seal exposure to the pumped material.

The combination of the metal scrapers and the protection sleeve results in longer gland seal life and prevents leakage.

## PUMP PRIMING

To begin operation, the pump has to be primed with the pumped material. The

Pile Driver III pump is a doubleacting (pumps material on "up"&"down" stroke) positive displacement reciprocating pump and as such intakes material only on the "up" stroke.

To prime pump, open output line (material valve) and slowly open air supply valve until pump starts. Allow pump to cycle very slowly until all air is pushed out of lines and material fills up pump and lines. Close output line (material shut-off valve) - pump should stall against pressure.

If pump fails to prime properly, open Bleeder Valve (84012) slightly to expel trapped air and at the sign of material coming out of the valve close it tightly.

**Note:** Pumps are factory tested with light oil and some of it is left in to protect pump parts during storage and transportation. To prevent contamination of material to be pumped, flush pump before using.

## OUTLET POSITION ADJUSTMENT

The position of the pump outlet may be adjusted by loosening the three set screws (246836) and rotating the pumptube outlet into the position desired. Retighten the set screws to 12 ft/lbs.

## SPECIFICATIONS

### Output per cycle:

<b>84900</b> - 22 cu. in.	(360 cc)
<b>84901</b> - 17 cu. in.	(278 cc)
<b>84902</b> - 12 cu. in.	(196 cc)

### Approximate cycles per gallon (liter):

<b>84900</b> - 11	(3)
<b>84901</b> - 14	(4)
<b>84902</b> - 20	(5)

### Output at 75 cycles/min:

<b>84900</b> - 7.1 gpm	(27.0 liters/min.)
<b>84901</b> - 5.5 gpm	(20.8 liters/min.)
<b>84902</b> - 3.9 gpm	(14.9 liters/min.)

**Pump stroke** - 6 in (152 mm)

**Max. recommended**

**speed (continuous)** - 75 cycles/min.

**Operating Temp Range** -

-30°F (-34°C) to +160°F (+71°C)

**Wetted part materials** - Steel, Bronze, Polyurethane, Nitrile

**Weight** - 50 Lbs.

\*U.S. Patent No. 4,976,192

## RETAIN THIS INFORMATION FOR FUTURE REFERENCE

When ordering replacement parts, list: Part Number, Description, Model Number and Series Letter. LINCOLN provides a Distributor Network that stocks equipment and replacement parts.