

Model Nos. 2324, 2345, 2351, 2366, 2373, 84904 PILE DRIVER III PUMP ASSEMBLY Series "B"

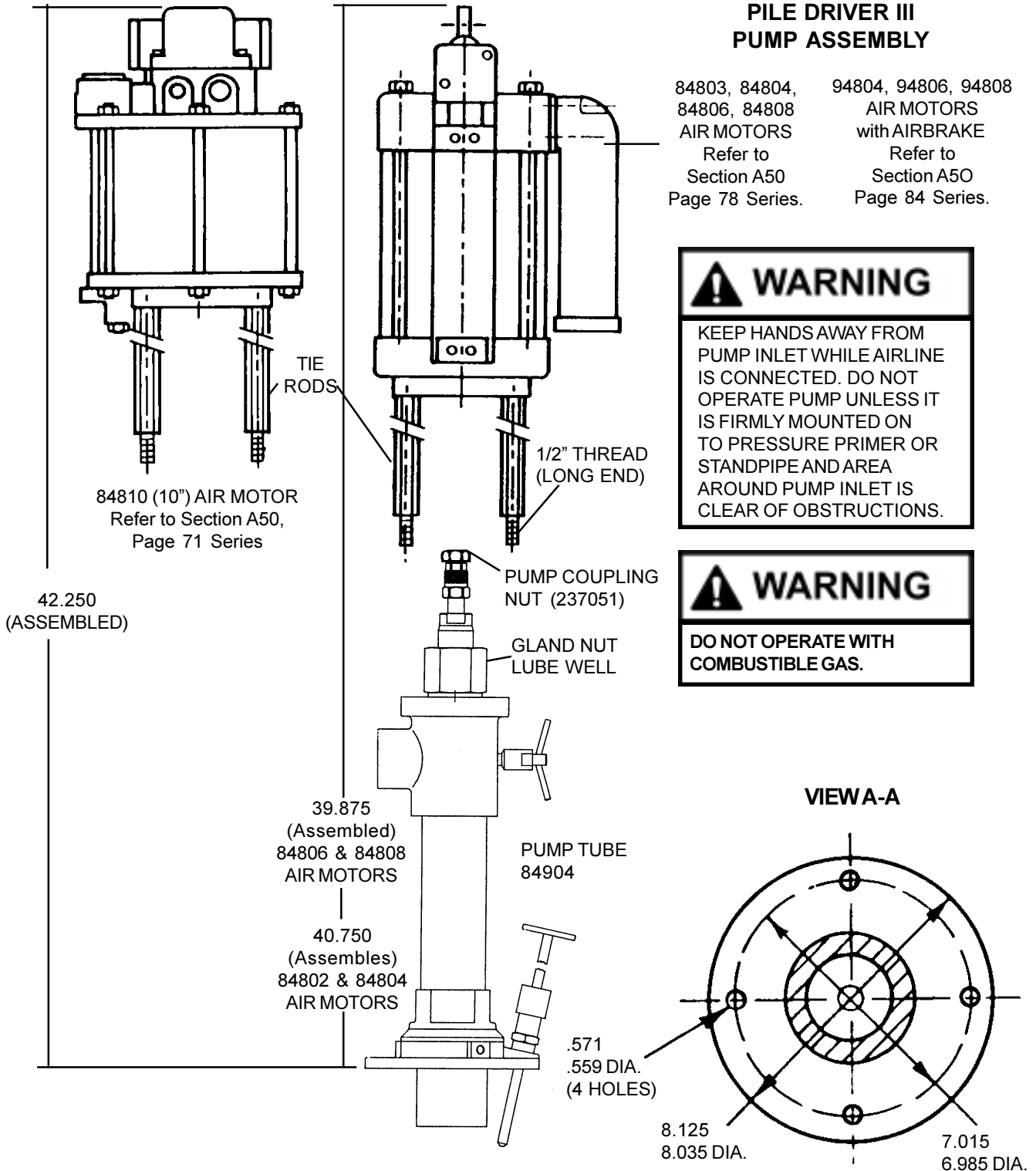

SPECIFICATIONS

Model	Ratio	Airmotor Size in. (mm)	Airmotor Model	Maximum Discharged Pressure PSIG (Bar)	Output Per Cycle cu. in. (cc)	Stroke Length in. (mm)	Minimum Air Supply Hose in. (mm)	Maximum Discharged Pressure PSIG (Bar)	Operating Temperature F° (C°)
2345	45:1	10(254)	84810	4,500(311)	18 (295)	6 (152)	3/4(20)	100 (7) 200 (14)	-30° to 160° (-34° to +71°)
2324	30:1	8(203)	84808	3,000 (207)			1/2(12)		
2351	18:01	6(152)	84806	1,800(124)			3/8(10)		
2366	8:01	4-1/4(108)	84804	1,600(110)					
2373	4:01	3(76)	84803	300 (21)					

NOTE: Pump should be installed upright for operation. Use Model 83727 stand pipe for bulk material dispensing. Locate pump as close to tank as possible and use a minimum of 3 inch (76 mm) ID. inlet hose or pipe.

ATTACHING AIRMOTOR TO PUMPTUBE

- Tightly attach tie rods to the airmotor (use short threaded end of the tie rods).
- Mount airmotor on top of the pumptube outlet and tightly connect Coupling Nut (237051) to airmotor piston rod.
- Hand tighten tie rods to the outlet with four nuts supplied with airmotor.
- Slowly cycle the pump several times, using just enough air pressure to operate the pump without stalling.
- Stop the pump on an "up" stroke and tighten the four nuts to securely fasten the airmotor to the pumptube.

OPERATING PRECAUTIONS

- * Use Lincoln replacement parts to assure compatible pressure rating.
- * **HEED ALL WARNINGS.** Be sure material hoses and other components are able to withstand fluid pressures developed by this pump.
- * Do not operate pump continuously at speeds in excess of 75 cycles per minute.
- * **SERVICING.** Before servicing or cleaning pump, or removing fluid hose or gun from a unit that has been used, be sure to disconnect air lines and carefully bleed pressure off the system.
- * Check continuity (a good static wire connection) with an ohmmeter. Place one probe on one hose fitting and the

other probe on other hose fitting, continuity or proper grounding through hose is good when a reading is obtained on the ohmmeter.

- * **PREVENT FIRES.** When pumping flushing or recirculating volatile solvents, the area must be adequately ventilated.
- * Keep solvents away from heat, sparks and open flames. Keep containers closed when not in use.



GLAND PACKING DESIGN*

Many industrial type materials (sealants, adhesives, inks, etc.) display a tendency to dry out and to build up on the pump rod (plunger). These hard dried out materials cause the gland packing to wear rapidly, resulting in leakage and ultimate pump failure. The second problem is the gland seal exposure to high pressure and in particular, to pressure fluctuation during pump operation (stroke change over).

The new gland packing design* of Pile Driver III pumps addresses both problems:

Externally, a special spring type Metal wiper scrapes built-up and dried material from the pump plunger before it is pulled through the gland packing on the down stroke. In order to help the metal wiper work longer and more efficiently, the lube well of the pump should be filled with a fluid compatible with the material being pumped.

Do not fill the lube well to full capacity, as the reciprocating movement of the pump may draw fluid into the airmotor.

Internally, a special Protection Sleeve (247253) with concentric grooves creates a labyrinth path which reduces the effects of internal pressure and stroke change over fluctuation on the gland seal. In addition, a second internal scraper limits gland seal exposure to the pumped material.

The combination of the metal scrapers and the protection sleeve results in longer gland seal life and prevents leakage.

PUMP PRIMING

To start operating, the pump has to be primed with pumped materials. The Pile Driver III pump is double acting (pumps material on up" & down" stroke) positive displacement reciprocating pump and as such intakes material only on "up" stroke.

To prime pump, open output line (material valve) and slowly open air supply valve until pump starts. Allow pump to cycle very slowly until all air is pushed out of lines and material fills out pump and lines. Close output line (material valve) - pump should stall against pressure.

If pump fails to prime properly, open Bleeder Valve (8401 2) slightly to expel trapped air and at the sign of material coming out of the valve, close it tightly.

NOTE: Pumps are factory tested with light oil and some of it is left in to protect pump parts during storage and transportation. To prevent contamination of material to be pumped, flush pump before using.

OUTLET POSITION ADJUSTMENT

The position of the pump outlet may be adjusted by loosening the three set screws (246836) and rotating the pumptube outlet into the position desired. Retighten the set screw to 12 ft/lbs.

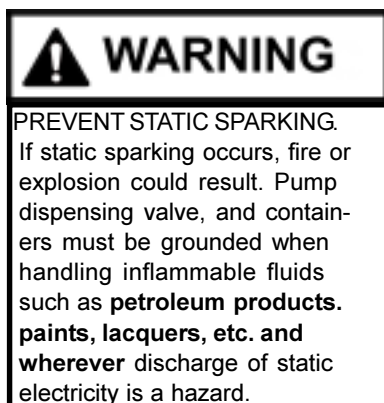

PILE DRIVER III PUMP ASSEMBLY 84904

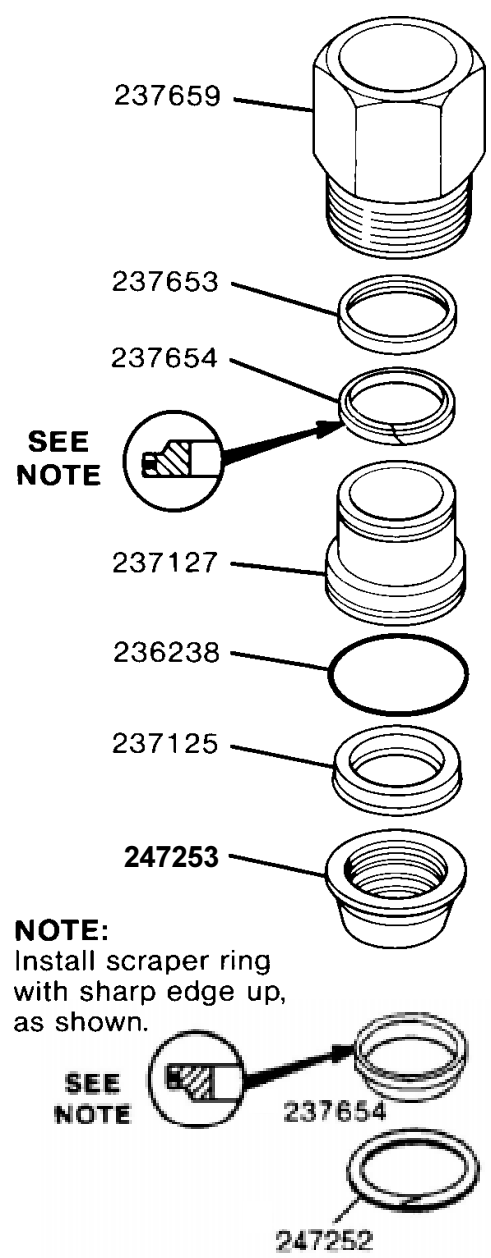

NOTE:
Install scraper ring
with sharp edge up,
as shown.

PUMPTUBE SERVICE KITS

	Polyurethane	Teflon	Polyethylene
Seal Kit	84909	84916	84917
Gland Seal kit	85314	85324	85330

Polyurethane Seal Kit contains all soft seals.
Teflon and Polyethylene Seal Kits contain gland and piston u-cups only.
Gland Seal kits contain gland u-cup and O-ring only.

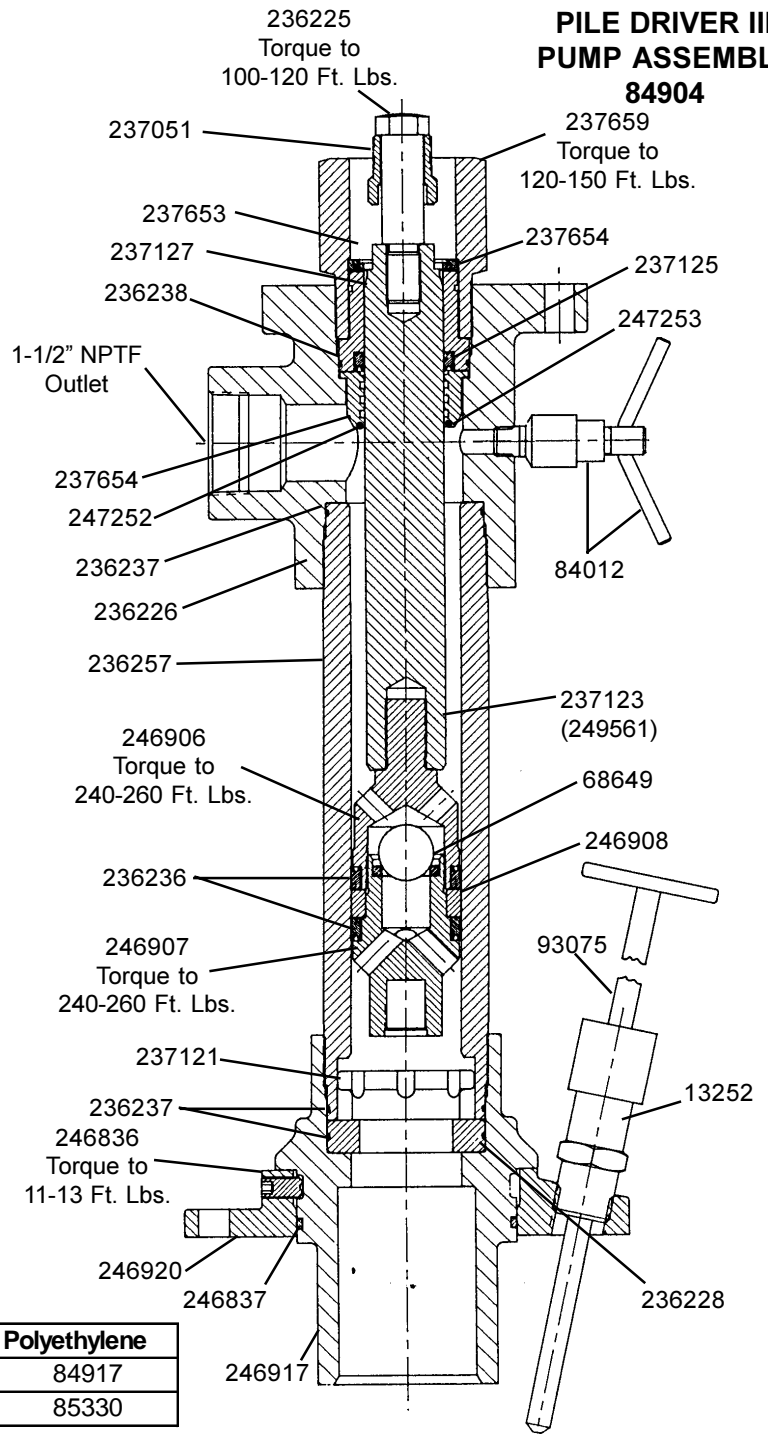

SERVICE PARTS

PART	QTY.	DESCRIPTION	PART	QTY.	DESCRIPTION	PART	QTY.	DESCRIPTION
13252	1	Connector (1-1/8" hex)	236266	1	Outlet body	246837	1	O-Ring (Nitrile)
68649	1	Check ball	237051	1	Coupling nut (1-1/8" hex)	246906	1	Piston nut (1-5/8" Flats)
84012	1	Bleeder valve (3/4" flats)	237121	1	Check	246907	1	Piston body (1-1/8" flats)
93075	1	Priming plug	237123	1	Plunger (1-1/8" flats) ϕ 1.4369/1.4359 [©]	246908	1	Piston collar
236225	1	Bolt Connector (7/8" hex)	237125	1	U-Cup (polyurethane)	246917	1	Inlet bushing (3-1/2" flats)
236228	1	Check Seat	237127	1	Bushing	246920	1	Mounting flange
236236	2	U-Cup (polyurethane)	237653	1	Spacer	247252	1	Retaining ring
236237	3	O-Ring (polyurethane)	237654	2	Wiper	247253	1	Sleeve (Stamped "M")
236238	1	O-Ring (polyurethane)	237659	1	Gland nut (2-5/8" hex)			
236257	1	Pump tube	246836	3	Set Screw (3/16" hex socket)			

© Indicates change

TROUBLESHOOTING

Problem	Possible Cause	Solution
Pump does not operate.	Restricted or inadequate air supply.	Check air supply pressure and air hose diameter (see specifications for minimum air supply hose diameter).
	Obstructed material output.	Check output line for restrictions.
Erratic or accelerated operation.	Pump is not primed.	Prime pump (see "pump priming instructions").
	Insufficient material supply.	Refill material supply.
	Material is too heavy for priming.	Lower output with material valve. Increase pressure to pressure primer (if in use). Check for inlet restrictions.
Pump operates on "down" stroke only (missing "up" stroke).	Worn or damaged piston packing (236236) or piston check (68649 & 246907).	Check and replace if needed.
Pump operates on "up" stroke only (missing "down" stroke).	Worn or damaged inlet check (237121).	Check and replace if needed.
	Insufficient material supply, pump is not intaking enough material to dispense on both strokes.	Check inlet for restrictions, lower output with material valve.
Pump is operating but not dispensing material.	Inlet check (237121) is not seating or damaged.	Check and replace if needed.

DISASSEMBLY PROCEDURE

Tools Required	(Used on Part #)	Tools Required	(Used on Part #)
3/16" hex key	(246836)	1-5/8" wrench	(246906)
314 wrench	(84012)	2-5/8" wrench	(237659)
7/8" wrench	(236225)	3-1/2" wrench	(246917)
1-1/8" wrench	(13252, 237051, 237123 & 246907)	3" dia. strap wrench	(236257)
		Two screwdrivers	(237127 & 247252)

Procedure

1. Remove Set Screws 246836 from Mounting Flange 246920.
2. Remove Mounting Flange 246920 from Inlet Bushing 246917.
 - a. Remove priming Plug 93075 from Connector 13252.
 - b. Remove Connector 13252 from Mounting Flange 246920.
3. Remove Inlet Bushing 246917 from pump Tube 236257.
 - a. Remove 0-ring 246837 from Inlet Bushing 246917.
 - b. Remove Check Seat 246228 from Inlet Bushing 246917.
 - c. Remove 0-ring 236237 from Check Seat 236228.
4. Remove Check 237121 from Pump Tube 236257.
5. Remove Bolt Connector 236225 from Plunger 237123.
6. Remove piston and plunger assembly from bottom of Pump Tube 236257.
 - a. Remove piston assembly from plunger 237123.
 - b. Remove Piston Nut 246906 and Check Ball 68649 from Piston Body 246907.
 - c. Remove U-cup 236236 from Piston Nut 246906.
 - d. Remove Piston Collar 246908 from Outlet Body 236266.
7. Remove Pump Tube 236257 from Outlet Body 236266.
 - a. Remove 0-rings 236237 from Pump Tube 236257.
8. Remove Bleeder Valve 84012 from Outlet Body 236266.
9. Remove Gland Nut 237659 from Outlet Body 236266.
 - a. Remove Wiper 237654 and Spacer 237653 from Gland Nut 237659.
10. Remove Bushing 237127 from Outlet Body 236266.
 - a. Remove 0-ring 236238 and U-cup 237125 from Bushing 237127.
11. Remove Sleeve 247253, Scraper 237654 and Retaining Ring 247252.
12. To reassemble pump, reverse disassembly procedure. (Refer to illustration for torque specifications.)

RETAIN THIS INFORMATION FOR FUTURE REFERENCE

When ordering replacement parts, list: Part Number, Description, Model Number and Series Letter, LINCOLN provides a Distributor Network that stocks equipment and replacement parts.