

© Indicates Change

## SPECIFICATIONS

Model	Ratio	Airmotor Size in. (mm)	Airmotor Model	Maximum Discharge Pressure PSIG (Bar)	Output Per Cycle cu. in. (cc)	Stroke Length in. (mm)	Minimum Air Supply Hose in. (mm)	Maximum Operating Air Pressure PSIG (Bar)	Operating Temperature F° (C°)
2319	10:1	10 (254)	84810	1,000 (69)	90 (1475)	6 (152)	3/4 (20)	100 (7)	30° to 200° (-34° to +93°)
2328	6:1	8 (203)	84808	600 (41)					
2356	3:1	6 (152)	84806	300 (21)					
2370	1.5:1	4-1/4 (108)	84804	300 (21)					
2341	1:1	3 (76)	84803	200 (14)					
							1/2 (12)	200 (14)	

**Note:** Pump should be installed upright for operation. Use Model 83727 stand pipe for bulk material dispensing. Locate pump as close to tank as possible and use a minimum 3 inch (76mm) I.D. inlet hose or pipe.

### ATTACHING AIRMOTOR TO PUMPTUBE\*

1. Tightly attach tie rods to the airmotor (use short threaded end of the tie rods).
2. Mount airmotor on top of the pump-tube outlet and tightly connect Coupling Nut (237051) to airmotor piston rod.
3. Hand tighten tie rods to the outlet with four nuts supplied with airmotor.
4. Slowly cycle the pump several times, using just enough air pressure to operate the pump without stalling.
5. Stop the pump on an "up" stroke and tighten the four nuts to securely fasten the airmotor to the pumptube.

### OPERATING PRECAUTIONS

- Use Lincoln replacement parts to assure compatible pressure rating.
- HEED ALL WARNINGS.
- Be sure material hoses and other components are able to withstand fluid pressures developed by this pump.
- Do not operate pump continuously at speeds in excess of 75 cycles per minute.
- Disconnect air line from pump air motor when system sits idle for long periods of time.
- **SERVICING.** Before servicing or cleaning pump, or removing fluid hose or gun from a unit that has been used, be sure to disconnect air lines and carefully bleed pressure off of the system.



### WARNING

**PREVENT STATIC SPARKING.** If static sparking occurs, fire or explosion could result. Pump, dispensing valve, and containers must be grounded when handling inflammable fluids such as petroleum products, paints, lacquers, etc. and wherever discharge of static electricity is hazard.

- Check continuity (a good static wire connection) with an ohmmeter. Place one probe on one hose fitting and the other probe on other hose fitting, continuity or proper grounding through hose is good when a reading is obtained on the ohmmeter.
- **PREVENT FIRES.** When pumping, flushing or recirculating volatile solvents, the area must be adequately ventilated.
- Keep solvents away from heat, sparks and open flames. Keep containers closed when not in use.



### CAUTION

**DO NOT allow pump to operate when out of material.**

### GLAND PACKING DESIGN\*

Many industrial type materials (sealants, adhesives, inks, etc.) display a tendency to dry-out and to build-up on the pump rod (plunger). These hard dried out materials cause the gland packing to wear out rapidly, resulting in leakage and ultimate pump failure. The second problem is the gland seal exposure to high pressure and in particular, to pressure fluctuation during pump operation (stroke changeover).

The new gland packing design\* of Pile Driver III pumps addresses both problems:

A special spring type Metal Wiper (241603), scrapes built up and dried out material from the pump rod (plunger). In order to help the metal wiper to work longer and more efficiently, the lube well of the pump should be filled with a fluid compatible with pumped material.

**Do not fill lube well to full capacity, as the reciprocating movement of the pump may draw fluid into the airmotor.**

\* Patent pending.

Secondly a special Protection Sleeve (239917) with concentric grooves creates a labyrinth path and reduces internal operational pressure and at the same time pressure fluctuation during a stroke changeover, limits gland seal exposure to pumped material.

A combination of the metal scraper and protection sleeve prolongs gland seal life and prevents leakage.

### PUMP PRIMING

To start operating, the pump has to be primed with pumping material. The Pile Driver III pump is double acting (pumps material on "up" & "down" stroke) positive displacement reciprocating pump and as such intakes material only on "up" stroke.

To prime pump-open output line (material valve) and slowly open air supply valve until pump starts. Allow pump to cycle very slowly until all air is pushed out of lines and material fills out pump and lines. Close output line (material valve) - pump should stall against pressure.

If pump fails to prime properly open Bleeder Valve (84012) slightly to expel trapped air and at the sign of material coming out of the valve close it tightly.

**Note:** Pumps are factory tested with light oil and some of it is left in, to protect pump parts during storage and transportation. To prevent contamination of material to be pumped, flush pump before using.

# PILE DRIVER III PUMPTUBE ASSEMBLY 84923

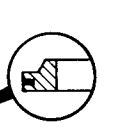
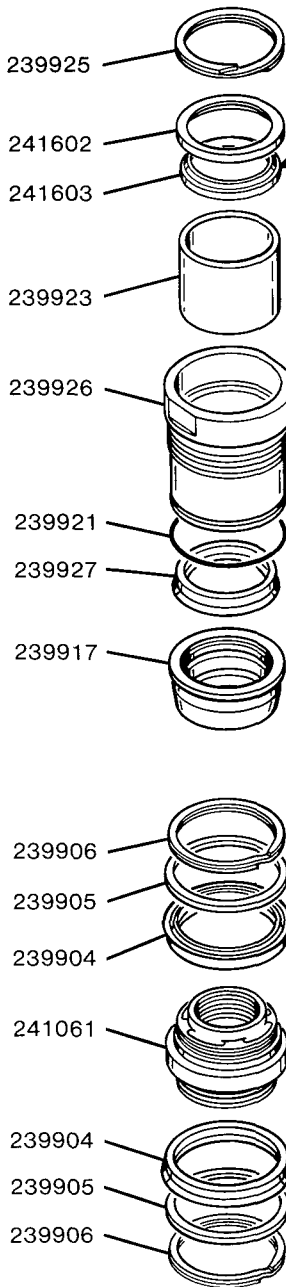

© Install scraper ring with sharp edge up, as shown.

236225 Torque to 100-120 Ft. Lbs. ©

© Indicates Change

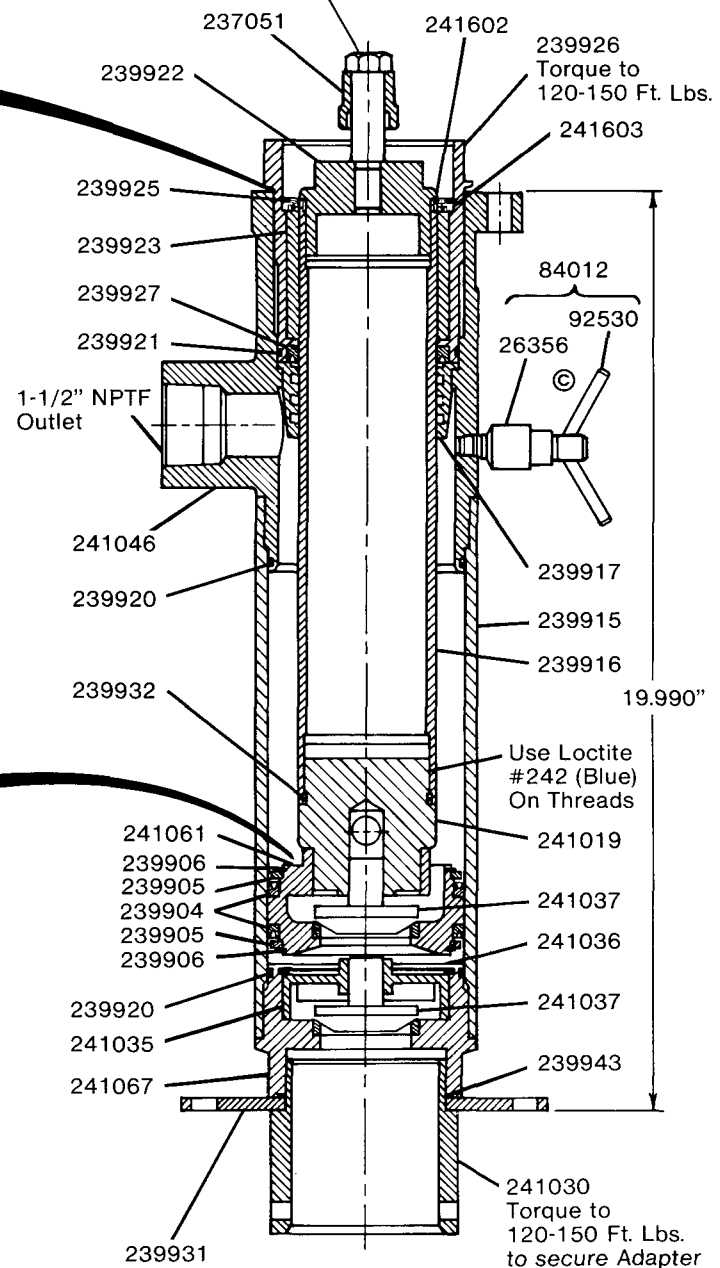

### PUMPTUBE SERVICE KITS

(Refer to Section K4, Page 46 Series)

Standard Polyurethane Packing Kit	84924
Teflon Packing Kit	84925
UHMW Polyethylene Packing Kit	84926

### SERVICE PARTS

Part	Qty.	Description	Part	Qty.	Description	Part	Qty.	Description
26356	1	Valve body	*239920	2	O-ring (polyurethane)	241019	1	Piston
84012	1	Bleeder valve	*239921	1	O-ring (polyurethane)	241030	1	Tube
92530	1	Valve stem & pin	239922	1	End plug	241035	1	Check guide
236225	1	Bolt connector	*239923	1	Bushing	*241036	1	Retaining ring
237051	1	Nut	*239925	1	Retaining ring	241037	2	Check
*239904	2	U-cup (polyurethane)	239926	1	Retainer	241046	1	Outlet body
239905	2	Washer	*239927	1	U-cup (polyurethane)	241061	1	Piston
*239906	2	Retaining ring	239931	1	Adapter	241067	1	Body & check assembly
239915	1	Tube body	*239932	1	O-ring (polyurethane)	*241602	1	Spacer
239916	1	Piston tube	*239943	1	O-ring (polyurethane)	*241603	1	Wiper
239917	1	Sleeve						

\* Included in 241682 Repair Kit

## TROUBLESHOOTING

Problem	Possible Cause	Solution
Pump is not working.	Restricted or inadequate air supply.	Check air supply pressure and air hose diameter (see specification for minimum air supply hose diameter).
	Obstructed material output.	Check output line for restrictions.
Erratic or accelerated operation.	Pump is not primed.	Prime pump (see "pump priming" instructions).
	Insufficient material supply.	Refill material supply.
	Material is too heavy for priming.	Lower output with material valve. Increase pressure to pressure primer (if in use). Check for inlet restrictions.
Pump operates on "down" stroke only (missing "up" stroke).	Worn or damaged piston packing (239904) or piston check (241037 & 241049).	Check and replace if needed.
Pump operates on "up" stroke only (missing "down" stroke).	Worn or damaged inlet check (241037).	Check and replace if needed.
	Insufficient material supply, pump is not intaking enough material to dispense on both strokes.	Check inlet for restrictions. Lower output with material valve.
Pump is operating but not dispensing material.	Inlet check (241037) is not seating or damaged.	Check and replace if needed.

**RETAIN THIS INFORMATION FOR FUTURE REFERENCE**

When ordering replacement parts, list: Part Number, Description, Model Number and Series Letter.  
LINCOLN provides a Distributor Network that stocks equipment and replacement parts.