

PILE DRIVER III
PUMP ASSEMBLY

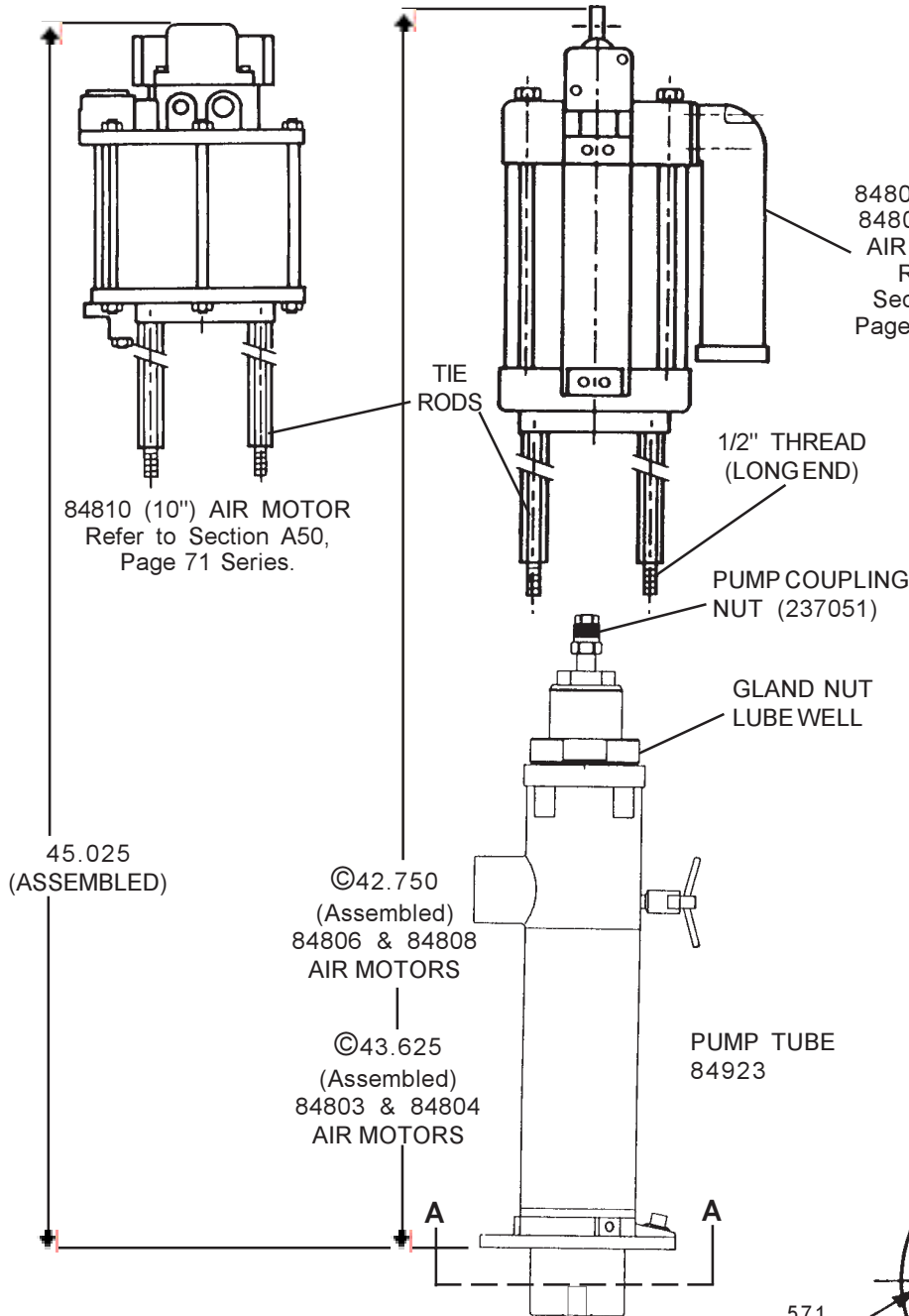

WARNING

KEEP HANDS AWAY FROM PUMP INLET WHILE AIRLINE IS CONNECTED. DO NOT OPERATE PUMP UNLESS IT IS FIRMLY MOUNTED ONTO PRESSURE PRIMER OR STANDPIPE AND AREA AROUND PUMP INLET IS CLEAR OF OBSTRUCTIONS.

WARNING

DO NOT OPERATE WITH COMBUSTIBLE GAS

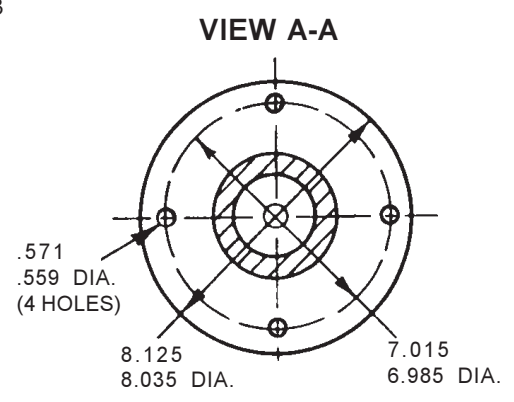

Model	Ratio	Airmotor Size in. [mm]	Airmotor Model	Maximum Discharge Pressure PSIG [Bar]	Output Per Cycle cu. in [cc]	Stroke Length in. [mm]	Minimum Air Supply Hose in. [mm]	Maximum Operating Air Pressure PSIG [Bar]	Operating Temperature F° [C°]
2319	10:1	10 [254]	84810	1,000 [69]	90 [1475]	6 [152]	3/4 [20]	100 [7]	-30° to 160° [-34° to +71°]
2328	6:1	8 [203]	84808	600 [41]					
2356	3:1	6 [152]	84806	300 [21]					
2370	1.5:1	4-1/4 [108]	84804	300 [21]			1/2 [12]	200 [14]	
2341	1:1	3 [76]	84803	200 [14]					

NOTE: Pump should be installed upright for operation. Use Model 83727 stand pipe for bulk material dispensing. Locate pump as close to tank as possible and use a minimum 3 inch (76mm) I.D. inlet hose or pipe.

ATTACHING AIRMOTOR TO PUMPTUBE

1. Tightly attach tie rods to the airmotor (use short threaded end of the tie rods).
2. Mount airmotor on top of the pumptube outlet and tightly connect Coupling Nut (237051) to airmotor piston rod.
3. Hand tighten tie rods to the pumptube with four nuts supplied with airmotor.
4. Slowly cycle the pump several times, using just enough air pressure to operate the pump without stalling.
5. Stop the pump on an "up" stroke and tighten the four nuts to securely fasten the airmotor to the pumptube.

OPERATING PRECAUTIONS

- Use Lincoln replacement parts to assure compatible pressure rating.
- HEED ALL WARNINGS.
- Be sure material hoses and other components are able to withstand fluid pressures developed by this pump.
- Do not operate pump continuously at speeds in excess of 75 cycles per minute.
- Disconnect air line from pump airmotor when system sits idle for long periods of time.
- SERVICING. Before servicing or cleaning pump, or removing fluid hose or gun from a unit that has been used, be sure to disconnect air lines and carefully bleed pressure off of the system.
- Check continuity (a good static wire connection) with an ohmmeter. Place



WARNING

PREVENT STATIC SPARKING. If static sparking occurs, fire or explosion could result. Pump, dispensing valve, and containers must be grounded when handling inflammable fluids, such as petroleum products, paints, lacquers, etc. and wherever discharge of static electricity is a hazard.

one probe on one hose fitting and the other probe on other hose fitting, continuity or proper grounding through hose is good when a reading is obtained on the ohmmeter.

- PREVENT FIRES. When pumping, flushing or recirculating volatile solvents, the area must be adequately ventilated.
- Keep solvents away from heat, sparks and open flames. Keep containers closed when not in use.



CAUTION

DO NOT allow pump to operate when out of material.

GLAND PACKING DESIGN*

Many industrial type materials (sealants, adhesives, inks, etc.) display a tendency to dry-out and to build-up on the pump rod (plunger). These hard dried out materials cause the gland packing to wear out rapidly, resulting in leakage and ultimate pump failure. The second problem is the gland seal exposure to high pressure and in particular, to pressure fluctuation during pump operation (stroke changeover).

The new gland packing design* of Pile Driver III pumps addresses both problems:

©Externally, a special spring type Metal wiper (241603) scrapes built-up and dried material from the pump plunger before it is pulled through the gland packing on the down stroke. In order to help the metal wiper work longer and more efficiently, the lube well of the pump should be filled with a fluid compatible with the material being pumped.

Do not fill the lube well to full capacity, as the reciprocating movement of the pump may draw fluid into the airmotor.

Internally, a special Protection Sleeve (247272) with concentric grooves creates a labyrinth path which reduces the effects of internal pressure and stroke change over fluctuation on the gland seal. In addition, a second internal scraper limits gland seal exposure to the pumped material.

The combination of the metal scrapers and the protection sleeve results in longer gland seal life and prevents leakage.

PUMP PRIMING

To begin operation, the pump has to be primed with the pumped material. The Pile Driver III pump is a double acting (pumps material on "up"&"down" stroke) positive displacement reciprocating pump and as such intakes material only on the "up" stroke.

To prime pump, open output line (material valve) and slowly open air supply valve until pump starts. Allow pump to cycle very slowly until all air is pushed out of lines and material fills up pump and lines. Close output line (material shut-off valve) - pump should stall against pressure.

If pump fails to prime properly, open Bleeder Valve (84012) slightly to expel trapped air and at the sign of material coming out of the valve close it tightly.

Note: Pumps are factory tested with light oil and some of it is left in to protect pump parts during storage and transportation. To prevent contamination of material to be pumped, flush pump before using.

OUTLET POSITION ADJUSTMENT

The position of the pump outlet may be adjusted by loosening the three set screws (246836) and rotating the pumptube outlet into the position desired. Retighten the set screws to 12 ft/lbs.

*U.S. Patent No. 4,976,192

© Indicates Change

PILE DRIVER III PUMP ASSEMBLY 84923

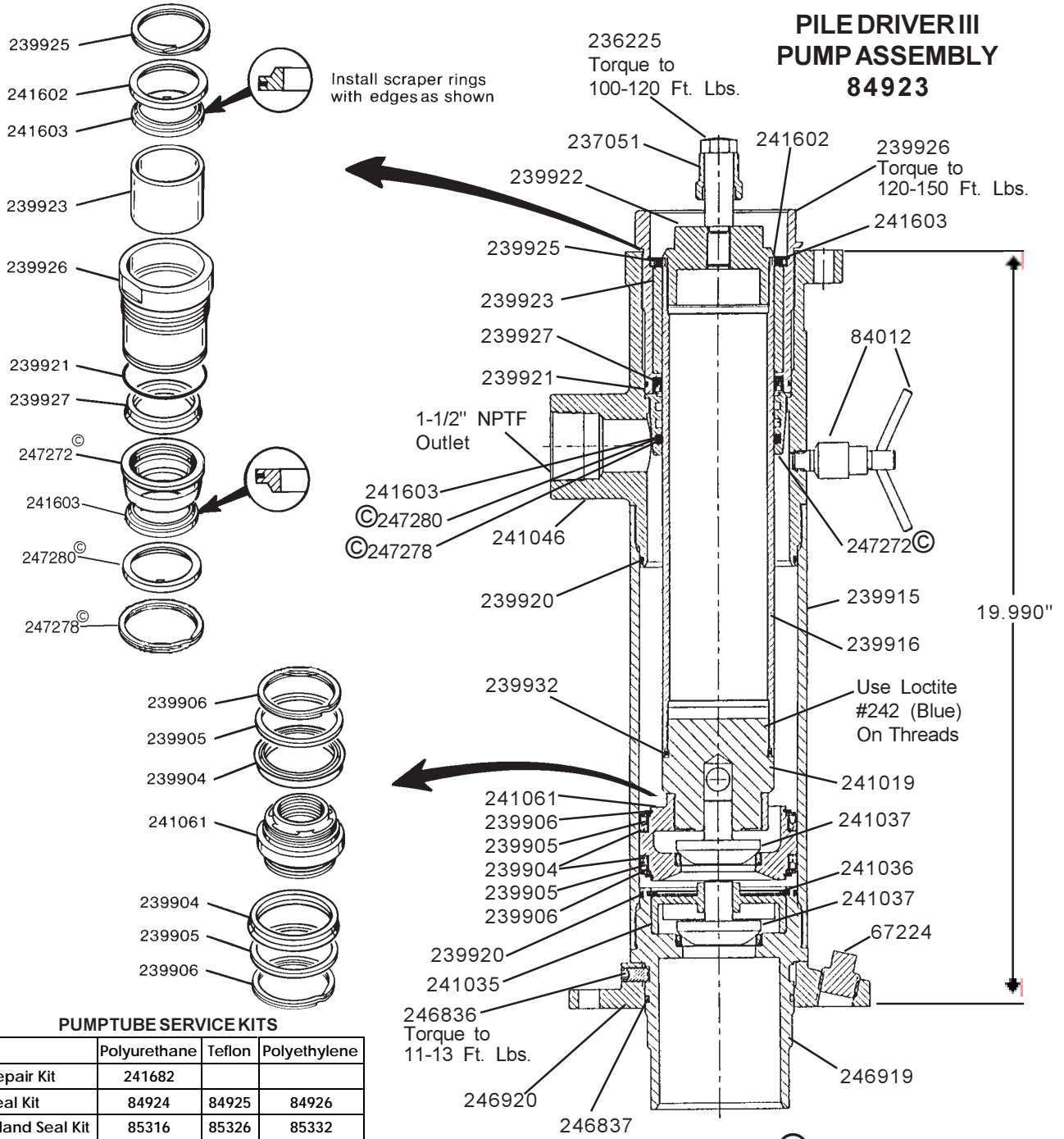

PUMPTUBE SERVICE KITS

	Polyurethane	Teflon	Polyethylene
Repair Kit	241682		
Seal Kit	84924	84925	84926
Gland Seal Kit	85316	85326	85332

Repair Kit contains all parts needed for complete pumptube rebuild.
 Polyurethane Seal Kit contains all soft seals.
 Teflon and Polyethylene Seal Kits contain gland and piston u-cups only.
 Gland Seal kits contain gland u-cup and o-ring only.

© Indicates Change

SERVICE PARTS

PART	QTY.	DESCRIPTION	PART	QTY.	DESCRIPTION	PART	QTY.	DESCRIPTION
67224	1	Pipe plug (5/8" square)	239922	1	End Plug (2" flats)	241061	1	Piston
84012	1	Bleeder Valve (3/4" flats)	239923	1	Bushing	^241602	1	Spacer
236225	1	Bolt Connector (7/8" hex.)	^239925	1	Retaining Ring	^241603	2	Wiper
237051	1	Coupling Nut (1-1/8" hex.)	239926	1	Gland Nut (4-1/8" flats)	246836	3	Set Screw (3/16" hex socket)
^*239904	2	U-cup (polyurethane)	#^*239927	1	U-cup (polyurethane)	^*246837	1	O-ring (nitrile)
239905	2	Washer	^*239932	1	O-ring (polyurethane)	246919	1	Inlet Bushing (3-3/4" flats)
^239906	2	Retaining Ring	241019	1	Piston	246920	1	Mounting Flange
239915	1	Pump Tube	241035	1	Check Guide	^247278	1	Retaining Ring
239916	1	Piston Tube	^241036	1	Retaining Ring	247272	1	Sleeve
^*239920	2	O-ring (polyurethane)	241037	2	Check	^247280	1	washer
#^*239921	1	O-ring (polyurethane)	241046	1	Outlet Body			

^Included in 241682 Repair Kit *Included in 84924 Seal Kit #Included in 85316 Gland Seal Kit

TROUBLESHOOTING

Problem	Possible Cause	Solution
Pump does not operate.	Restricted or inadequate air supply.	Check air supply pressure and air hose diameter (see specifications for minimum air supply hose diameter).
	Obstructed material output.	Check output line for restrictions.
Erratic or accelerated operation.	Pump is not primed.	Prime pump (see "pump priming instructions").
	Insufficient material supply.	Refill material supply.
	Material is too heavy for priming.	Lower output with material valve. Increase pressure to pressure primer (if in use). Check for inlet restrictions.
Pump operates on "down" stroke only (missing "up" stroke).	Worn or damaged piston packing (239904) or piston check (241037 & 241061).	Check and replace if needed.
Pump operates on "up" stroke only (missing "down" stroke).	Worn or damaged inlet check (241037).	Check and replace if needed.
	Insufficient material supply, pump is not intaking enough material to dispense on both strokes.	Check inlet for restrictions. lower output with material valve.
Pump is operating but not dispensing material.	Inlet check (241037) is not seating or damaged.	Check and replace if needed.

DISASSEMBLY PROCEDURE

<p>Tools Required</p> <p>3/16" hex key (246836) 5/8" wrench (67224) 3/4" wrench (84012) 7/8" wrench (236225) 1-1/8" wrench (237051) 2" wrench (239922) 3-3/4" wrench (246919) 4-1/8" wrench (239926) 4-3/4" dia. strap wrench(239915) Screwdriver(239906, 239925, 241036 & 247278)</p> <p>Procedure</p> <ol style="list-style-type: none"> 1. Remove Set Screws 246836 from Mounting Flange 246920. 2. Remove Mounting Flange 246920 from Inlet Bushing 246919. <ol style="list-style-type: none"> a. Remove Pipe Plug 67224 from Mounting Flange 246920. 3. Remove Inlet Bushing 246919 from Pump Tube 239915. 	<ol style="list-style-type: none"> a. Remove O-ring 246837 from Inlet Bushing 246919. b. Remove O-ring 239920 from Inlet Bushing 246919. c. Remove Retaining Ring 241036 from Inlet Bushing 246919. d. Remove Check Guide 241035 and Check 241037 from Inlet Bushing 246919. 4. Remove Bolt Connector 236225 from End Plug 239922. <ol style="list-style-type: none"> a. Slide Coupling Nut 237051 off Bolt Connector 236225. 5. Remove piston and plunger assembly from bottom of Pump Tube 239915. <ol style="list-style-type: none"> a. Remove piston assembly from Piston 241019. b. Remove Check 241037 from Piston 241019. c. Remove Retaining Rings 239906 from Piston 241061. d. Remove Washers 239905 and U-cups 239904 from Piston 241061. e. Remove Piston 241019 from Piston Tube 239916. 	<ol style="list-style-type: none"> f. Remove O-ring 239932 from Piston 241019. g. Remove End Plug 239922 from Piston Tube 239916. 6. Remove Pump Tube 239915 from Outlet Body 241046. 7. Remove O-ring 239920 from Outlet Body 241046. 8. Remove Bleeder Valve 84012 from Outlet Body 241046. 9. Remove gland nut assembly from Outlet Body 241046. <ol style="list-style-type: none"> a. Remove O-ring 239921 and U-cup 239927 from Gland Nut 239926. b. Remove Retaining Ring 239925 from Gland Nut 239926. c. Remove Spacer 241602, Wiper 241603 and Bushing 239923 from Gland Nut 239926. 10. Remove Sleeve 247272, Scraper 241603, Washer 247280 and Retaining Ring 247278, from Outlet Body 241046. 11. To re-assemble pump, reverse disassembly procedure. (Refer to illustration for torque specifications.)
--	---	--

RETAIN THIS INFORMATION FOR FUTURE REFERENCE

When ordering replacement parts, list: Part Number, Description, Model Number and Series Letter.
 LINCOLN provides a Distributor Network that stocks equipment and replacement parts.