

SPECIFICATIONS

Model	Ratio	Airmotor Size in. (mm)	Airmotor Model	Maximum Discharge Pressure PSIG (Bar)	Output Per Cycle cu. in. (cc)	Stroke Length in. (mm)	Minimum Air Supply Hose in. (mm)	Maximum Operating Air Pressure PSIG (Bar)	Operating Temperature F° (C°)
2321	20:1	10 (254)	84810	2,000 (38)	44 (721)	6 (152)	3/4 (20)	100 (7)	-30° to 160° (-34° to +71°)
2327	13:1	8 (203)	84808	1,300 (90)					
2354	7:1	6 (152)	84806	700 (48)					
2369	3:1	4 - 1/4 (108)	84804	600 (41)					
2329	1.5:1	3 (76)	84803	300 (21)			1/2 (12)	200 (14)	

NOTE: Pump should be installed upright for operation. Use Model 83727 stand pipe for bulk material dispensing. Locate pump as close to tank as possible and use a minimum of 3 inch (76 mm) I.D. inlet hose or pipe.

ATTACHING AIRMOTOR TO PUMPTUBE*

1. Tightly attach tie rods to the airmotor (use short threaded end of the tie rods).
2. Mount airmotor on top of the pumptube outlet and tightly connect Coupling Nut (237051) to airmotor piston rod.
3. Hand tighten tie rods to the outlet with four nuts supplied with airmotor.
4. Slowly cycle the pump several times, using just enough air pressure to operate the pump without stalling.
5. Stop the pump on an "up" stroke and tighten the four nuts to securely fasten the airmotor to the pumptube.

OPERATING PRECAUTIONS

- * Use Lincoln replacement parts to assure compatible pressure rating.
- * **HEED ALL WARNINGS.**
- * Be sure material hoses and other components are able to withstand fluid pressures developed by this pump.
- * Do not operate pump continuously at speeds in excess of 75 cycles per minute.
- * **SERVICING.** Before servicing or cleaning pump, or removing fluid hose or gun from a unit that has been used, be sure to disconnect air lines and carefully bleed pressure off the system.

- * Check continuity (a good static wire connection) with an ohmmeter. Place one probe on one hose fitting and the other probe on other hose fitting, continuity or proper grounding through hose is good when a reading is obtained on the ohmmeter.
- * **PREVENT FIRES.** When pumping flushing or recirculating volatile solvents, the area must be adequately ventilated.
- * Keep solvents away from heat, sparks and open flames. Keep containers closed when not in use.



GLAND PACKING DESIGN*

Many industrial type materials (sealants, adhesives, inks, etc.) display a tendency to dry out and to build up on the pump rod (plunger). These hard dried out materials cause the gland packing to wear rapidly, resulting in leakage and ultimate pump failure. The second problem is the gland seal exposure to high pressure and in particular, to pressure fluctuation during pump operation (stroke change over).

The new gland packing design* of Pile Driver III pumps addresses both problems:

©Externally, a special spring type Metal wiper (239950) scrapes built-up and dried material from the pump plunger before it is pulled through the gland packing on the down stroke. In order to help the metal wiper work longer and more efficiently, the lube well of the pump should be filled with a fluid compatible with the material being pumped.

Do not fill the lube well to full capacity, as the reciprocating movement of the pump may draw fluid into the airmotor.

Internally, a special Protection Sleeve (247271)© with concentric grooves creates a labyrinth path which reduces the effects of internal pressure and stroke change over fluctuation on the gland seal. In addition, a second internal scraper limits gland seal exposure to the pumped material.

The combination of the metal scrapers and the protection sleeve results in longer gland seal life and prevents leakage.

PUMP PRIMING

To start operating, the pump has to be primed with pumped materials. The Pile Driver III pump is double acting (pumps material on "up" & "down" stroke) positive displacement reciprocating pump and as such intakes material only on "up" stroke.

To prime pump, open output line (material valve) and slowly open air supply valve until pump starts. Allow pump to cycle very slowly until all air is pushed out of lines and material fills out pump and lines. Close output line (material valve) - pump should stall against pressure.

If pump fails to prime properly, open Bleeder Valve (84012) slightly to expel trapped air and at the sign of material coming out of the valve, close it tightly.

NOTE: Pumps are factory tested with light oil and some of it is left in to protect pump parts during storage and transportation. To prevent contamination of material to be pumped, flush pump before using.

OUTLET POSITION ADJUSTMENT

The position of the pump outlet may be adjusted by loosening the three set screws (246836) and rotating the pumptube outlet into the position desired. Retighten the set screw to 12 ft/lbs.

*U.S. Patent No. 4,976,192

© Indicates change

PREVENT STATIC SPARKING.
If static sparking occurs, fire or explosion could result. Pump dispensing valve, and containers must be grounded when handling inflammable fluids such as petroleum products, paints, lacquers, etc. and wherever discharge of static electricity is a hazard.

PILE DRIVER III PUMP ASSEMBLY 84922

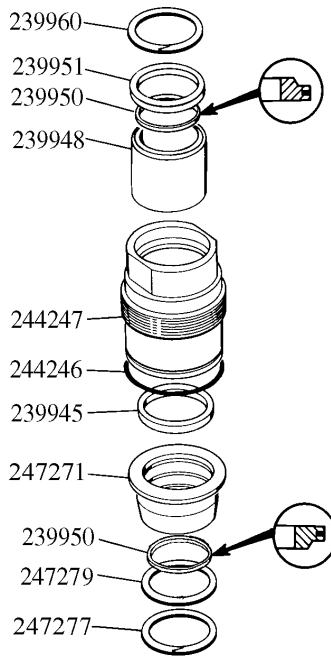

Install scraper rings with sharp edge up, as shown.

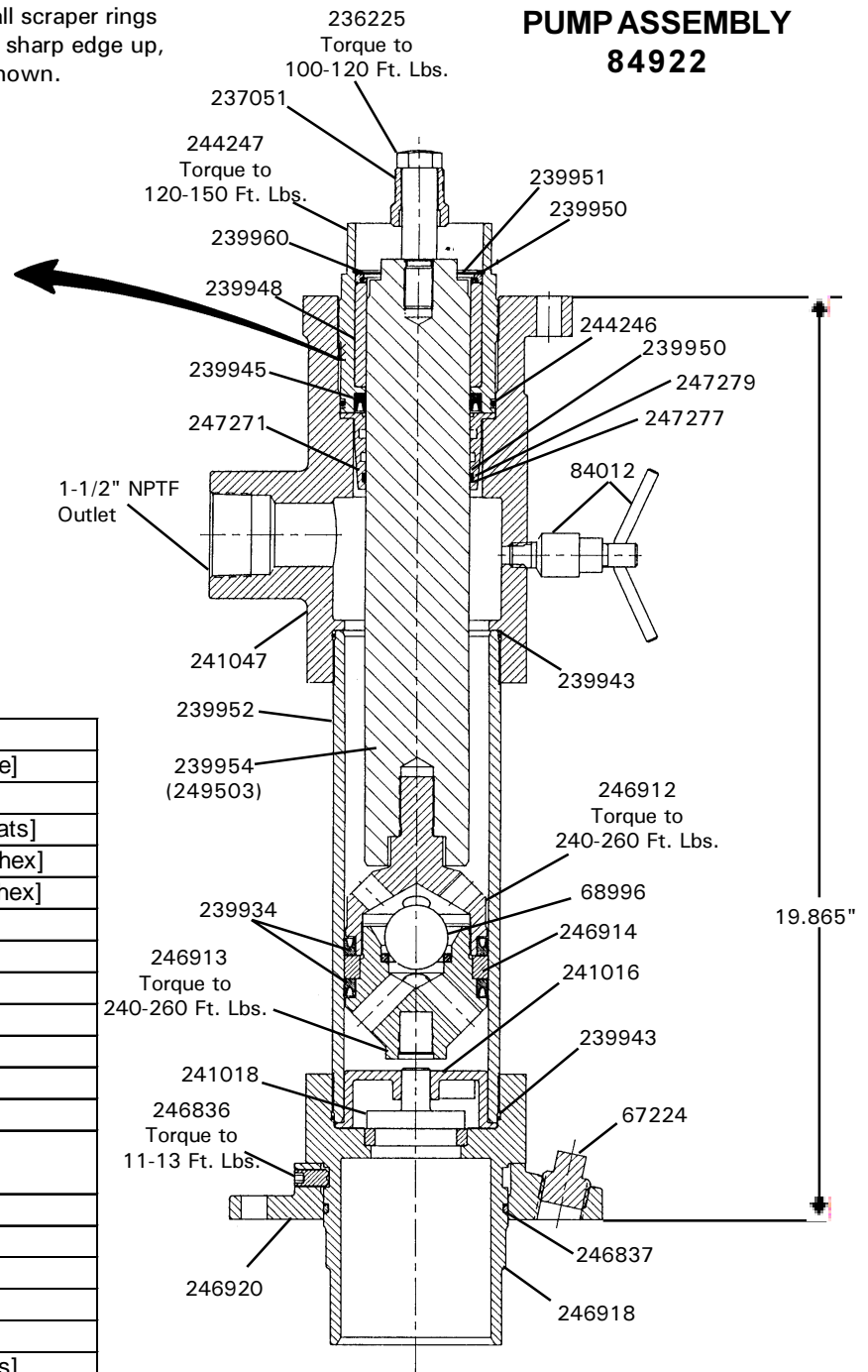

SERVICE PARTS

PART	QTY	DESCRIPTION
67224	1	Pipe plug [5/8" square]
68996	1	Check Ball
84012	1	Bleeder Valve [3/4" flats]
236225	1	Bolt Connector [7/8" hex]
237051	1	Coupling Nut [1-1/8" hex]
* ^ 239934	2	U-cup (polyurethane)
* ^ 239943	2	O-ring (polyurethane)
# * ^ 239945	1	U-cup (polyurethane)
239948	1	Bushing
^ 239950	2	Wiper
239951	1	Spacer
239952	1	Pump Tube
239954	1	Plunger [1-3/4" flats]
-249503		ø2.2500/2.2485©
^ 239960	1	Retaining Ring
240147	1	Outlet Body
241016	1	Check Guide
241018	1	Check
# * ^ 244246	1	O-ring (polyurethane)
244247	1	Gland Nut [3-1/8" flats]
246836	3	Set Screw [3/16" hex socket]
* ^ 246837	1	O-ring (nitrile)
246912	1	Piston Nut [2-3/4" flats]
246913	1	Piston Body [1-1/8" flats]
246914	1	Piston Collar
246918	1	Inlet Bushing [3-3/4" flats]
246920	1	Mounting Flange
^247277	1	Retaining Ring
247271	1	Sleeve
^247279	1	Washer

^ Included in 241681 Repair Kit

* Included in 84930 Seal Kit

Included in 85315 Gland Seal Kit

© Indicates Change

PUMPTUBE SERVICE KITS

	Polyurethan	Teflon	Polyethylene
Repair Kit	241681		
Seal Kit	84930	84931	84932
Gland Seal Kit	85315	85325	85331

Repair Kit contains all parts needed for complete pumptube rebuild.

Polyurethane Seal Kit contains all soft seals.

Teflon and Polyethylene Seal Kits contain gland and piston U-cups only.

Gland Seal kits contain gland U-cup and O-ring only.

TROUBLESHOOTING

Problem	Possible Cause	Solution
Pump does not operate.	Restricted or inadequate air supply.	Check air supply pressure and air hose diameter (see specifications for minimum air supply hose diameter).
	Obstructed material output.	Check output line for restrictions.
Erratic or accelerated operation.	Pump is not primed.	Prime pump (see "pump priming instructions").
	Insufficient material supply.	Refill material supply.
	Material is too heavy for priming.	Lower output with material valve. Increase pressure to pressure primer (if in use). Check for inlet restrictions.
Pump operates on "down" stroke only (missing "up" stroke).	Worn or damaged piston packing (239934) or piston check(68993 & 246913).	Check and replace if needed.
Pump operates on "up" stroke only (missing "down" stroke).	Worn or damaged inlet check (236231) or priming rod packing (34710).	Check and replace if needed.
	Insufficient material supply, pump is not intaking enough material to dispense on both strokes.	Check inlet for restrictions. lower output with material valve.
Pump is operating but not dispensing material.	Inlet check (236231) is not seating or damaged.	Check and replace if needed

DISASSEMBLY PROCEDURE

Tools Required	Used on Part #		
3/16" hex key	(246836)	<ol style="list-style-type: none"> 4. Remove Inlet Bushing 246918 from Pump Tube 239952. <ol style="list-style-type: none"> a. Remove O-ring 246837 from Inlet Bushing 246918. b. Remove O-ring 239943 from Inlet Bushing 246918. c. Remove Check Guide 241017 and check assembly from Inlet Bushing 246918. d. Remove Retaining Ring 69034 and Guide Washer 239946 from Check 236231. e. Remove Retaining Ring 68886 and U-cup 34710 from Check 236231. 5. Remove Bolt Connector 236225 from Plunger 239954. <ol style="list-style-type: none"> a. Slide Coupling Nut 237051 off Bolt Connector 236225. 6. Remove priming rod, piston and plunger assembly from bottom of Pump Tube 239952. <ol style="list-style-type: none"> a. Remove Adapter 16003 from Piston Body 246913. b. Remove Keepers 16008 and Adapter 16003 from Priming Rod 236227. c. Remove piston assembly from Plunger 239954. d. Remove Piston Nut 246912 and Check Ball 68996 from Piston Body 246913. e. Remove U-cup 239934 from Piston Nut 246912. f. Remove Piston Collar 246914 and U-cup 239934 from Piston Body 246913. 	<ol style="list-style-type: none"> 7. Remove Pump Tube 239952 from Outlet Body 241047. 8. Remove O-ring 239943 from Outlet Body 241047. 9. Remove Bleeder Valve 84012 from Outlet Body 241047. 10. Remove gland nut assembly from Outlet Body 241047. <ol style="list-style-type: none"> a. Remove O-ring 244246 and U-cup 239945 from Gland Nut 244247. b. Remove Retaining Ring 239960 from Gland Nut 244247. c. Remove Spacer 239951, Wiper 239950 and Bushing 239948 from Gland Nut 244247. 11. Remove Sleeve 247271, Scraper 239950, Washer 247279, and Retaining Ring 247277 from Outlet Body 241047. 12. To reassemble pump, reverse disassembly procedure. (Refer to illustration for torque specifications.)
1/2" wrench	(236227)		
3/4" wrench	(84012)		
7/8" wrench	(236225)		
1-1/8" wrench (237051 & 246913)			
1-3/4" wrench	(239954)		
2-3/4" wrench	(246912)		
3-1/8" wrench	(244247)		
3-3/4" wrench	(246918)		
3-5/8" dia. strap wrench	(239952)		
Internal retaining ring pliers	(68886)		
External retaining ring pliers	(69034)		
Screwdriver	(239960 & 247277)		
Procedure			
<ol style="list-style-type: none"> 1. Remove Set Screws 246836 from Mounting Flange 246920. 2. Remove Mounting Flange 246920 from Inlet Bushing 246918. <ol style="list-style-type: none"> a. Remove Priming Plug 93075 from Connector 13252. b. Remove Connector 13252 from Mounting Flange 246920. 3. Remove Priming Plunger Nut 241031 from Priming Rod 236227. 			

RETAIN THIS INFORMATION FOR FUTURE REFERENCE

When ordering replacement parts, list: Part Number, Description, Model Number and Series Letter.
LINCOLN provides a Distributor Network that stocks equipment and replacement parts.