

LINCOLN 8, 6, 4 1/4 & 3 IN. AIRMOTORS

OWNERS MANUAL

IT IS THE RESPONSIBILITY OF THE OWNER AND/OR OPERATOR TO PROPERLY USE AND MAINTAIN THIS EQUIPMENT. CAREFULLY READ AND UNDERSTAND THE INSTRUCTIONS AND WARNINGS IN THIS MANUAL BEFORE OPERATING THIS EQUIPMENT.

If the operator is not fluent in English, the instructions and warnings shall be read and discussed in the operator's native language, making sure the operator comprehends the contents.

This equipment complies with OSHA Standards where applicable.



WARNING

DO NOT exceed the stated maximum working pressure of the airmotor or of the lowest rated component in your system.

DO NOT alter or modify any part of this equipment.

DO NOT operate this equipment with combustible gas.

DO NOT attempt to repair or disassemble the equipment while the system is pressurized.

TIGHTEN all fluid connections securely before using this equipment.

ALWAYS read and follow the fluid manufacturer's recommendations regarding fluid compatibility, and the use of protective clothing and equipment.

CHECK all equipment regularly and repair or replace worn or damaged parts immediately.

IMPORTANT: Failure to heed these warnings including misuse, overpressurizing, modifying parts, using incompatible chemicals and fluids, or using worn or damaged parts, may result in equipment damage and/or serious personal injury, fire, explosion, or property damage.

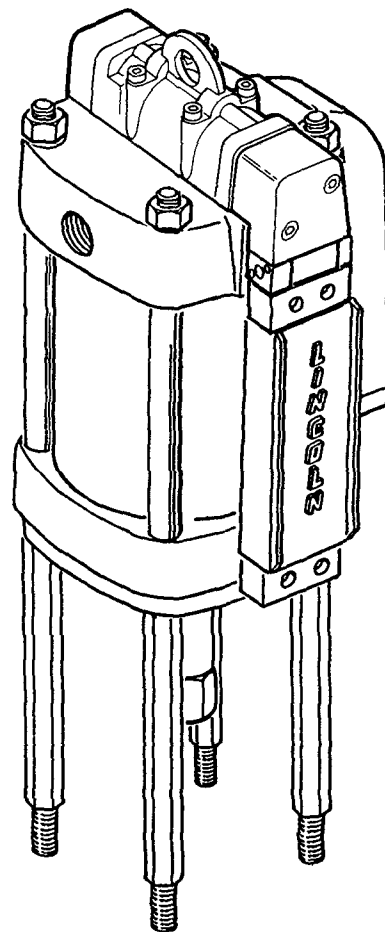

This manual contains **IMPORTANT WARNINGS** and **INSTRUCTIONS** READ AND RETAIN FOR REFERENCE.

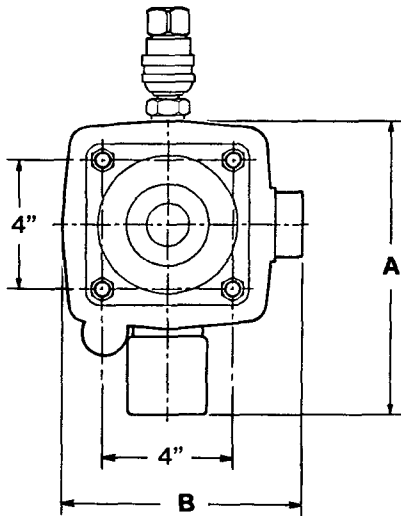
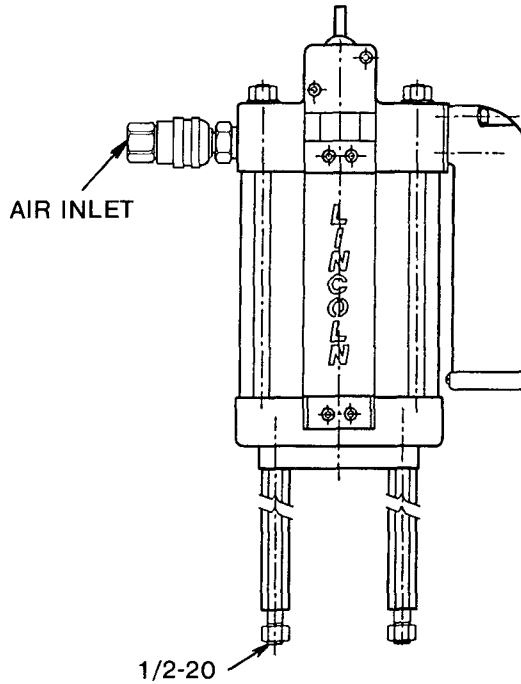
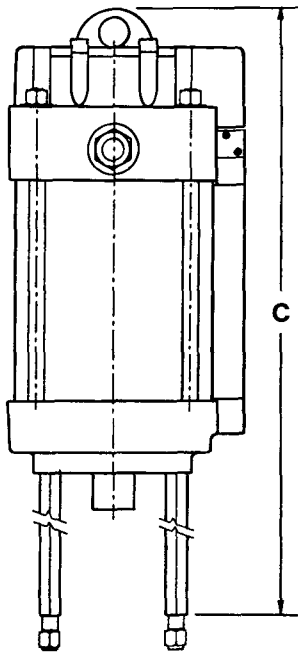

NOTE:
Use only with 6 in. (152 mm) stroke Pump Tubes. DO NOT OPERATE with air contaminated with materials not compatible with BUNA-N Seals.

© Indicates Change

SPECIFICATIONS

MODEL	CYLINDER DIAMETER IN. (MM)	EFFECTIVE PISTON AREA IN ² (CM ²)	OPERATING PRESSURE RANGE PSIG (BAR)	OPERATING TEMP. RANGE °F (°C)	MIN. I.D. OF AIR SUPPLY IN. (MM)	AIR INLET	AIR CONS. AT 75 CPM @ 100 PSIG SCFM
84808	8 (203)	50 (324)	30-100 (2-7)	30 - 200 (-34 - +93)	3/4 (20)	3/4" NPTF	160
84806	6 (152)	28 (182)			1/2 (12)	3/4" NPTF	105
84804	4-1/4 (108)	14 (92)	30-200 (2-14)	30 - 200 (-34 - +93)	1/2 (12)	1/2" NPTF	65
84803	3 (76)	7 (46)			3/8 (10)	1/2" NPTF	40
MODEL	MAX. RECOM. SPEED CPM	STROKE LENGTH IN. (MM)	WEIGHT LB. (KG)	SEALS MATERIAL	DIM. A IN. (MM)	DIM. B IN. (MM)	DIM. C IN. (MM)
84808	75	6 (152)	46.5 (21)	BUNA-N and *TEFLON®	11-1/4 (286)	9-9/16 (243)	22-3/4 (577) ©
84806			33 (15)		9-1/4 (235)	7-3/4 (197)	22-3/4 (577) ©
84804			22 (10)		7-1/2 (191)	6 (152)	23-5/8 (599) ©
84803			22 (10)		7-1/2 (191)	6 (152)	23-5/8 (599) ©

*TEFLON® Seals used with Power Valve Spool (Item 13) and Relay Valve (Item 17).

SERVICE ASSEMBLIES & KITS

To reduce down-time and take advantage of the modular design of the airmotor, Lincoln recommends using the following Service Assemblies for repair of the airmotor. After removal, the faulty assembly can then be repaired using the corresponding Soft Parts Kit.

1. Pilot Bar Subassembly

P/N 242786 (4-1/4", 6" & 8" Airmotor)

P/N 242799 (3" Airmotor)

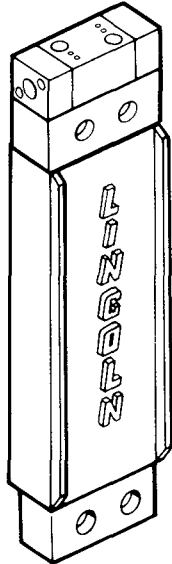

2. Soft Parts Kit P/N 84967 for repair of Pilot Bar Subassemblies listed above. (Includes all necessary "O"-rings.)

3. Relay Valve P/N 242787

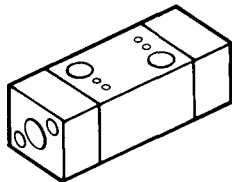

4. Air Signal Valve P/N 241768

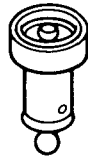

5. Cylinder Tube Soft Parts Kit
(Includes all "O"-rings, piston seal, etc. ...)

P/N 84791 (8" Airmotor)

P/N 84792 (6" Airmotor)

P/N 84793 (4-1/4" Airmotor)

P/N 84794 (3" Airmotor)

6. Muffler with Gasket P/N 242788

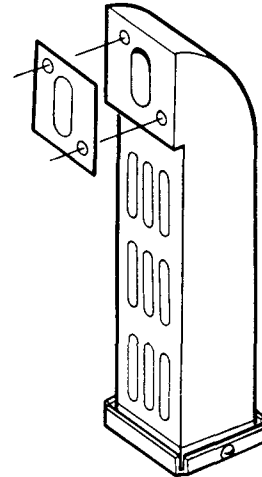

7. Muffler Element Kit P/N 84939 for repair of Muffler listed above. (Includes element, felts and gasket.)

8. Power Valve Subassembly

P/N 244804 (8" Airmotor)

P/N 244806 (6" Airmotor)

P/N 244808 (3" & 4-1/4" Airmotor)

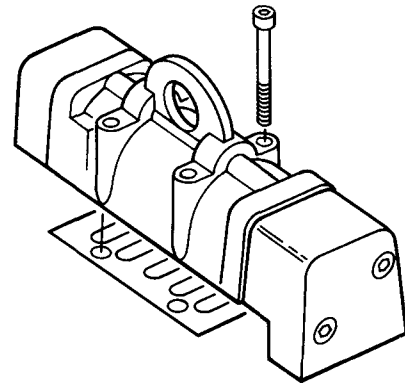

9. Soft Parts Kit P/N 84968 for repair of Power Valve Subassemblies listed above.

10. Power Valve Spool & Body P/N 244802

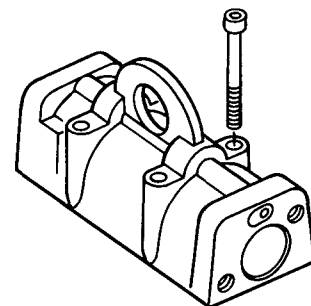

IMPORTANT: When replacing soft parts, replace all parts included in the soft parts kit.



WARNING

ALWAYS check equipment for proper operation before each use, making sure safety devices are in place and operating properly. **DO NOT** alter or modify any part of the equipment as this may cause a malfunction and result in serious bodily injury.

BEFORE CONNECTING AIRMOTOR TO AIR LINE

LINCOLN AIRMOTORS are fully pneumatic operational and require minimum specified size of air supply hose for proper operation. Check specification for minimum I.D. of the air supply hose and select corresponding sizes of air controls and accessories for non-restrictive air flow. Lincoln filter, regulator with gauge and lubricators are available as combination units (FRL).

For 3/8" air line - Model 83387-6
For 1/2" air line - Model 83387-8
For 3/4" air line - Model 83387-12

If quick disconnect coupling should be used, install supplied coupler to insure proper airmotor operation.

NOTE: Whenever flammable materials are pumped, ground Airmotor according to Local Codes.

OPERATING PRECAUTIONS

Use Lincoln replacement parts to assure compatible pressure rating.

Heed ALL warnings.

DO NOT OPERATE Airmotor continuously at speeds exceeding 75 cycles per minute.

DO NOT OPERATE Airmotor in excess of recommended pressure range.

Disconnect air line and relieve (vent) pressure when Airmotor sits idle for long periods of time and before servicing.



WARNING

ALWAYS read and follow the fluid and solvent manufacturer's recommendations regarding the use of protective clothing and equipment.



WARNING

To reduce the risk of serious bodily injury or property damage, **NEVER** exceed the maximum air or fluid working pressure of the lowest rated system component.

ATTACHING AIRMOTOR TO PUMPTUBE

1. Tightly attach the tie rods (Item 41) to the Airmotor lower casting. Use short threaded end of tie rods.
2. Mount Airmotor on top of pump tube outlet and tightly connect pump tube coupling nut to Airmotor Piston Rod (Item 5).
3. Hand tighten tie rods to the pump tube with four nuts (Item 42) supplied with Airmotor.
4. Connect air supply and slowly cycle pump several times using only enough air pressure to operate pump without stalling.
5. **STOP** pump on "UP" stroke and tighten four nuts to securely fasten Airmotor to pump tube.

SERVICE AND DISASSEMBLY PROCEDURE



WARNING

Always disconnect air supply to Airmotor and relieve pressure before checking, servicing, or repairing any part of Airmotor

TOOLS REQUIRED

1. 7/64 (.109) Hex Wrench
2. 5/32 (.156) Hex Wrench
3. 3/16 (.189) Hex Wrench
4. 3/4 (.750) Open End Wrench (for 6" Airmotor)
5. 15/16 (.937) Open End Wrench (for 8" Airmotor)
6. 1/2 (.500) Open End Wrench (for 4-1/4" and 3" Airmotor)
7. Pliers

The modular design of the Airmotor and accessibility of vital operation parts make service available without taking Airmotor out of line or without complete disassembly.

Power Valve

1. Remove four screws (Items 27 & 34) with 3/16" hex wrench (2 on each side).
2. Remove End Caps (Items 10 & 14).
3. Push out Valve Spool (Item 13).
4. Remove Spool Bumpers (Item 9) (One from each end).
5. Remove "O" Ring (Item 11) (One from each end of valve body).
6. Remove four Screws (Item 37) with 3/16" hex wrench and lift valve body (Item 12).
7. Remove Gasket (Item 15) to complete valve disassembly.
8. To REASSEMBLE, REVERSE procedure.

Pilot Bar Subassembly

1. Remove four Screws (Item 23) (two on each end) with 3/16" hex wrench and pull out Pilot Bar Subassembly.
2. Remove two Screws (Item 39), with 7/64" hex wrench and lift out Valve Body (Item 17).
3. Remove four Screws (Item 40) (two on each end of Pilot Bar) and lift off Upper Bracket (Item 31) and Lower Bracket (Item 32).
4. Remove Air Signal Valves (Item 20).
5. To REASSEMBLE, REVERSE procedure.

Cylinder Tube and Muffler

1. Remove Pilot Bar Subassembly (See Above).
2. Remove two Screws (Item 30) with 3/16" hex wrench and pull off muffler (Item 29).
3. Remove Gasket (Item 28).
4. Remove four Nuts (Item 26) with open end wrench.
5. Lift upward and remove Upper Casting (Item 8).
6. Remove four Tie Rods (Item 25).
7. Remove Air Tube (Item 7).
8. Lift upward and remove Cylinder Tube (Item 6).
9. Remove Piston and Piston Rod (Item 5).
10. Remove four Connecting Rods (Item 41) with open end wrench.
11. To REASSEMBLE, REVERSE procedure.

NOTE: Align two holes on the Cylinder Tube (Item 6) with two holes on the Pilot Bar (Item 24) before tightening Tie Rods (Items 25) so that proper seal with "O" rings is achieved.

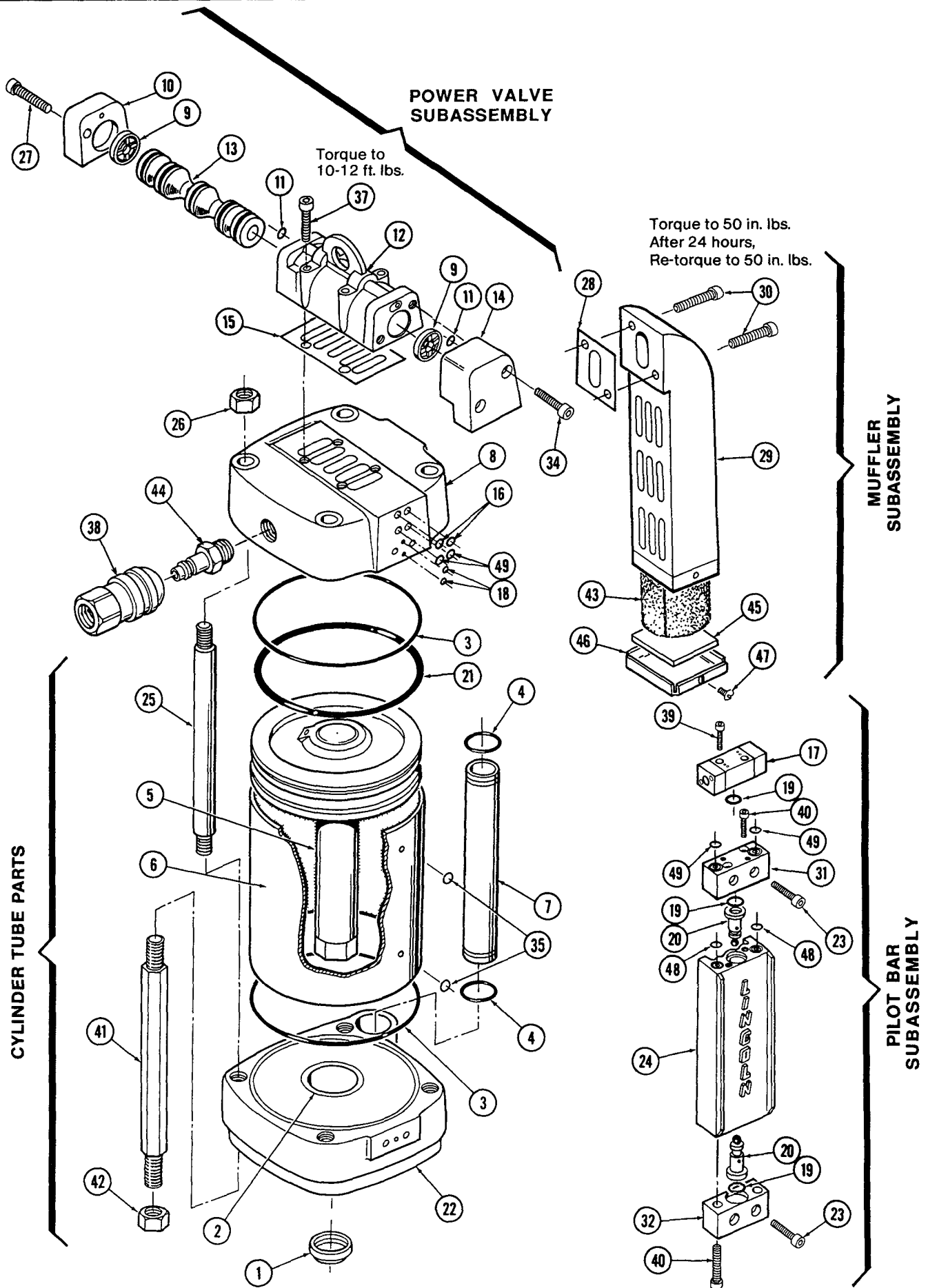

NOTE: Refer to Page 3 for Service Assemblies & Kits.

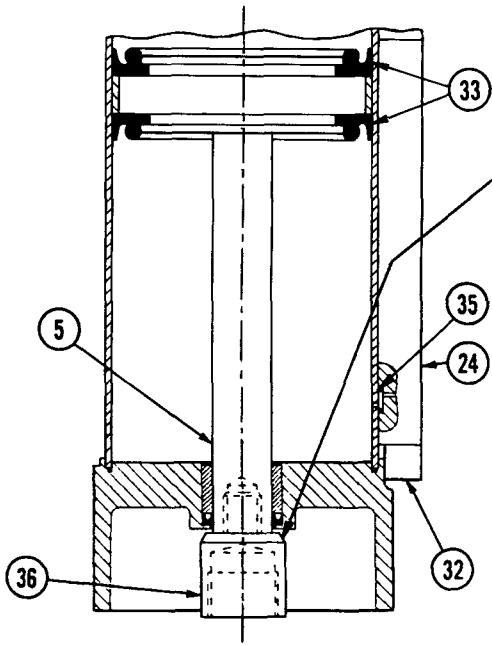

Assemble Adapter to Piston Rod
Using Loctite #242 Blue on threads.
Torque to 60-65 Ft. Lbs.

MODELS 84803 and 84804

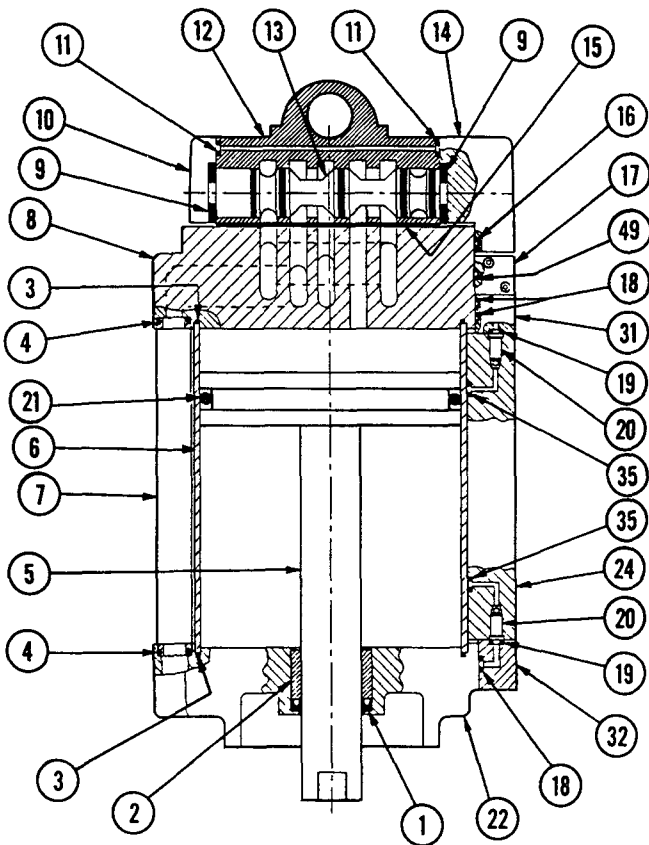
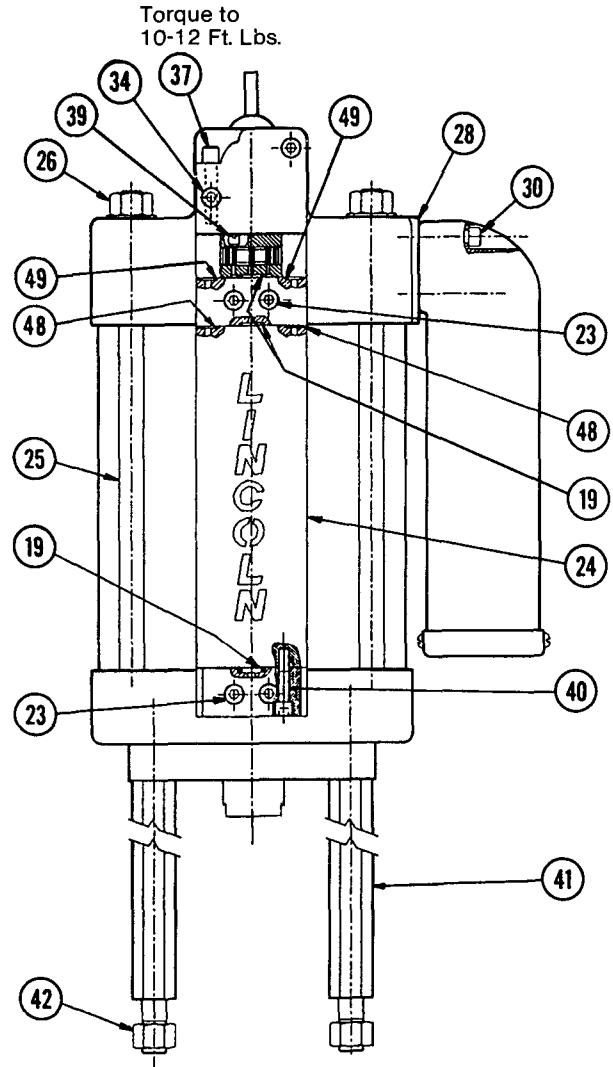

MODELS 84806 and 84808

PARTS LIST

ITEM NO.	DESCRIPTION	(QTY.)	PART NUMBER			
			MODEL 84808 (8" DIA.)	MODEL 84806 (6" DIA.)	MODEL 84804 (4-1/4" DIA.)	MODEL 84803 (3" DIA.)
1	"U" Cup (Buna-N)	(1)	(Note #1)	(Note #2)	(Note #3)	(Note #4)
2	Rod Bearing	(1)	241732	241732	241733	241733
3	Seal, Cylinder (Buna-N)	(2)	(Note #1)	(Note #2)	(Note #3)	(Note #4)
4	"O"-ring (Buna-N)	(2)	(Note #1)	(Note #2)	(Note #3)	(Note #4)
5	Piston Rod Assembly	(1)	241740	241741	241742	241743
6	Cylinder Tube	(1)	241744	241745	241746	241747
7	Air Tube	(1)	241748	241748	241749	241749
8	Upper Casting	(1)	241750	241751	241752	241753
9	Bumper, Valve	(2)	(Note #7)	(Note #7)	(Note #7)	(Note #7)
10	Cap, Valve	(1)	241755	241755	241755	241755
11	"O"-ring (Buna-N)	(2)	(Note #7)	(Note #7)	(Note #7)	(Note #7)
12	Body, Valve	(1)	244658	244658	244658	244658
13	Spool, Valve	(1)	241758	241758	241758	241758
14	Cap, Valve	(1)	241759	241760	241761	241761
15	Gasket	(1)	(Note #7)	(Note #7)	(Note #7)	(Note #7)
16	"O"-ring (Buna-N)	(2)	(Note #7)	(Note #7)	(Note #7)	(Note #7)
17	Relay Valve	(1)	242787	242787	242787	242787
18	"O"-ring (Buna-N)	(3)	(Note #6)	(Note #6)	(Note #6)	(Note #6)
19	"O"-ring (Buna-N)	(3)	(Note #6)	(Note #6)	(Note #6)	(Note #6)
20	Air Signal Valve	(2)	241768	241768	241768	241768
21	"O"-ring, Piston (Buna-N)	(1)	(Note #1)	(Note #2)	-----	-----
22	Lower Casting	(1)	241773	241774	241775	241776
23	Screw (1/4-20 x 7/8")	(4)	50526	50526	50526	50526
24	Pilot Bar	(1)	241778	241778	241778	241788
25	Tie Rod	(4)	241766	241779	241767	241767
26	Nut	(4)	51018	51007	51001	51001
27	Screw	(2)	50521	50521	50521	50521
28	Gasket	(1)	(Note #5)	(Note #5)	(Note #5)	(Note #5)
29	Muffler Body	(1)	241021	241021	241021	241021
30	Screw (1/4-20 x 1-1/2")	(2)	50051	50051	50051	50051
31	Bracket, Upper	(1)	241784	241784	241784	241784
32	Bracket, Lower	(1)	241785	241785	241785	241785
33	Seal, Piston	(2)	-----	-----	(Note #3)	(Note #4)
34	Screw	(2)	50521	241783	241783	241783
35	"O"-ring (Buna-N)	(2)	(Note #6)	(Note #6)	(Note #6)	(Note #6)
36	Adapter	(1)	-----	-----	241789	241789
37	Screw (1/4-20 x 2-1/4")	(4)	244975	244975	244975	244975
38	Coupler	(1)	652012	652012	652008	652008
39	Screw (6-32)	(2)	50816	50816	50816	50816
40	Screw (1/4-20)	(4)	50823	50823	50823	50823
41	Tie Rod	(4)	241023	241023	241023	241023
42	Nut (1/2-20)	(4)	236203	236203	236203	236203
43	Muffler Element	(1)	(Note #5)	(Note #5)	(Note #5)	(Note #5)
44	Nipple	(1)	650112	650112	650112	650112
45	End Element	(1)	(Note #5)	(Note #5)	(Note #5)	(Note #5)
46	Muffler Plate	(1)	241027	241027	241027	241027
47	Screw, Self Tapping (10-32)	(2)	66962	66962	66962	66962
48	"O"-ring (Buna-N)	(2)	(Note #6)	(Note #6)	(Note #6)	(Note #6)
49	"O"-ring (Buna-N)	(4)	(Note #6)	(Note #6)	(Note #6)	(Note #6)

- NOTES:**
1. Included in 84791 Cylinder Tube Soft Parts Kit for Model 84808 (8" Airmotor).
 2. Included in 84792 Cylinder Tube Soft Parts Kit for Model 84806 (6" Airmotor).
 3. Included in 84793 Cylinder Tube Soft Parts Kit for Model 84804 (4-1/4" Airmotor).
 4. Included in 84794 Cylinder Tube Soft Parts Kit for Model 84803 (3" Airmotor).
 5. Included in 84939 Muffler Element Kit.
 6. Included in 84967 Soft Parts Kit for Pilot Bar Subassembly.
 7. Included in 84968 Soft Parts Kit for Power Valve Subassembly.

TROUBLESHOOTING

PROBLEM	POSSIBLE CAUSE	SOLUTION
Airmotor is not working and air is coming from exhaust.	Restricted or inadequate air supply.	Check air supply and adjust to minimum recommended level. Check air supply hose diameter and change it to minimum recommended size (see specifications). Check size of FRL and quick disconnect coupling. Replace if small size or restricted.
Erratic or accelerated operation with short stroking.	Dirty or damaged Relay Valve (Item 17) or Air Signal Valve (Item 20).	Check valves and clean if necessary. Replace any damaged seals or worn parts.

LINCOLN LUBRICATING EQUIPMENT LIMITED WARRANTY

Lincoln, A Pentair Company, warrants that lubrication equipment, materials dispensing equipment and other related equipment manufactured by it will be free from defects in material and workmanship during the one (1) year following the date of purchase. If equipment proves to be defective during this warranty period, it will be repaired or replaced without charge, provided that factory examination indicates the equipment to be defective. To obtain repair or replacement, it must be shipped, transportation charges prepaid, with proof of date of purchase to a Lincoln authorized Warranty and Service Center, within the one (1) year following the date of purchase.

This warranty is extended to the original retail purchaser only. This warranty does not apply to equipment damaged from accident, overload, abuse, misuse, negligence, faulty installation or abrasive or corrosive materials, or to equipment repaired or altered by anyone not authorized by Lincoln to repair or alter the equipment. This warranty applies only to equipment installed and operated according to the recommendations of Lincoln or its authorized field personnel. No other express warranty applies to lubrication equipment, materials dispensing equipment, and other related equipment manufactured by Lincoln.

ANY IMPLIED WARRANTIES applicable to lubrication equipment, materials dispensing equipment, and other related equipment manufactured by Lincoln INCLUDING THE WARRANTIES OF MERCHANTABILITY AND FITNESS FOR A PARTICULAR PURPOSE, WILL LAST ONLY FOR ONE (1) YEAR FROM THE DATE OF PURCHASE. SOME STATES DO NOT ALLOW LIMITATIONS ON HOW LONG AN IMPLIED WARRANTY LASTS, SO THE ABOVE LIMITATION MAY NOT APPLY TO YOU.

In no event shall Lincoln be liable for incidental or consequential damages. The liability of Lincoln on any claim for loss or damage arising out of the sale, resale, or use of lubrication equipment, materials dispensing equipment, and other related equipment shall in no event exceed the purchase price. SOME STATES DO NOT ALLOW THE EXCLUSION OR LIMITATION OF INCIDENTAL OR CONSEQUENTIAL DAMAGES, SO THE ABOVE LIMITATION OR EXCLUSION MAY NOT APPLY TO YOU.

THIS WARRANTY GIVES YOU SPECIFIC LEGAL RIGHTS AND YOU MAY ALSO HAVE OTHER RIGHTS WHICH VARY FROM STATE TO STATE.

RETAIN THIS INFORMATION FOR FUTURE REFERENCE

When ordering replacement parts, list: Part Number, Description, Model Number, and Series Letter.

LINCOLN provides a Distributor Network that stocks equipment and replacement parts.