



**Models 84991, 84992, 84993, 84994, 84995
84996, 84997, 84998, 85201, 85202
POWER-MASTER III DRUM PUMPS
Bushing & Plunger / Shovel Type Foot Valve**

OWNER/OPERATOR MANUAL

It is the responsibility of the Owner/Operator to properly use and maintain this equipment.

The Instructions and Warnings contained in this manual shall be read and understood by the Owner/Operator prior to operating this equipment.

It is the responsibility of the Owner/Operator to maintain the legibility of all Warning and Instruction labels.

The Owner/Operator shall retain this manual for future reference to important Warnings, Operating and Maintenance Instructions.

⚠ WARNING

DO NOT operate these pumps with 10" airmotor.

DO NOT exceed the stated maximum working pressure of the airmotor or the lowest rated component in your system.

DO NOT alter or modify any part of this equipment.

DO NOT operate this equipment with combustible gas.

DO NOT attempt to repair or disassemble the equipment while the system is pressurized.

TIGHTEN all fluid connections securely before using this equipment.

ALWAYS read and follow the fluid manufacturer's recommendations regarding fluid compatibility, and the use of protective clothing and equipment.

CHECK all equipment regularly and repair or replace worn or damaged parts immediately.

IMPORTANT: Failure to heed these warnings including misuse, overpressurizing, modifying parts, using incompatible chemicals and fluids, or using worn or damaged parts, may result in equipment damage and/or serious personal injury, fire, explosion, or property damage.

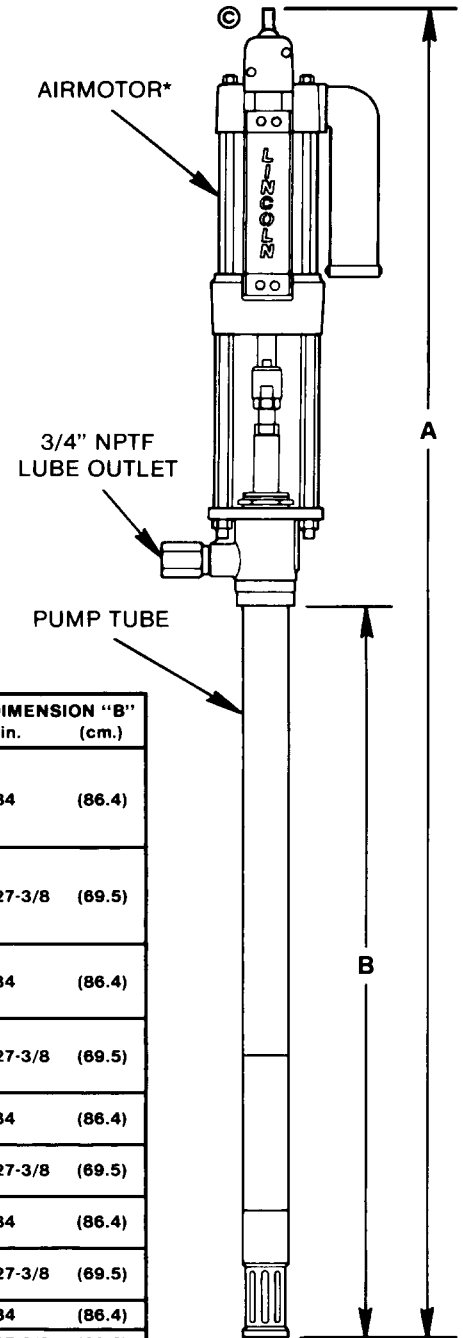

MODEL CHART ©

PUMP TUBE	PUMP MODEL	AIRMOTOR*	RATIO	MAXIMUM DELIVERY PRESSURE	MAXIMUM AIR PRESSURE	DIMENSION "A" in. (cm.)	DIMENSION "B" in. (cm.)
84991	2062	84808	84:1	8400 psi (580 bar)	100 psi (7 bar)	61-1/4 (155.6)	34 (86.4)
	2022	84806	48:1	4800 psi (331 bar)	200 psi (14 bar)	62-1/8 (157.8)	
	2002	84804	24:1	4800 psi (331 bar)			
	2042	84803	12:1	2400 psi (166 bar)			
84992	2063	84808	84:1	8400 psi (580 bar)	100 psi (7 bar)	54-5/8 (138.8)	27-3/8 (69.5)
	2026	84806	48:1	4800 psi (331 bar)	200 psi (14 bar)	55-1/2 (141.0)	
	2006	84804	24:1	4800 psi (331 bar)			
	2046	84803	12:1	2400 psi (166 bar)			
84993	2023	84806	80:1	8000 psi (552 bar)	100 psi (7 bar)	61-1/4 (155.6)	34 (86.4)
	2003	84804	40:1	8000 psi (552 bar)	200 psi (14 bar)	62-1/8 (157.8)	
	2043	84803	20:1	4000 psi (276 bar)			
84994	2027	84806	80:1	8000 psi (552 bar)	100 psi (7 bar)	54-5/8 (138.8)	27-3/8 (69.5)
	2007	84804	40:1	8000 psi (552 bar)	200 psi (14 bar)	55-1/2 (141.0)	
	2047	84803	20:1	4000 psi (276 bar)			
84995	2010	84804	50:1	7500 psi (517 bar)	150 psi (10 bar)	62-1/8 (157.8)	34 (86.4)
	2044	84803	24:1	4800 psi (331 bar)	200 psi (14 bar)		
84996	2011	84804	50:1	7500 psi (517 bar)	150 psi (10 bar)	55-1/2 (141.0)	27-3/8 (69.5)
	2048	84803	24:1	4800 psi (331 bar)	200 psi (14 bar)		
84997	2004	84804	75:1	7500 psi (517 bar)	100 psi (7 bar)	62-1/8 (157.8)	34 (86.4)
	2045	84803	36:1	7200 psi (497 bar)	200 psi (14 bar)		
84998	2008	84804	75:1	7500 psi (517 bar)	100 psi (7 bar)	55-1/2 (141.0)	27-3/8 (69.5)
	2049	84803	36:1	7200 psi (497 bar)	200 psi (14 bar)		
85201	2053	84803	50:1	7500 psi (517 bar)	150 psi (10 bar)	62-1/8 (157.8)	34 (86.4)
85202	2054	84803	50:1	7500 psi (517 bar)	150 psi (10 bar)	55-1/2 (141.0)	27-3/8 (69.5)

* Refer to Airmotor Owner/Operator Manual, Section A50 Page 78.

© Indicates Change



One Lincoln Way
St. Louis, Missouri 63120-1578
(314) 679-4200

Copyright 1994
Printed in U.S.A.

Section - A50
Page - 82B

ATTACHING AIRMOTOR TO PUMPTUBE

1. Tightly attach tie rods to the airmotor (use short threaded end of the tie rods).
2. Mount airmotor on top of the pump-tube outlet and tightly connect Coupling Nut (Item 2) to airmotor piston rod.
3. Hand tighten tie rods to the pumptube with four nuts supplied with airmotor.
4. Slowly cycle the pump several times, using just enough air pressure to operate the pump without stalling.
5. Stop the pump on an "up" stroke and tighten the four nuts to securely fasten the airmotor to the pumptube.

OPERATING PRECAUTIONS

- Use Lincoln replacement parts to assure compatible pressure rating.
- HEED ALL WARNINGS.
- Be sure material hoses and other components are able to withstand fluid pressures developed by this pump.
- Do not operate pump continuously at speeds in excess of 75 cycles per minute.
- Disconnect air line from pump airmotor when system sits idle for long periods of time.
- SERVICING. Before servicing or cleaning pump, or removing fluid hose or gun from a unit that has been used, be sure to disconnect air lines and carefully bleed pressure off of the system.



WARNING

PREVENT STATIC SPARKING. If static sparking occurs, fire or explosion could result. Pump, dispensing valve, and containers must be grounded when handling flammable fluids such as petroleum products, paints, lacquers, etc. and wherever discharge of static electricity is hazard.

- Check continuity (a good static wire connection) with an ohmmeter. Place one probe on one hose fitting and the other probe on other hose fitting, continuity or proper grounding through hose is good when a reading is obtained on the ohmmeter.
- PREVENT FIRES. When pumping, flushing or recirculating volatile solvents, the area must be adequately ventilated.
- Keep solvents away from heat, sparks and open flames. Keep containers closed when not in use.



CAUTION

DO NOT allow pump to operate when out of material.

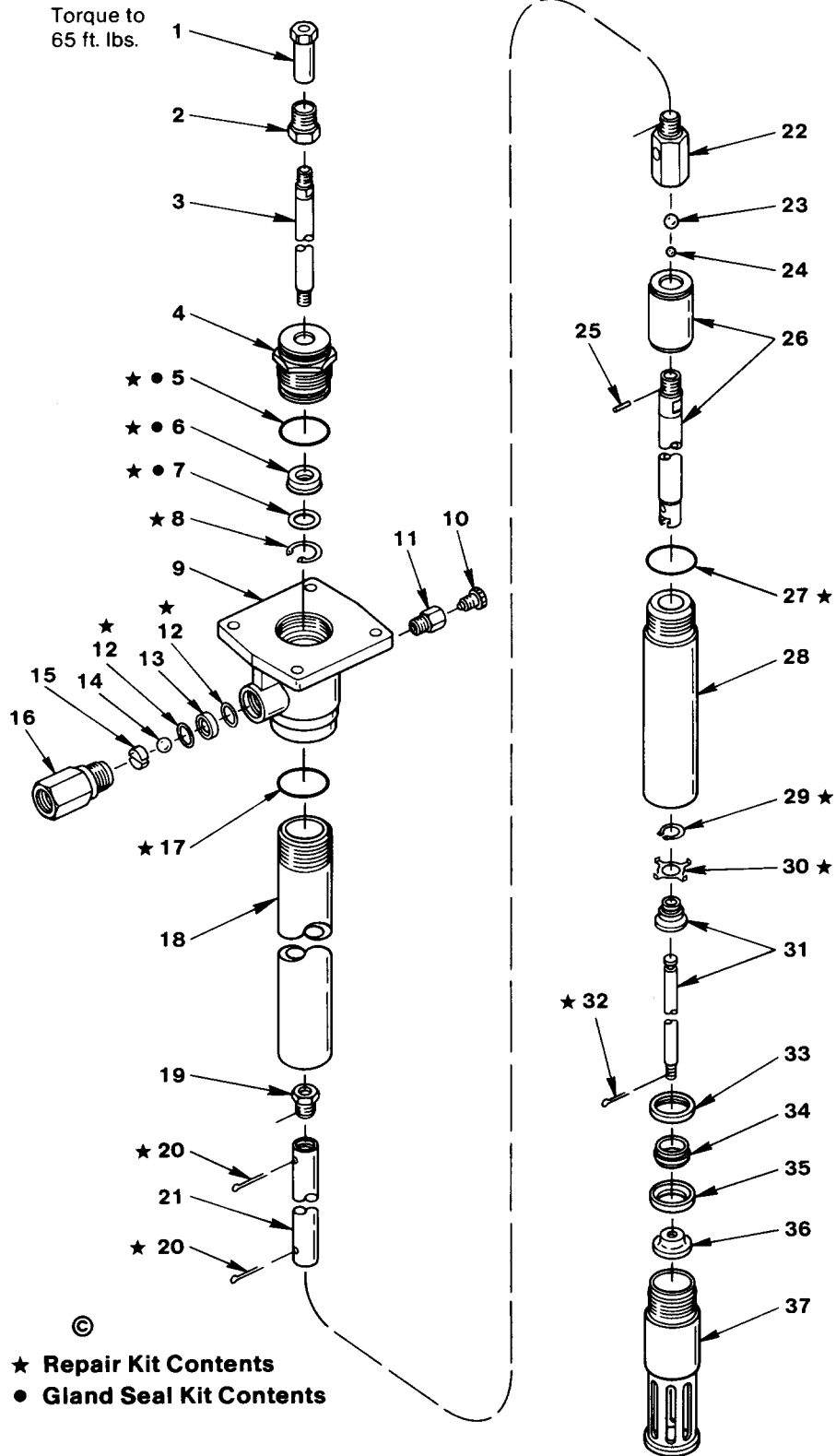

PUMP PRIMING

To begin operation, the pump has to be primed with the pumped material. The Power-Master III pump is a double acting (pumps material on "up" & "down" stroke) positive displacement reciprocating pump and as such intakes material only on the "up" stroke.

To prime pump, open output line (material valve) and slowly open air supply valve until pump starts. Allow pump to cycle very slowly until all air is

pushed out of lines and material fills up pump and lines. Close output line (material shut-off valve) - pump should stall against pressure.

Note: Pumps are factory tested with light oil and some of it is left in to protect pump parts during storage and transportation. To prevent contamination of material to be pumped, flush pump before using.

DISASSEMBLY

Tools Required

2-1/8" Dia. Strap Wrench
Retaining Ring Pliers (External)
Retaining Ring Pliers (Internal)
19/32" Hex Wrench
5/8" Hex Wrench
11/16" Hex Wrench
7/8" Hex Wrench
13/16" Hex Wrench
1-3/8" Hex Wrench
2-1/4" Hex Wrench
Pliers

Procedure

1. Unscrew Adapter Tube (Item 28) from Pump Tube (Item 18).
2. Pull on Adapter Tube (Item 28) until connection between Bushing & Plunger (Item 26) and Bushing & Plunger (Item 31) is exposed and can be disconnected.
3. Remove Priming Tube (Item 37) from Adapter Tube (Item 28).
4. Remove Lower Check Assembly (Items 29, 30, 31, 33, 34 & 35) from Adapter Tube (Item 28).
5. Remove Cotter Pin (Item 32) from Bushing & Plunger (Item 31).

6. Remove Priming Shovel (Item 36) from Bushing & Plunger (Item 31).
7. Remove Retaining Ring (Item 29) and Guide Washer (Item 30) from Bushing & Plunger (Item 31).
8. Remove O-ring (Item 27) from Pump Tube (Item 18).
9. Remove Bolt Connector (Item 1) from Plunger (Item 3).
10. Pull Bushing & Plunger (Item 31) to remove Plunger (Item 3), Connecting Rod (Item 21), Adapter (Item 22) and Bushing & Plunger from Pump Tube (Item 18).
11. Remove Pump Tube (Item 18) from Outlet Body (Item 9).
12. Remove O-ring (Item 17) from Outlet Body (Item 9).
13. Remove Gland Nut (Item 4) from Outlet Body (Item 9).
14. Remove Priming Plug (Item 10) and Adapter (Item 11) from Outlet Body (Item 9).
15. Remove Outlet Body (Item 16) from Outlet Body (Item 9).

16. Remove Ball (Item 14), Check Seat (Item 13), and Gaskets (Item 12) from Outlet Body (Item 9).
17. Remove Retaining Ring (Item 8), Packing Washer (Item 7) and U-cup Packing (Item 6) from Gland Nut (Item 4).
18. Remove Bushing & Plunger (Item 31) from Adapter (Item 22).
19. Remove Ball (Item 23) from Adapter (Item 22).
20. Remove Pin (Item 25) and Ball (Item 24) from Bushing & Plunger (Item 31). **Note:** Models 85201 & 85202 do not have Items 24 & 25.
21. Remove Cotter Pins (Item 20) from Connecting Rod (Item 21).
22. Remove Adapter (Item 22) and Plunger (Item 3) from Connecting Rod (Item 21). **Note:** On Models 84997 & 84998 there is an Adapter (Item 19) between the Plunger & Connecting Rod.
23. To re-assemble pump, reverse disassembly procedure. (Refer to illustration for torque specifications.)

TROUBLESHOOTING

Problem	Possible Cause	Solution
Pump does not operate.	Restricted or inadequate air supply. Obstructed material output.	Check air supply pressure and air hose diameter (see Airmotor manual for minimum air supply hose diameter). Check output line for restrictions.
Erratic or accelerated operation.	Pump is not primed. Insufficient material supply. Material is too heavy for priming.	Prime pump (see "Pump Priming" instructions). Refill material supply. Lower output with material valve. Increase pressure to pressure primer (if in use). Check for inlet restrictions.
Pump operates on "down" stroke only (missing "up" stroke).	Worn or damaged Bushing & Plunger (Item 26) or Piston Check (Items 23, 24 & 26).	Check and replace if needed.
Pump operates on "up" stroke only (missing "down" stroke).	Worn or damaged Inlet Check (Items 34 & 35). Insufficient material supply. Pump is not intaking enough material to dispense on both strokes.	Check and replace if needed. Check inlet for restrictions. Lower output with material valve.
Pump is operating but not dispensing material.	Inlet Check (Items 34 & 35) is not seating or is damaged.	Check and replace if needed.

ACCESSORIES

- © **86218 Gland Protection Sleeve** - To increase life of gland seal, for Models 84991 & 84992.
86216 Gland Protection Sleeve - To increase life of gland seal, for Models 84993 & 84994.
86217 Gland Protection Sleeve - To increase life of gland seal, for Models 84995 & 84996.
86215 Gland Protection Sleeve - To increase life of gland seal, for Models 84997 & 84998.
86238 Gland Protection Sleeve - To increase life of gland seal, for Models 85201 & 85202.
86213 Lube Cup - For solvent, to prevent material from drying on pump rod.

SPECIFICATIONS

Pump stroke - 6 in. (152 mm)

Max. recommended speed (continuous) - 75 cycles/min.

Output per cycle:

- 84991 & 84992 - 6.1 cu. in. (100 cc)
- 84993 & 84994 - 3.7 cu. in. (61 cc)
- 84995 & 84996 - 3.0 cu. in. (49 cc)
- 84997 & 84998 - 2.1 cu. in. (34 cc)
- 85201 & 85202 - 1.3 cu. in. (21 cc)

Approx. cycles per gallon (liter):

- 84991 & 84992 - 38 (10)
- 84993 & 84994 - 63 (16)
- 84995 & 84996 - 78 (20)
- 84997 & 84998 - 111 (29)
- 85201 & 85202 - 178 (48)

Output at 75 cycles/min.:

- 84991 & 84992 - 2.0 gpm (7.5 liter/min.)
- 84993 & 84994 - 1.2 gpm (4.5 liter/min.)
- 84995 & 84996 - 1.0 gpm (3.7 liter/min.)
- 84997 & 84998 - 0.7 gpm (2.6 liter/min.)
- 85201 & 85202 - 0.4 gpm (1.5 liter/min.)

Wetted part materials - Steel, Brass, Copper, Polyurethane, Nitrile

© Indicates Change

- ★ Repair Kit Contents
- Gland Seal Kit Contents

©

PARTS LIST

ITEM NO.	DESCRIPTION	QTY.	PART NUMBER									
			Model 84991	Model 84992	Model 84993	Model 84994	Model 84995	Model 84996	Model 84997	Model 84998	Model 85201	Model 85202
★	Repair Kits		86231	86231	86232	86232	86233	86233	86234	86234	86239	86239
●	Gland Seal Kits		85294	85294	85295	85295	85296	85296	85297	85297	85298	85298
1	Bolt Connector	1	236225	236225	242363	242363	242363	242363	242363	242363	242363	242363
2	Coupling Nut	1	237051	237051	237051	237051	237051	237051	237051	237051	237051	237051
3	Plunger Rod	1	242929	242929	242930	242930	242931	242931	242932	242932	243247	243247
4	Gland Nut	1	242933	242933	242934	242934	242935	242935	242936	242936	243246	243246
5	O-ring (polyurethane)	1	★ ●	★ ●	★ ●	★ ●	★ ●	★ ●	★ ●	★ ●	★ ●	★ ●
6	U-cup (polyurethane)	1	★ ●	★ ●	★ ●	★ ●	★ ●	★ ●	★ ●	★ ●	★ ●	★ ●
7	Packing Washer	1	★ ●	★ ●	★ ●	★ ●	★ ●	★ ●	★ ●	★ ●	★	★
8	Retaining Ring	1	★	★	★	★	★	★	★	★	★	★
9	Outlet Body	1	242216	242216	242216	242216	242216	242216	242216	242216	242216	242216
10	Priming Plug	1	16382	16382	16382	16382	16382	16382	16382	16382	16382	16382
11	Adapter	1	16381	16381	16381	16381	16381	16381	16381	16381	16381	16381
12	Gasket (copper)	2	★	★	★	★	★	★	★	★	★	★
13	Outlet Check	1	11948	11948	11948	11948	11948	11948	11948	11948	11948	11948
14	Ball	1	66285	66285	66285	66285	66285	66285	66285	66285	66285	66285
15	Ball Stop	1	57036	57036	57036	57036	57036	57036	57036	57036	57036	57036
16	Outlet Body	1	12017	12017	12017	12017	12017	12017	12017	12017	12017	12017
17	O-ring (nitrile)	1	★	★	★	★	★	★	★	★	★	★
18	Pump Tube	1	242373	242378	242373	242378	242373	242378	242373	242378	242373	242378
19	Adapter	1	----	----	----	----	----	----	13242	13242	----	----
20	Cotter Pin	2	★	★	★	★	★	★	★	★	★	★
21	Connecting Rod	1	242372	242377	242372	242377	242372	242377	242372	242377	242372	242377
22	Adapter	1	13230	13230	91917	91917	91917	91917	91916	91916	92181	92181
23	Ball	1	66728	66728	66071	66071	66071	66071	66285	66285	66030	66030
24	Ball	1	66285	66285	66030	66030	66030	66030	66007	66007	----	----
25	Pin	1	13231	13231	13237	13237	13237	13237	13240	13240	----	----
26	Bushing & Plunger	1	242545	242545	242547	242547	242548	242548	242549	242549	243245	243245
27	O-ring (nitrile)	1	★	★	★	★	★	★	★	★	★	★
28	Adapter Tube	1	242433	242433	242420	242420	242374	242374	242374	242374	242374	242374
29	Retaining Ring	1	★	★	★	★	★	★	★	★	★	★
30	Guide Washer	1	★	★	★	★	★	★	★	★	★	★
31	Bushing & Plunger	1	242546	242546	242546	242546	242546	242546	242546	242546	242546	242546
32	Cotter Pin	1	★	★	★	★	★	★	★	★	★	★
33	Retainer	1	13227	13227	13227	13227	13227	13227	13227	13227	13227	13227
34	Check	1	13229	13229	13229	13229	13229	13229	13229	13229	13229	13229
35	Check Seat	1	13228	13228	13228	13228	13228	13228	13228	13228	13228	13228
36	Priming Shovel	1	13235	13235	13235	13235	13235	13235	13235	13235	13235	13235
37	Priming Tube	1	242375	242375	242375	242375	242375	242375	242375	242375	242375	242375

RETAIN THIS INFORMATION FOR FUTURE REFERENCE

When ordering replacement parts, list: Part Number, Description, Model Number and Series Letter.

LINCOLN provides a Distributor Network that stocks equipment and replacement parts.