

OWNER/OPERATOR MANUAL

It is the responsibility of the Owner/Operator to properly use and maintain this equipment.

The Instructions and Warnings contained in this manual shall be read and understood by the Owner/Operator prior to operating this equipment.

It is the responsibility of the Owner/Operator to maintain the legibility of all Warning and Instruction labels.

The Owner/Operator shall retain this manual for future reference to important Warnings, Operating and Maintenance Instructions.



WARNING

DO NOT operate these pumps with 10" airmotor.

DO NOT exceed the stated maximum working pressure of the airmotor or the lowest rated component in your system.

DO NOT alter or modify any part of this equipment.

DO NOT operate this equipment with combustible gas.

DO NOT attempt to repair or disassemble the equipment while the system is pressurized.

TIGHTEN all fluid connections securely before using this equipment.

ALWAYS read and follow the fluid manufacturer's recommendations regarding fluid compatibility, and the use of protective clothing and equipment.

CHECK all equipment regularly and repair or replace worn or damaged parts immediately.

IMPORTANT: Failure to heed these warnings including misuse, overpressurizing, modifying parts, using incompatible chemicals and fluids, or using worn or damaged parts, may result in equipment damage and/or serious personal injury, fire, explosion, or property damage.

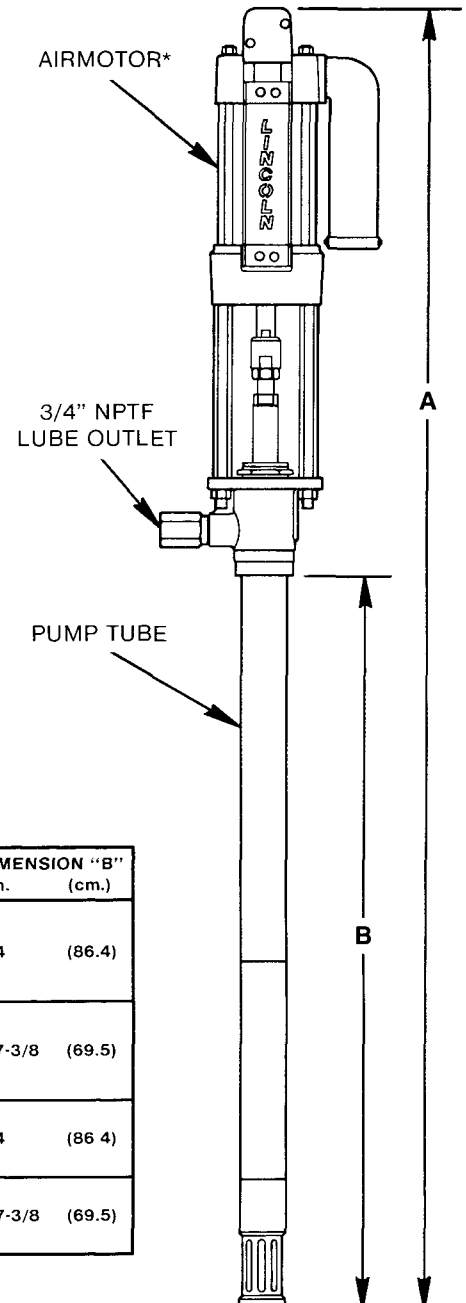

MODEL CHART

PUMP TUBE	PUMP MODEL	AIRMOTOR*	RATIO	MAXIMUM DELIVERY PRESSURE	MAXIMUM AIR PRESSURE	DIMENSION "A" in. (cm.)	DIMENSION "B" in. (cm.)
84976	2072	84808	80:1	8000 psi (552 bar)	100 psi (7 bar)	60 (152.4)	34 (86.4)
	2070	84806	44:1	4400 psi (304 bar)		60-7/8 (154.6)	
	2068	84804	22:1	4400 psi (304 bar)	200 psi (14 bar)		
	2066	84803	10:1	2000 psi (138 bar)			
84977	2079	84808	80:1	8000 psi (552 bar)	100 psi (7 bar)	53-3/8 (135.6)	27-3/8 (69.5)
	2077	84806	44:1	4400 psi (304 bar)	200 psi (14 bar)	54-1/4 (137.8)	
	2075	84804	22:1	4400 psi (304 bar)			60 (152.4)
	2073	84803	10:1	2000 psi (138 bar)			
84978	2071	84806	64:1	6400 psi (442 bar)	100 psi (7 bar)	60 (152.4)	34 (86.4)
	2069	84804	32:1	6400 psi (442 bar)	200 psi (14 bar)	60-7/8 (154.6)	
	2067	84803	15:1	3000 psi (207 bar)			
84979	2078	84806	64:1	6400 psi (442 bar)	100 psi (7 bar)	53-3/8 (135.6)	27-3/8 (69.5)
	2076	84804	32:1	6400 psi (442 bar)	200 psi (14 bar)	54-1/4 (137.8)	
	2074	84803	15:1	3000 psi (207 bar)			

* Refer to Airmotor Owner/Operator Manual, Section A50 Page 78.

ATTACHING AIRMOTOR TO PUMPTUBE

1. Tightly attach tie rods to the airmotor (use short threaded end of the tie rods).
2. Mount airmotor on top of the pump-tube outlet and tightly connect Coupling Nut (Item 2) to airmotor piston rod.
3. Hand tighten tie rods to the pumptube with four nuts supplied with airmotor.
4. Slowly cycle the pump several times, using just enough air pressure to operate the pump without stalling.
5. Stop the pump on an "up" stroke and tighten the four nuts to securely fasten the airmotor to the pumptube.

OPERATING PRECAUTIONS

- Use Lincoln replacement parts to assure compatible pressure rating.
- HEED ALL WARNINGS.
- Be sure material hoses and other components are able to withstand fluid pressures developed by this pump.
- Do not operate pump continuously at speeds in excess of 75 cycles per minute.
- Disconnect air line from pump airmotor when system sits idle for long periods of time.
- SERVICING. Before servicing or cleaning pump, or removing fluid hose or gun from a unit that has been used, be sure to disconnect air lines and carefully bleed pressure off of the system.



WARNING

PREVENT STATIC SPARKING. If static sparking occurs, fire or explosion could result. Pump, dispensing valve, and containers must be grounded when handling flammable fluids such as petroleum products, paints, lacquers, etc. and wherever discharge of static electricity is hazard.

- Check continuity (a good static wire connection) with an ohmmeter. Place one probe on one hose fitting and the other probe on other hose fitting, continuity or proper grounding through hose is good when a reading is obtained on the ohmmeter.
- PREVENT FIRES. When pumping, flushing or recirculating volatile solvents, the area must be adequately ventilated.
- Keep solvents away from heat, sparks and open flames. Keep containers closed when not in use.



CAUTION

DO NOT allow pump to operate when out of material.

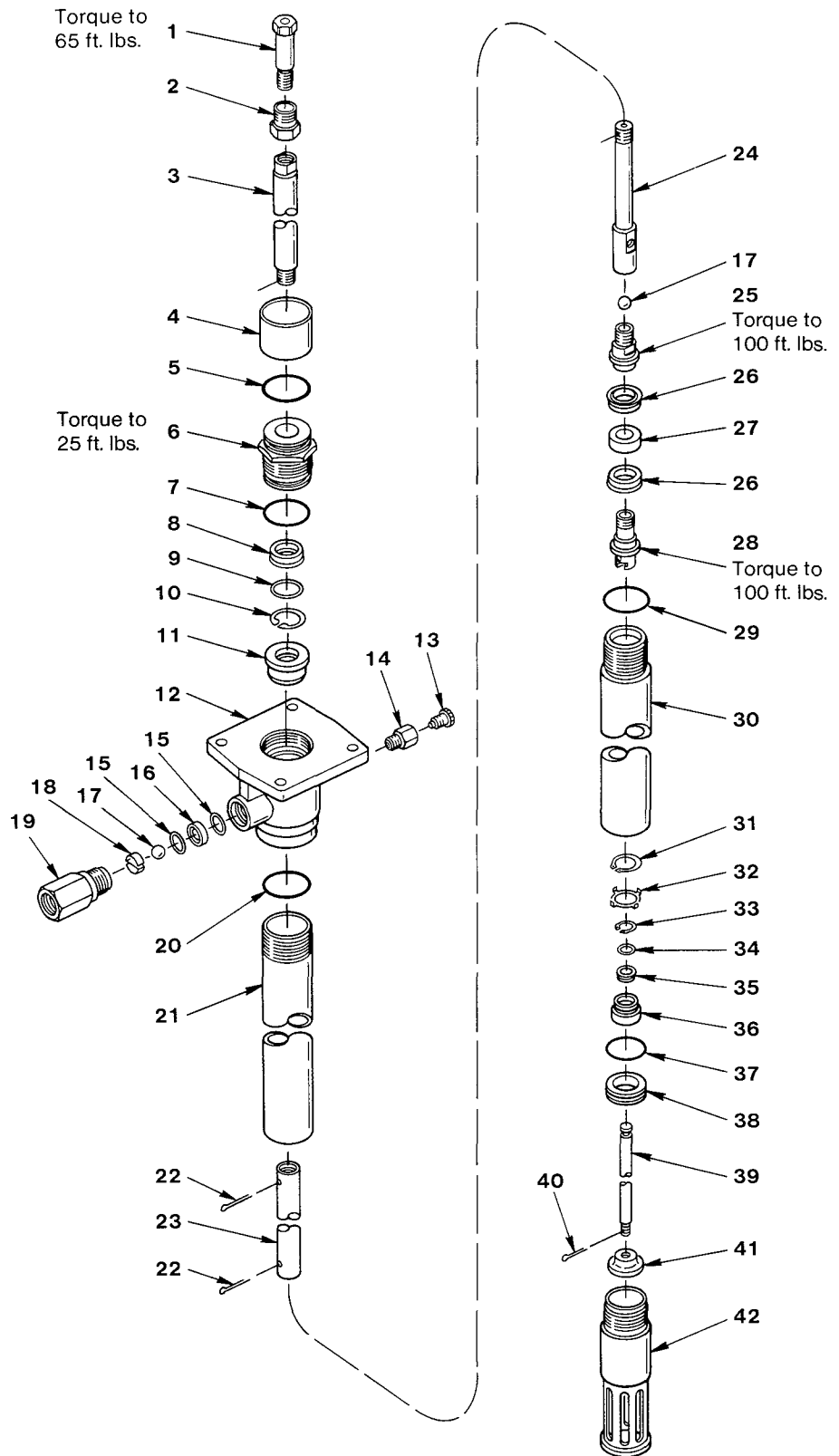

PUMP PRIMING

To begin operation, the pump has to be primed with the pumped material. The Power-Master III pump is a double acting (pumps material on "up" & "down" stroke) positive displacement reciprocating pump and as such intakes material only on the "up" stroke.

To prime pump, open output line (material valve) and slowly open air supply valve until pump starts. Allow pump to cycle very slowly until all air is

pushed out of lines and material fills up pump and lines. Close output line (material shut-off valve) - pump should stall against pressure.

Note: Pumps are factory tested with light oil and some of it is left in to protect pump parts during storage and transportation. To prevent contamination of material to be pumped, flush pump before using.

DISASSEMBLY

Tools Required

2-1/8" Dia. Strap Wrench
 Retaining Ring Pliers (External)
 Retaining Ring Pliers (Internal)
 11/16" Hex Wrench
 7/8" Hex Wrench
 13/16" Hex Wrench
 1-3/8" Hex Wrench
 2-1/4" Hex Wrench
 Pliers

Procedure

1. Remove Priming Tube (Item 42) from Adapter Tube (Item 30)
2. Remove Cotter Pin (Item 40) from from Priming Plunger (Item 39).
3. Remove Priming Shovel (Item 41) from Priming Plunger (Item 39).
4. Unscrew Adapter Tube (Item 30) from Pump Tube (Item 21) and slide off of Piston Assembly (Items 25, 27 & 28).
5. Remove Priming Plunger (Item 39) from Piston Body (Item 28).
6. Remove Check Seat (Item 38) and O-ring (Item 37) from Adapter Tube (Item 30).
7. Remove Check Assembly (Items 31, 32, 33, 34, 35, & 36) from Adapter Tube (Item 30).
8. Remove Retaining Ring (Item 31) and Guide Washer (Item 32) from Check (Item 36).
9. Remove Retaining Ring (Item 33), Packing Washer (Item 34) and U-cup Packing (Item 35) from Check (Item 36).
10. Remove Lube Cup (Item 4) from Gland Nut (Item 6).
11. Remove Bolt Connector (Item 1) from Plunger (Item 3).
12. Pull Piston Assembly (Items 25, 27 & 28) to remove Plunger (Item 3), Connecting Rod (Item 23), Adapter (Item 24) and Piston Assembly from Pump Tube (Item 21).
13. Remove Pump Tube (Item 21) from Outlet Body (Item 12).
14. Remove O-ring (Item 20) from Outlet Body (Item 12).
15. Remove Gland Nut (Item 6) from Outlet Body (Item 12).
16. Remove Sleeve (Item 11) from Outlet Body (Item 12).
17. Remove Priming Plug (Item 13) and and Adapter (Item 14) from Outlet Body (Item 12).
18. Remove Outlet Body (Item 19) from Outlet Body (Item 12).
19. Remove Ball (Item 17), Check Seat (Item 16) and Gaskets (Item 15) from Outlet Body (Item 12).
20. Remove Retaining Ring (Item 10), Packing Washer (Item 9) and U-cup Packing (Item 8) from Gland Nut (Item 6).
21. Remove Piston Adapter (Item 25) from Adapter (Item 24).
22. Remove Ball (Item 17) from Adapter (Item 24)
23. Remove Cotter Pins (Item 22) from Connecting Rod (Item 23).
24. Remove Adapter (Item 24) and Plunger (Item 3) from Connecting Rod (Item 23).
25. Unscrew Piston Adapter (Item 25) and remove Piston Collar (Item 27) from Piston Body (Item 28).
26. Remove U-cup Packings (Item 26) from Piston Adapter (Item 25) and Piston Body (Item 28)
27. To re-assemble pump, reverse disassembly procedure. (Refer to illustration for torque specifications)

TROUBLESHOOTING

Problem	Possible Cause	Solution
Pump does not operate.	Restricted or inadequate air supply. Obstructed material output.	Check air supply pressure and air hose diameter (see Airmotor manual for minimum air supply hose diameter). Check output line for restrictions.
Erratic or accelerated operation.	Pump is not primed. Insufficient material supply. Material is too heavy for priming.	Prime pump (see "Pump Priming" instructions). Refill material supply. Lower output with material valve. Increase pressure to pressure primer (if in use). Check for inlet restrictions.
Pump operates on "down" stroke only (missing "up" stroke).	Worn or damaged Piston U-cups (Item 26) or Piston Check (Items 17 & 25).	Check and replace if needed.
Pump operates on "up" stroke only (missing "down" stroke).	Worn or damaged Inlet Check (Items 36 & 38). Insufficient material supply. Pump is not intaking enough material to dispense on both strokes.	Check and replace if needed. Check inlet for restrictions. Lower output with material valve.
Pump is operating but not dispensing material.	Inlet Check (Items 36 & 38) is not seating or is damaged.	Check and replace if needed

OPTIONAL PACKING KITS (Includes Items 8, 26 & 35)

86223 Teflon Packing Kit - For Models 84976 & 84977.
86224 Teflon Packing Kit - For Models 84978 & 84979.
86225 UHMW Polyethylene Packing Kit - For Models 84976 & 84977.
86226 UHMW Polyethylene Packing Kit - For Models 84978 & 84979.
86227 Viton Packing Kit - For Models 84976 & 84977
86228 Viton Packing Kit - For Models 84978 & 84979

PUMP REPAIR KITS

86229 - Includes soft parts for Models 84976 & 84977.
86230 - Includes soft parts for Models 84978 & 84979

SPECIFICATIONS

Pump stroke - 6 in. (152 mm)

Max. recommended speed (continuous) - 75 cycles/min.

Output per cycle:

84976 & 84977 - 6.7 cu. in. (110 cc)

84978 & 84979 - 4.6 cu. in. (75 cc)

Approx. cycles per gallon (liter):

84976 & 84977 - 35 (9)

84978 & 84979 - 51 (13)

Output at 75 cycles/min.:

84976 & 84977 - 2.2 gpm (8.2 liter/min.)

84978 & 84979 - 1.5 gpm (5.7 liter/min.)

Wetted part materials - Steel, Brass, Copper, Polyurethane, Nitrile

PARTS LIST

ITEM NO.	DESCRIPTION	QTY.	PART NUMBER			
			Model 84976	Model 84977	Model 84978	Model 84979
1	Bolt Connector	1	236225	236225	236225	236225
2	Coupling Nut	1	237051	237051	237051	237051
3	Plunger	1	242914	242914	242916	242916
4	Lube Cup	1	242231	242231	242231	242231
5	O-ring (nitrile)	1	(Note #1)	(Note #1)	(Note #2)	(Note #2)
6	Gland Nut	1	242915	242915	242917	242917
7	O-ring (polyurethane)	1	(Note #1)	(Note #1)	(Note #2)	(Note #2)
8	U-cup (polyurethane)	1	(Note #1)	(Note #1)	(Note #2)	(Note #2)
9	Packing Washer	1	(Note #1)	(Note #1)	(Note #2)	(Note #2)
10	Retaining Ring	1	(Note #1)	(Note #1)	(Note #2)	(Note #2)
11	Sleeve	1	86241	86241	86240	86240
12	Outlet Body	1	242216	242216	242216	242216
13	Priming Plug	1	16382	16382	16382	16382
14	Adapter	1	16381	16381	16381	16381
15	Gasket (copper)	2	(Note #1)	(Note #1)	(Note #2)	(Note #2)
16	Outlet Check	1	11948	11948	11948	11948
17	Ball	2	66285	66285	66285	66285
18	Ball Stop	1	57036	57036	57036	57036
19	Outlet Body	1	12017	12017	12017	12017
20	O-ring (nitrile)	1	(Note #1)	(Note #1)	(Note #2)	(Note #2)
21	Pump Tube	1	242396	242401	242396	242401
22	Cotter Pin	2	(Note #1)	(Note #1)	(Note #2)	(Note #2)
23	Connecting Rod	1	242397	242402	242397	242402
24	Adapter	1	242380	242380	242380	242380
25	Piston Adapter	1	242691	242691	242698	242698
26	U-cup (polyurethane)	2	(Note #1)	(Note #1)	(Note #2)	(Note #2)
27	Piston Collar	1	242410	242410	242400	242400
28	Piston Body	1	242692	242692	242690	242690
29	O-ring (nitrile)	1	(Note #1)	(Note #1)	(Note #2)	(Note #2)
30	Adapter Tube	1	242409	242409	242398	242398
31	Retaining Ring	1	(Note #1)	(Note #1)	(Note #2)	(Note #2)
32	Guide Washer	1	(Note #1)	(Note #1)	(Note #2)	(Note #2)
33	Retaining Ring	1	(Note #1)	(Note #1)	(Note #2)	(Note #2)
34	Packing Washer	1	(Note #1)	(Note #1)	(Note #2)	(Note #2)
35	U-cup (polyurethane)	1	(Note #1)	(Note #1)	(Note #2)	(Note #2)
36	Check	1	242918	242918	242918	242918
37	O-ring (polyurethane)	1	(Note #1)	(Note #1)	(Note #2)	(Note #2)
38	Check Seat	1	242919	242919	242919	242919
39	Priming Plunger	1	242920	242920	242920	242920
40	Cotter Pin	1	(Note #1)	(Note #1)	(Note #2)	(Note #2)
41	Priming Shovel	1	13235	13235	13235	13235
42	Priming Tube	1	242375	242375	242375	242375

NOTES: 1. Included in 86229 Pump Repair Kit.
2. Included in 86230 Pump Repair Kit.

RETAIN THIS INFORMATION FOR FUTURE REFERENCE

When ordering replacement parts, list: Part Number, Description, Model Number and Series Letter.

LINCOLN provides a Distributor Network that stocks equipment and replacement parts.