

OWNERS MANUAL

IT IS THE RESPONSIBILITY OF THE OWNER AND/OR OPERATOR TO PROPERLY USE AND MAINTAIN THIS EQUIPMENT. CAREFULLY READ AND UNDERSTAND THE INSTRUCTIONS AND WARNINGS IN THIS MANUAL BEFORE OPERATING THIS EQUIPMENT.

If the operator is not fluent in English, the instructions and warnings shall be read and discussed in the operator's native language, making sure the operator comprehends the contents.

This equipment complies with OSHA Standards where applicable.

**WARNING**

DO NOT exceed the stated maximum working pressure of the airmotor or of the lowest rated component in your system.

DO NOT alter or modify any part of this equipment.

DO NOT operate this equipment with combustible gas.

DO NOT attempt to repair or disassemble the equipment while the system is pressurized.

TIGHTEN all fluid connections securely before using this equipment.

ALWAYS read and follow the fluid manufacturer's recommendations regarding fluid compatibility, and the use of protective clothing and equipment.

CHECK all equipment regularly and repair or replace worn or damaged parts immediately.

IMPORTANT: Failure to heed these warnings including misuse, overpressurizing, modifying parts, using incompatible chemicals and fluids, or using worn or damaged parts, may result in equipment damage and/or serious personal injury, fire, explosion, or property damage.

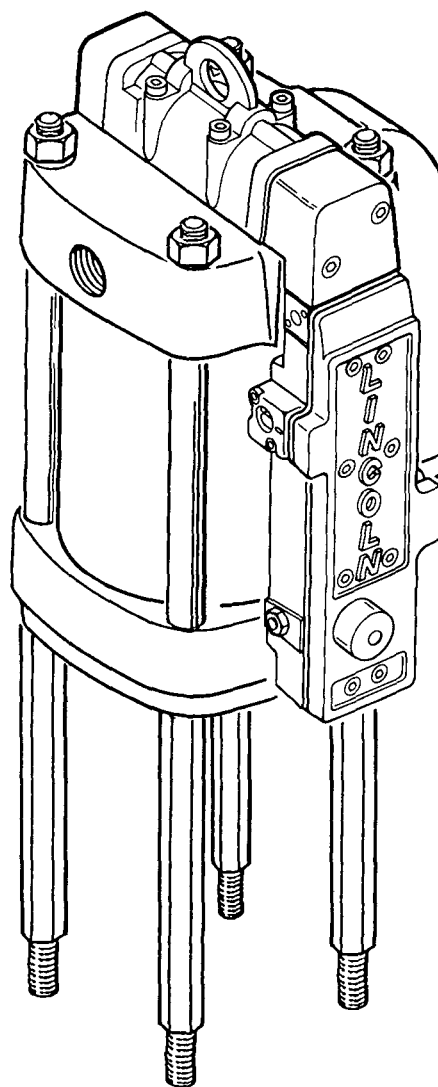

This manual contains **IMPORTANT WARNINGS** and **INSTRUCTIONS**. READ AND RETAIN FOR REFERENCE.

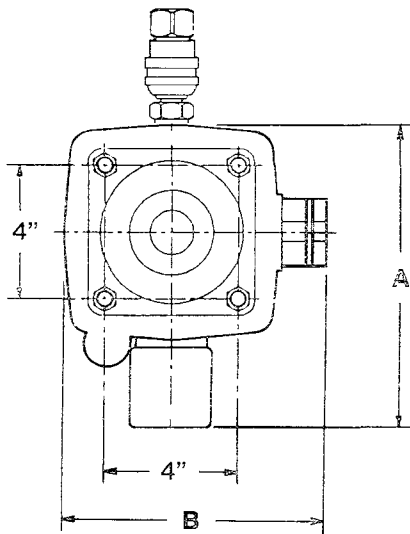
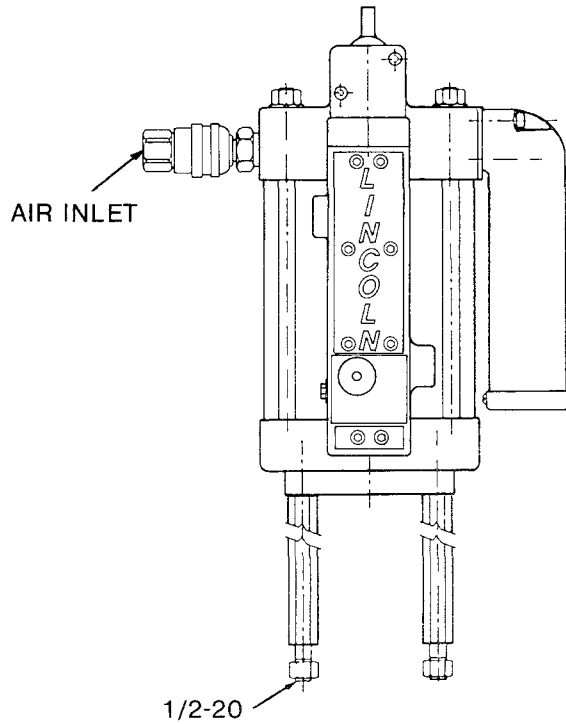
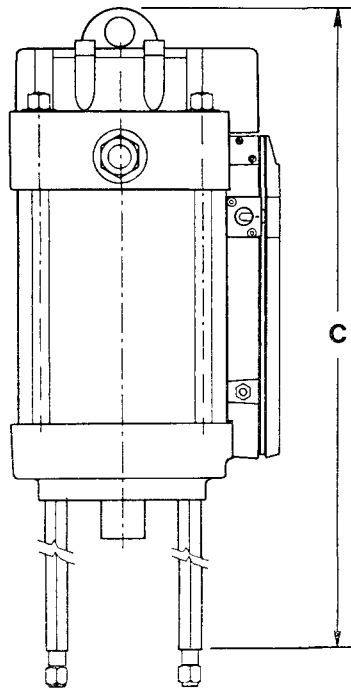

NOTE:

Use only with 6 in. (152 mm) stroke Pump Tubes. DO NOT OPERATE with air contaminated with materials not compatible with BUNA-N Seals.

SPECIFICATIONS

MODEL	CYLINDER DIAMETER IN. (MM)	EFFECTIVE PISTON AREA IN ² (CM ²)	OPERATING PRESSURE RANGE PSIG (BAR)	OPERATING TEMP. RANGE °F (°C)	MIN. I.D. OF AIR SUPPLY IN. (MM)	AIR INLET	AIR CONS. AT 75 CPM @ 100 PSIG SCFM
94808	8 (203)	50 (324)	30-100 (2-7)	30 - 200 (-34 - +93)	3/4 (20)	3/4" NPTF	160
94806	6 (152)	28 (182)	30-100 (2-7)		1/2 (12)	3/4" NPTF	105
94804	4-1/4 (108)	14 (92)	30-200 (2-14)		1/2 (12)	1/2" NPTF	65
MODEL	MAX. RECOM. SPEED CPM	STROKE LENGTH IN. (MM)	WEIGHT LB. (KG)	SEALS MATERIAL	DIM. A IN. (MM)	DIM. B IN. (MM)	DIM. C IN. (MM)
94808	75	6 (152)	46.5 (21)	BUNA-N	11-1/4 (286)	11-1/16 (280)	22-3/4 (577)
94806			33 (15)	and	9-1/4 (235)	9-1/4 (197)	22-3/4 (577)
94804			22 (10)	*TEFLON®	7-1/2 (191)	7-1/4 (152)	23-5/8 (599)

*TEFLON® Seals used with Power Valve Spool (Item 13) and Relay Valve (Item 17).

SERVICE ASSEMBLIES & KITS

To reduce down-time and take advantage of the modular design of the airmotor, Lincoln recommends using the following Service Assemblies for repair of the airmotor. After removal, the faulty assembly can then be repaired using the corresponding Soft Parts Kit.

1. Air Brake® Subassembly

P/N 84988

Note: Will not fit 84803
3" Series III Airmotor.

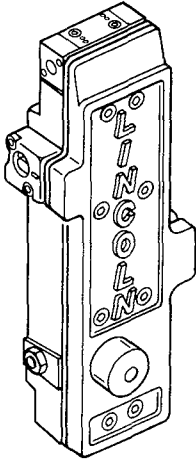

2. Soft Parts Kit P/N 84967 for repair of Air Brake® Subassembly (See Parts List for contents.)

3. Relay Valve P/N 242787

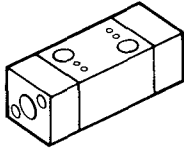

4. Signal Valve Cap Kit

P/N 243853

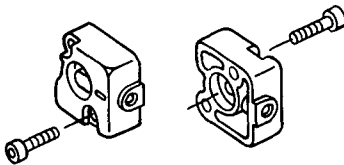

5. Air Signal Valve P/N 241768

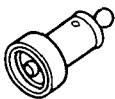

6. Trip Indicator P/N 243852

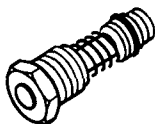

7. Stop Valve Repair Kit

P/N 244091

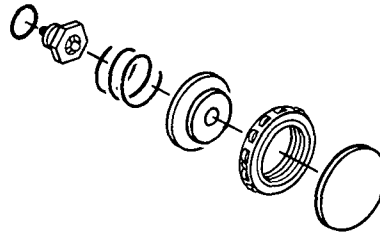

8. Air Pump Repair Kit

P/N 244092

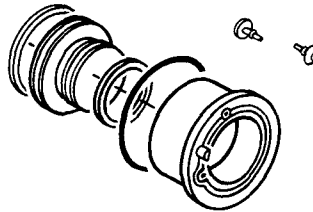

9. Bleed Assembly P/N 243854

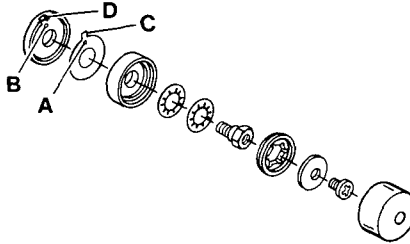

10. Gasket and Air Filter Kit

P/N 244089 (Items 40, 51 & 53)

11. Gasket Plate with Check Valves

P/N 244093 (Items 52 & 63)

12. Upper Body

P/N 243855 (Item 50)

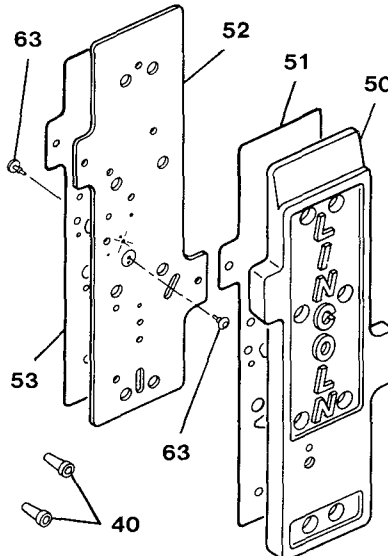

13. Complete Air Brake® Repair Kit

P/N 243851

(Includes all kits listed in #4 thru #11)

14. Cylinder Tube Soft Parts Kit

(Includes "O"-rings, piston seal, etc.)

P/N 84791 (8" Airmotor)

P/N 84792 (6" Airmotor)

P/N 84793 (4-1/4" Airmotor)

15. Muffler with Gasket P/N 242788

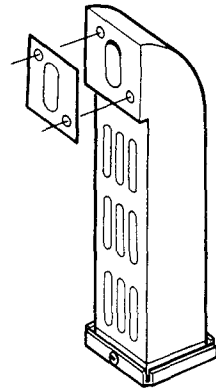

16. Muffler Element Kit P/N 84939 for repair of Muffler listed above. (Includes element, felts and gasket.)

17. Power Valve Subassembly

P/N 244804 (8" Airmotor)

P/N 244806 (6" Airmotor)

P/N 244808 (4-1/4" Airmotor)

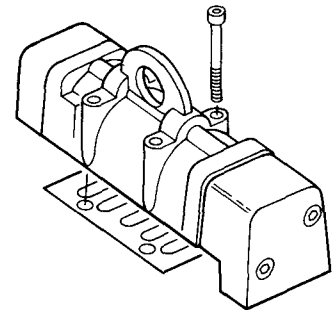

18. Soft Parts Kit P/N 84968 for repair of Power Valve Subassemblies listed above.

19. Power Valve Spool & Body

P/N 244802

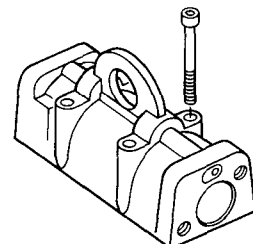

IMPORTANT: When replacing soft parts, replace all parts included in the soft parts kit.

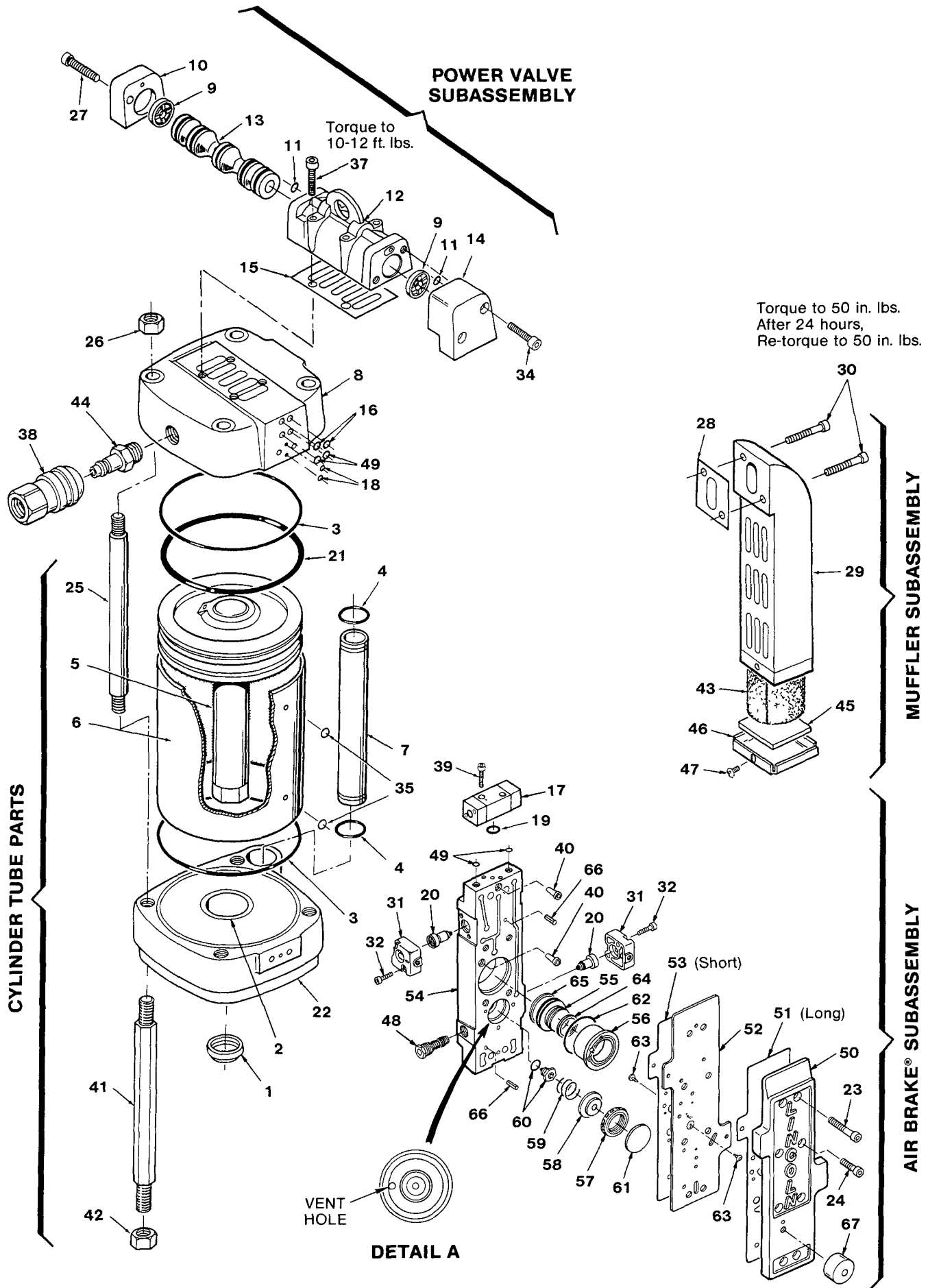



WARNING

ALWAYS check equipment for proper operation before each use, making sure safety devices are in place and operating properly. **DO NOT** alter or modify any part of the equipment as this may cause a malfunction and result in serious bodily injury.

BEFORE CONNECTING AIRMOTOR TO AIR LINE

LINCOLN SERIES III AIRMOTORS are fully pneumatic and require a minimum specified size of air supply hose for proper operation. Check specification for minimum I.D. of the air supply hose and select corresponding sizes of air controls and accessories for non-restrictive air flow. Lincoln filter, regulator with gauge and lubricators are available as combination units (FRL).

For 3/8" air line - Model 83387-6
For 1/2" air line - Model 83387-8
For 3/4" air line - Model 83387-12

If quick disconnect coupling should be used, install supplied coupler to insure proper airmotor operation.

NOTE: Whenever flammable materials are pumped, ground Airmotor according to Local Codes.

OPERATING PRECAUTIONS

Use Lincoln replacement parts to assure compatible pressure rating.

Heed ALL warnings.

DO NOT OPERATE Airmotor continuously at speeds exceeding 75 cycles per minute.

DO NOT OPERATE Airmotor in excess of recommended pressure range.

Disconnect air line and relieve (vent) pressure when Airmotor sits idle for long periods of time and before servicing.



WARNING

ALWAYS read and follow the fluid and solvent manufacturer's recommendations regarding the use of protective clothing and equipment.



WARNING

To reduce the risk of serious bodily injury or property damage. **NEVER** exceed the maximum air or fluid working pressure of the lowest rated system component.

ATTACHING AIRMOTOR TO PUMPTUBE

1. Tightly attach the tie rods (Item 41) to the Airmotor lower casting. Use short threaded end of tie rods.
2. Mount Airmotor on top of pump tube outlet and tightly connect pump tube coupling nut to Airmotor Piston Rod (Item 5).
3. Hand tighten tie rods to the pump tube with four nuts (Item 42) supplied with Airmotor.
4. Connect air supply and slowly cycle pump several times using only enough air pressure to operate pump without stalling.
5. **STOP** pump on "UP" stroke and tighten four nuts to securely fasten Airmotor to pump tube.

SERVICE AND DISASSEMBLY PROCEDURE



WARNING

Always disconnect air supply to Airmotor and relieve pressure before checking, servicing, or repairing any part of Airmotor.

TOOLS REQUIRED

1. 7/64 (.109) Hex Wrench
2. 5/32 (.156) Hex Wrench
3. 3/16 (.189) Hex Wrench
4. 1/8 (.125) Hex Wrench
5. 3/4 (.750) Open End Wrench (for 6" Airmotor)
6. 15/16 (.937) Open End Wrench (for 8" Airmotor)
7. 1/2 (.500) Open End Wrench (for 4-1/4" Airmotor)
8. 1/2 (.500) Box End Wrench.
9. Pliers
10. 0-100 in. lb. Torque Wrench.

The modular design of the Airmotor and accessibility of vital operation parts make service available without taking Airmotor out of line or without complete disassembly.

Power Valve

1. Remove four screws (Items 27 & 34) with 3/16" hex wrench (2 on each side).
2. Remove End Caps (Items 10 & 14).
3. Push out Valve Spool (Item 13).
4. Remove Spool Bumpers (Item 9) (One from each end).

5. Remove "O" Ring (Item 11) (One from each end of valve body).
6. Remove four Screws (Item 37) with 3/16" hex wrench and lift valve body (Item 12).
7. Remove Gasket (Item 15) to complete valve disassembly.
8. To REASSEMBLE, REVERSE procedure.

Air Brake® Subassembly

1. Remove four Screws (Item 23) (two on each end) with 3/16" hex wrench and pull out Air Brake® Subassembly.
2. Remove two Screws (Item 39), with 7/64" hex wrench and lift out Valve Body (Item 17).
3. Remove four Screws (Item 32) (two on each side of Air Brake®) with 1/8" hex wrench and remove Signal Valve Caps (Item 31) and Air Signal Valves (Item 20).
4. Remove four Screws (Item 24) with 3/16" hex wrench and lift off Upper Body (Item 50) and Upper Gasket (Item 51).
5. Remove Gasket Plate (Item 52) and Lower Gasket (Item 53).
6. Remove Air Filter (Item 40) in two locations.
7. Remove Pump Sleeve (Item 56) and Piston (Item 55).
8. Remove Diaphragm Seal and Retainer, Diaphragm, Spring and Stop Valve Assembly (Items 61, 57, 58, 59 & 60).
9. Remove cover from Bleed Assembly (Item 67) and remove lock screw. Using 1/2" box end wrench, remove bleed valve bolt and remaining parts.

10. Remove Trip Indicator (Item 48).
11. To REASSEMBLE, REVERSE procedure, insuring that:
 - a. Upper and Lower Gaskets (Items 51 & 53) are well oiled with 10 wt. motor oil.
 - b. Assembly Screws (Items 23 & 24) are torqued to 65 to 70 in. lbs.

Cylinder Tube and Muffler

1. Remove Air Brake® Subassembly (See previous instructions).
2. Remove two Screws (Item 30) with 3/16" hex wrench and pull off Muffler (Item 29).
3. Remove Gasket (Item 28).
4. Remove four Nuts (Item 26) with open end wrench.
5. Lift upward and remove Upper Casting (Item 8).
6. Remove four Tie Rods (Item 25).
7. Remove Air Tube (Item 7).
8. Lift upward and remove Cylinder Tube (Item 6).
9. Remove Piston and Piston Rod (Item 5).
10. Remove four Connecting Rods (Item 41) with open end wrench.
11. To REASSEMBLE, REVERSE procedure.

NOTE: Align two holes on the Cylinder Tube (Item 6) with two holes on the Air Brake® Subassembly before tightening Tie Rods (Items 25) so that proper seal with "O"-rings is achieved.

PARTS LIST

Item No.	Description	(Qty.)	Part Number		
			Model 94808 (8" Dia.)	Model 94806 (6" Dia.)	Model 94804 (4 1/4" Dia.)
1	"U" Cup (Buna-N)	(1)	(Note #1)	(Note #2)	(Note #3)
2	Rod Bearing	(1)	241732	241732	241733
3	Seal, Cylinder (Buna-N)	(2)	(Note #1)	(Note #2)	(Note #3)
4	"O"-ring (Buna-N)	(2)	(Note #1)	(Note #2)	(Note #3)
5	Piston Rod Assembly	(1)	241740	241741	241742
6	Cylinder Tube	(1)	241744	241745	241746
7	Air Tube	(1)	241748	241748	241749
8	Upper Casting	(1)	241750	241751	241752
9	Bumper, Valve	(2)	(Note #5)	(Note #5)	(Note #5)
10	Cap, Valve	(1)	241755	241755	241755
11	"O"-ring (Buna-N)	(2)	(Note #5)	(Note #5)	(Note #5)
12	Body, Valve	(1)	244658	244658	244658
13	Spool, Valve	(1)	241758	241758	241758
14	Cap, Valve	(1)	241759	241760	241761
15	Gasket	(1)	(Note #5)	(Note #5)	(Note #5)
16	"O"-ring (Buna-N)	(2)	(Note #5)	(Note #5)	(Note #5)
17	Relay Valve	(1)	242787	242787	242787
18	"O"-ring (Buna-N)	(3)	(Note #6)	(Note #6)	(Note #6)
19	"O"-ring (Buna-N)	(1)	(Note #6)	(Note #6)	(Note #6)
20	Air Signal Valve	(2)	241768	241768	241768
21	"O"-ring, Piston (Buna-N)	(1)	(Note #1)	(Note #2)	-----
22	Lower Casting	(1)	241773	241774	241775
23	Screw (1/4-20 x 1-1/2")	(4)	50051	50051	50051
24	Screw (1/4-20 x 7/8")	(4)	50850	50850	50850
25	Tie Rod	(4)	241766	241779	241767
26	Nut	(4)	51018	51007	51001
27	Screw	(2)	244995	244995	244995
28	Gasket	(1)	(Note #4)	(Note #4)	(Note #4)
29	Muffler Body	(1)	241021	241021	241021
30	Screw (1/4-20 x 1-1/2")	(2)	50051	50051	50051
31	Signal Valve Cap	(2)	(Note #8)	(Note #8)	(Note #8)
32	Screw	(4)	(Note #8)	(Note #8)	(Note #8)
33	Seal, Piston	(2)	-----	-----	(Note #3)
34	Screw	(2)	244993	241783	244994
35	"O"-ring (Buna-N)	(2)	(Note #6)	(Note #6)	(Note #6)
36	Adapter	(1)	-----	-----	241789
37	Screw (1/4-20 x 2-1/4")	(4)	244975	244975	244975
38	Coupler	(1)	655012	655012	655008
39	Screw (6-32)	(2)	50816	50816	50816
40	Air Filter	(2)	(Note #7)	(Note #7)	(Note #7)
41	Tie Rod	(4)	241023	241023	241023
42	Nut (1/2-20)	(4)	236203	236203	236203
43	Muffler Element	(1)	(Note #4)	(Note #4)	(Note #4)
44	Nipple	(1)	653112	653112	653112
45	End Element	(1)	(Note #4)	(Note #4)	(Note #4)
46	Muffler Plate	(1)	241027	241027	241027
47	Screw, Self Tapping (10-32)	(2)	66962	66962	66962
48	Trip Indicator	(1)	243852	243852	243852
49	"O"-ring (Buna-N)	(4)	(Note #6)	(Note #6)	(Note #6)
50	Upper Body	(1)	243855	243855	243855
51	Upper Gasket (Nitrile)	(1)	(Note #7)	(Note #7)	(Note #7)
52	Gasket Plate	(1)	(Note #9)	(Note #9)	(Note #9)
53	Lower Gasket (Nitrile)	(1)	(Note #7)	(Note #7)	(Note #7)
54	Lower Body	(1)	N/A	N/A	N/A
55	Piston	(1)	(Note #10)	(Note #10)	(Note #10)
56	Pump Sleeve	(1)	(Note #10)	(Note #10)	(Note #10)
57	Diaphragm Retainer	(1)	(Note #11)	(Note #11)	(Note #11)
58	Diaphragm	(1)	(Note #11)	(Note #11)	(Note #11)
59	Spring	(1)	(Note #11)	(Note #11)	(Note #11)
60	Stop Valve Assembly	(1)	(Note #11)	(Note #11)	(Note #11)
61	Diaphragm Seal	(1)	(Note #11)	(Note #11)	(Note #11)
62	"O"-ring (Buna-N)	(1)	(Note #10)	(Note #10)	(Note #10)
63	Umbrella Seal (Nitrile)	(2)	(Note #9 & 10)	(Note #9 & 10)	(Note #9 & 10)
64	Quad Ring (Buna-N)	(1)	(Note #10)	(Note #10)	(Note #10)
65	Quad Ring (Buna-N)	(1)	(Note #10)	(Note #10)	(Note #10)
66	Spring Pin	(2)	243614	243614	243614
67	Bleed Assembly	(1)	243854	243854	243854

- NOTES:**
- Included in 84791 Cylinder Tube Soft Parts Kit for Model 94808 (8" Armotor)
 - Included in 84792 Cylinder Tube Soft Parts Kit for Model 94806 (6" Armotor)
 - Included in 84793 Cylinder Tube Soft Parts Kit for Model 94804 (4-1/4" Armotor)
 - Included in 84939 Muffler Element Kit
 - Included in 84968 Soft Parts Kit for Power Valve Subassembly
 - Included in 84967 Soft Parts Kit for Air Brake® Subassembly.
 - Included in 244089 Gasket and Air Filter Kit.
 - Included in 243853 Signal Valve Cap Kit
 - Included in 244093 Gasket Plate with Check Valves.
 - Included in 244092 Air Pump Repair Kit.
 - Included in 244091 Stop Valve Repair Kit

N/A - Not Available

© Indicates Change

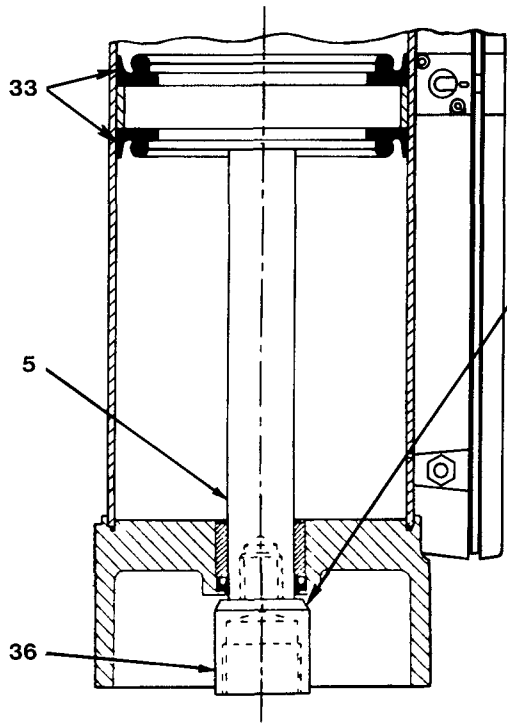

Assemble Adapter to Piston Rod
Using Loctite #242 Blue on threads.
Torque to 60-65 Ft. Lbs.

MODEL 94804

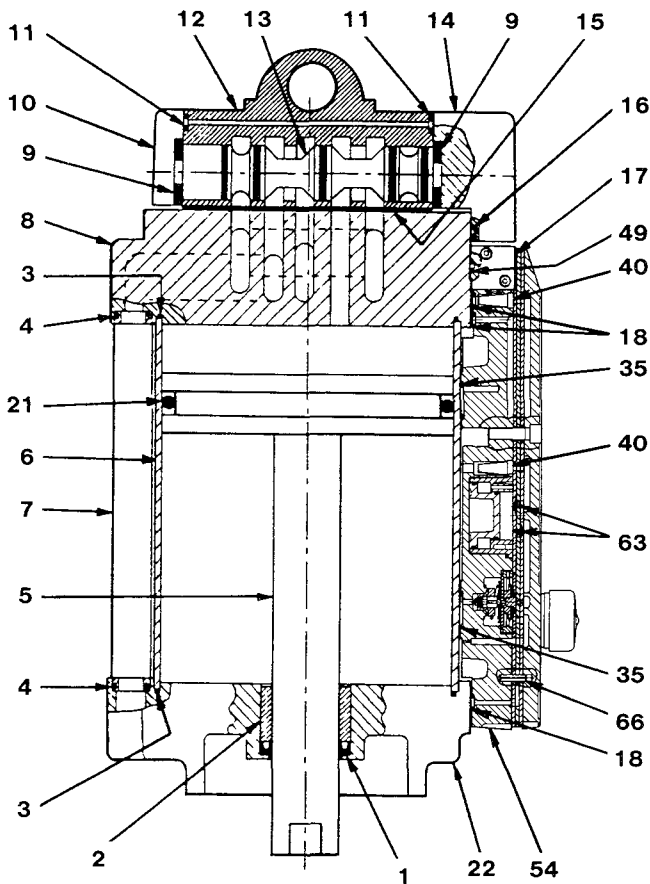

MODELS 94806 and 94808

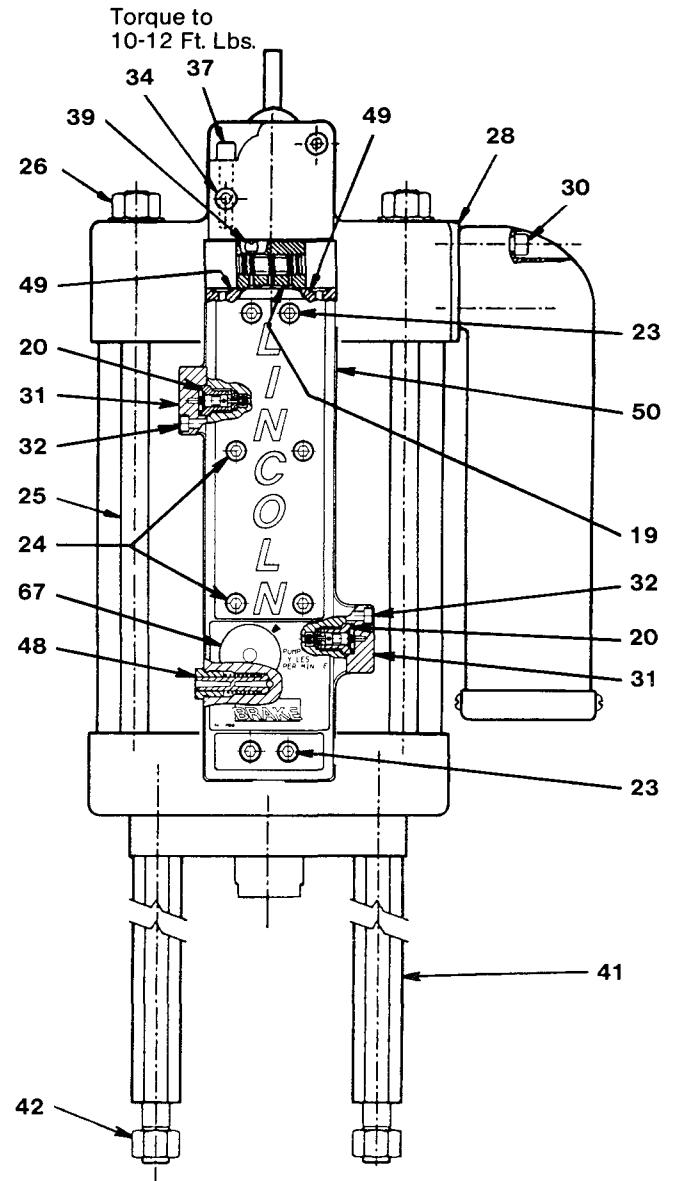

Torque to
10-12 Ft. Lbs.

SETTING THE AIR BRAKE® TRIP SPEED

1. Determine the **maximum** speed the Airmotor will need to run.
2. Add 15 cycles per minute to this maximum required speed.
3. Loosen the lock screw.
4. Rotate the bleed knob to the correct setting as follows:

Maximum Airmotor Speed	Bleed Knob Setting
0-20 cycles/min.	Low
20-50 cycles/min.	Medium
50-75 cycles/min	High

5. Turn lock screw until it contacts spring washer, then tighten additional 1/2 turn.
6. Test unit in normal use to insure setting is not too low. If Air Brake® stops Airmotor during normal operation, increase the setting.

NOTE: Air Brake® is disabled when bleed knob is set on the run setting.

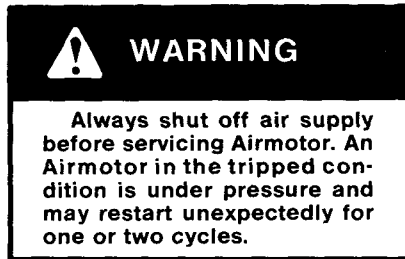

AIR BRAKE® RESETTING INSTRUCTIONS

If the Airmotor runs faster than the preset speed, the Air Brake® will stop the airmotor with the pump plunger in the down position. The Trip Indicator piston extends to indicate that the Air Brake® has been triggered and is preventing Airmotor operation.

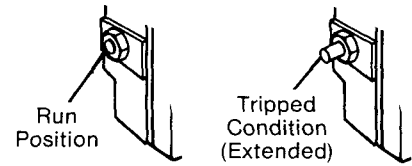

To reset the Air Brake®:

1. Shut off air supply to Airmotor.
2. Press flush reset button with a screwdriver (located on right side of Relay Valve - Item 17) until Air Brake® shifts and indicator button retracts.

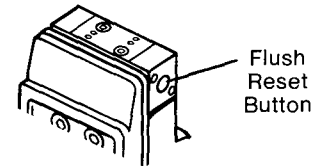

3. Wait two full minutes to insure all residual pressure vents off.
4. Turn on air supply. Airmotor will now restart.

TROUBLESHOOTING

Problem	Possible Cause	Solution
Airmotor does not operate, air escaping from exhaust.	Restricted or inadequate air supply.	Check air supply and adjust to minimum recommended level. Check air supply hose diameter and change it to minimum recommended size (see specifications). Check size of FRL and quick disconnect coupling. Replace if too small or restricted.
Erratic or accelerated operation with short stroking.	Dirty or damaged Relay Valve (Item 17) or Air Signal Valve (Item 20).	Check valves and clean if necessary. Replace any damaged or worn parts.
Air Brake® "trips" off even though airmotor is running below set trip speed. (Runs three strokes or more before stopping.)	Bleed groove clogged in Bleed Assembly (Item 67).	Remove bleed assembly and check bleed groove for foreign matter. If found, disassemble entire Air Brake® for cleaning and replace air line filter.
Air Brake® "trips" very quickly after airmotor is started (within 3 strokes), even though airmotor is running below set trip speed.	Leaking Diaphragm (Item 58). Leaking Upper Gasket (Item 51). Upper piston Quad Ring (Item 64) is leaking. Bleed Hole (A) in clear washer not aligned with Bleed Hole (B) in bleed base.	Replace diaphragm. Replace Upper and Lower Gaskets (Items 51 & 53). Replace quad ring. Align Tab (C) of clear washer to Slot (D) in bleed base. (See illustration 9 in Service Assemblies and Kits.)
Air Brake® "trips" at proper speed (indicated by the sound of air surging into diaphragm chamber), but airmotor does not stop.	Stop valve vent hole in Lower Body (Item 54) is clogged. (See Detail A, page 4.) Stop Valve (Item 60) is damaged.	Unclog vent hole in lower body. Check stop valve and replace if worn or damaged.
Air Brake® will not trip even though airmotor has been running above the trip speed for more than 1 minute.	Discharge Umbrella Seal (Item 63) is not closing properly. Diaphragm (Item 58) is not properly installed, or is leaking due to damage. Leaking Upper Gasket (Item 51) or Lower Gasket (Item 53). Stuck metering Pump Piston (Item 55). Inlet Air Filter (Item 40) is completely or partially clogged.	Inspect and replace both umbrella seals if damaged. Reinstall diaphragm properly or replace if damaged. Disassemble Air Brake® and re-assemble with new gaskets. Increase air pressure to 100 PSI and try again. If this fails, replace piston and pump sleeve, including all rubber parts (Items 55, 56, 62, 64 & 65). Clean or replace inlet air filter.

RETAIN THIS INFORMATION FOR FUTURE REFERENCE

When ordering replacement parts, list: Part Number, Description, Model Number and Series Letter.

LINCOLN provides a Distributor Network that stocks equipment and replacement parts.