



Models 94804, 94806, 94808, 94810
4¼, 6, 8 & 10 IN. AIRMOTORS
WITH AIR BRAKE®
Series "A"

OWNERS MANUAL

IT IS THE RESPONSIBILITY OF THE OWNER AND/OR OPERATOR TO PROPERLY USE AND MAINTAIN THIS EQUIPMENT. CAREFULLY READ AND UNDERSTAND THE INSTRUCTIONS AND WARNINGS IN THIS MANUAL BEFORE OPERATING THIS EQUIPMENT.

If the operator is not fluent in English, the instructions and warnings shall be read and discussed in the operator's native language, making sure the operator comprehends the contents.

This equipment complies with OSHA Standards where applicable.

WARNING

DO NOT exceed the stated maximum working pressure of the airmotor or of the lowest rated component in your system.

DO NOT alter or modify any part of this equipment.

DO NOT operate this equipment with combustible gas.

DO NOT attempt to repair or disassemble the equipment while the system is pressurized.

TIGHTEN all fluid connections securely before using this equipment.

ALWAYS read and follow the fluid manufacturer's recommendations regarding fluid compatibility, and the use of protective clothing and equipment.

CHECK all equipment regularly and repair or replace worn or damaged parts immediately.

IMPORTANT: Failure to heed these warnings including misuse, overpressurizing, modifying parts, using incompatible chemicals and fluids, or using worn or damaged parts, may result in equipment damage and/or serious personal injury, fire, explosion, or property damage.

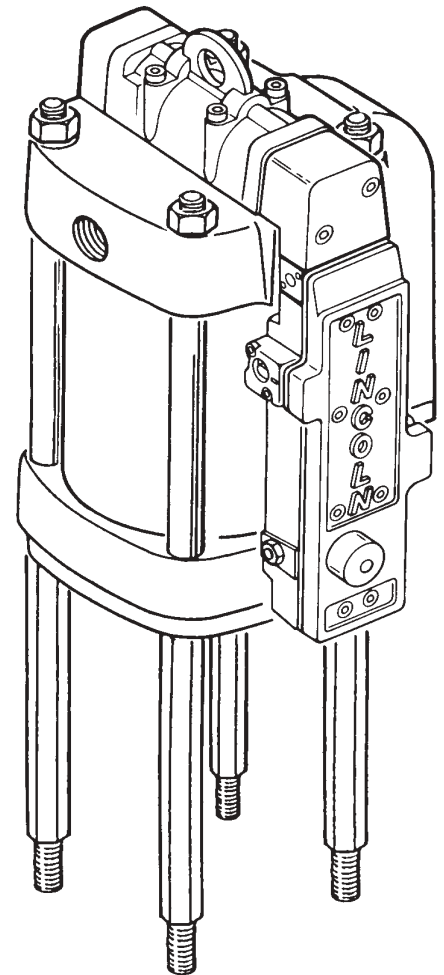

This manual contains **IMPORTANT WARNINGS** and **INSTRUCTIONS**. READ AND RETAIN FOR REFERENCE.



One Lincoln Way
St. Louis, Missouri 63120-1578
(314) 679-4200

Copyright 2003
Printed in U.S.A.

Section - **A50**
Page - **84H**

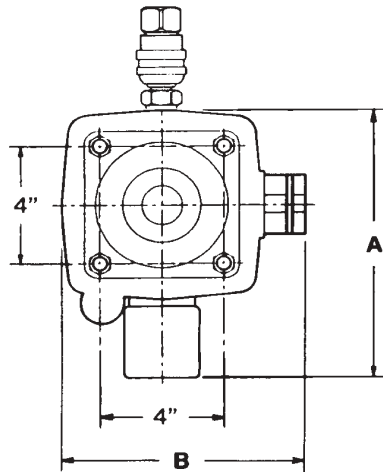
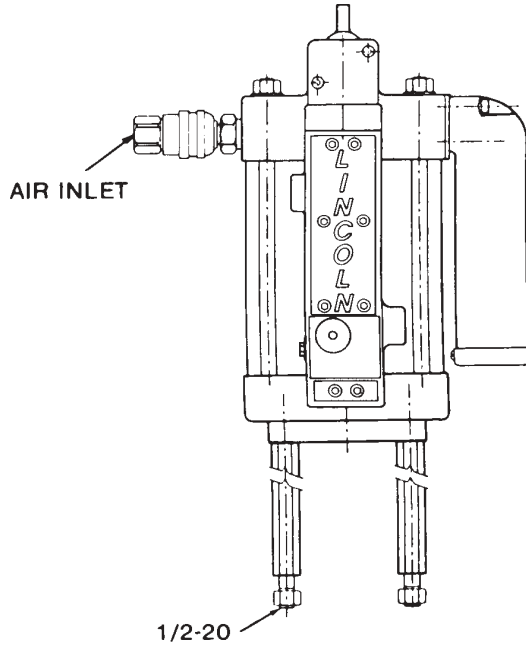
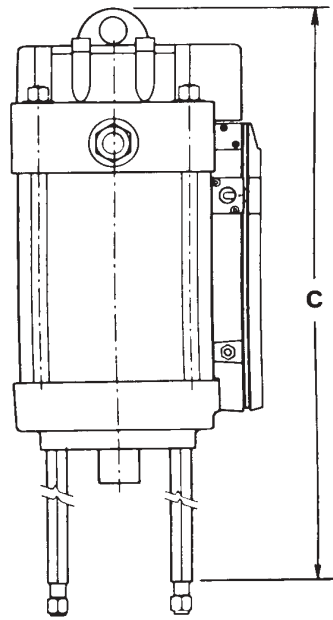

NOTE:
Use only with 6 in. (152 mm) stroke
Pump Tubes. DO NOT OPERATE
with air contaminated with materials
not compatible with BUNA-N seals.

SPECIFICATIONS

MODEL	CYLINDER DIAMETER IN. (MM)	EFFECTIVE PISTON AREA IN ² (CM ²)	OPERATING PRESSURE RANGE PSIG (BAR)	OPERATING TEMP. RANGE °C (°F)	MIN. I.D. OF AIR SUPPLY IN. (MM)	AIR INLET	AIR CONS. @ 100 PSIG (7 BAR) SCF/CYCLE (L(N)/CYCLE)
94810	10 (254)	78 (506)	30-100 (2-7)		3/4 (20)	3/4" NPTF	3.6 (103)
94808	8 (203)	50 (324)	30-100 (2-7)	-30 - +200	3/4 (20)	3/4" NPTF	2.6 (75)
94806	6 (152)	28 (182)	30-100 (2-7)	(-34 - +93)	1/2 (12)	3/4" NPTF	1.6 (46)
94804	4 1/4 (108)	14 (92)	30-200 (2-14)		1/2 (12)	1/2" NPTF	1.1 (32)
MODEL	MAX. RECOM. SPEED CPM	STROKE LENGTH IN. (MM)	WEIGHT LB. (KG)	SEALS MATERIAL	DIM. A IN. (MM)	DIM. B IN. (MM)	DIM. C IN. (MM)
94810			62 (28.1)		13-1/4 (337)	11-5/8 (295)	22-3/4 (577)
94808			47 (21.2)	BUNA-N	11-1/4 (286)	9-9/16 (243)	22-3/4 (577)
94806	75	6 (152)	34 (15.5)	and	9-1/4 (235)	9-1/4 (235)	22-3/4 (577)
94804			26 (11.7)	*TEFLON	7-1/2 (191)	7-1/4 (184)	23-5/8 (599)

*TEFLON® Seals used with Power Valve Spool (Item 13) and Relay Valve (Item 17).

SERVICE ASSEMBLIES & KITS

To reduce down-time and take advantage of the modular design of the airmotor, Lincoln recommends using the following Service Assemblies for repair of the airmotor. After removal, the faulty assembly can then be repaired using the corresponding Soft Parts Kit.

1. Air Brake® Subassembly

P/N 84988

Note: Will not fit 84803
3" Series III Airmotor.

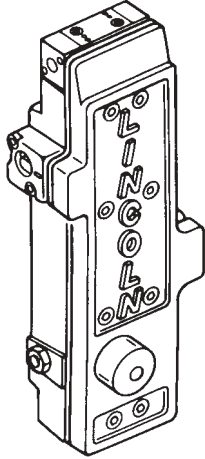

2. Soft Parts Kit P/N 84967 for repair of Air Brake® Subassembly.
(See Parts List for contents.)

3. Relay Valve P/N 242787

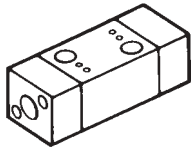

4. Signal Valve Cap Kit

P/N 243853

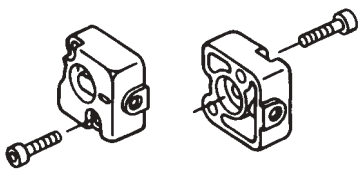

5. Air Signal Valve P/N 241768

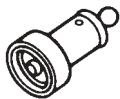

6. Trip Indicator P/N 243852



7. Stop Valve Repair Kit

P/N 244091

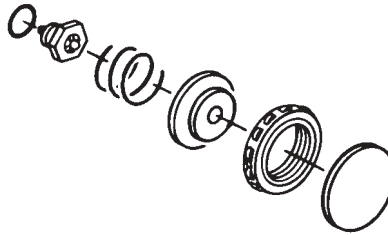

8. Air Pump Repair Kit

P/N 244092

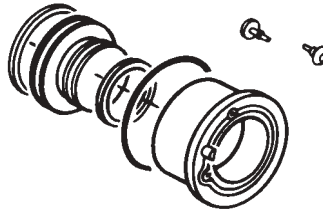

9. Bleed Assembly P/N 243854

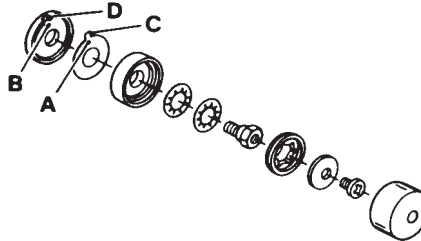

10. Gasket and Air Filter Kit

P/N 244089 (Items 40, 51 & 53)

11. Gasket Plate with Check Valves

P/N 244093 (Items 52 & 63)

12. Upper Body

P/N 243855 (Item 50)

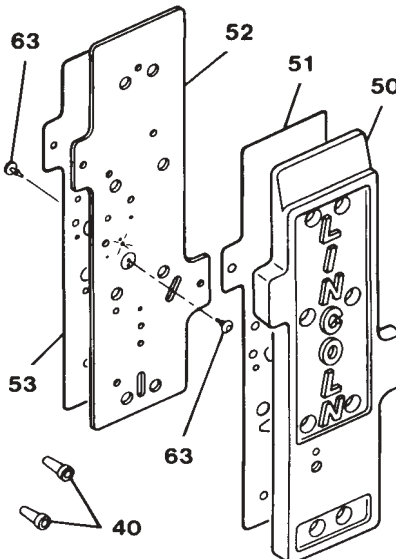

13. Complete Air Brake® Repair Kit

P/N 243851

(Includes all kits listed in #4 thru #11)

14. Cylinder Tube Soft Parts Kit

(Includes "O"-rings, piston seal, etc.)

P/N 84789 (10" Airmotor)

P/N 84791 (8" Airmotor)

P/N 84792 (6" Airmotor)

P/N 84793 (4-1/4" Airmotor)

15. Muffler with Gasket P/N 242788

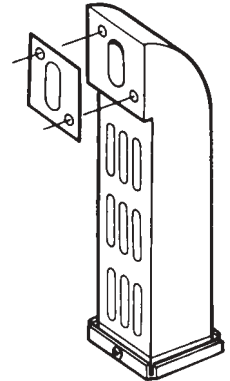

16. Muffler Element Kit P/N 84939

for repair of Muffler listed above.
(Includes element, felts and gasket.)

17. Power Valve Subassembly

P/N 244800 (10" Airmotor)

P/N 244804 (8" Airmotor)

P/N 244806 (6" Airmotor)

P/N 244808 (4-1/4" Airmotor)

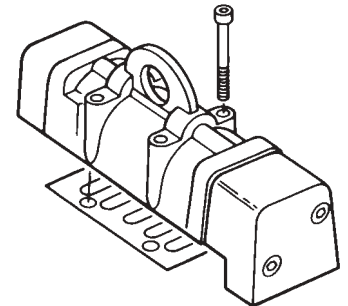

18. Soft Parts Kit P/N 84968 for repair of Power Valve Subassemblies listed above.

19. Power Valve Spool & Body

P/N 244802

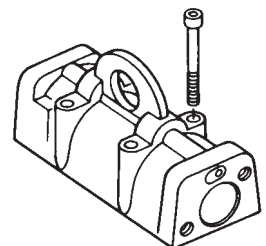

IMPORTANT: When replacing soft parts, replace all parts included in the soft parts kit.



WARNING

ALWAYS check equipment for proper operation before each use, making sure safety devices are in place and operating properly. DO NOT alter or modify any part of the equipment as this may cause a malfunction and result in serious bodily injury.

BEFORE CONNECTING AIRMOTOR TO AIR LINE

LINCOLN SERIES III AIRMOTORS are fully pneumatic and require a minimum specified size of air supply hose for proper operation. Check specification for minimum ID. of the air supply hose and select corresponding sizes of air controls and accessories for non-restrictive air flow. Lincoln filter, regulator with gauge and lubricators are available as combination units (FRL).

For 3/8" air line - Model 85387-6
For 1/2" air line - Model 85387-8
For 3/4" air line - Model 85387-12

If quick disconnect coupling should be used, install supplied coupler to insure proper airmotor operation.

SERVICE AND DISASSEMBLY PROCEDURE



WARNING

Always disconnect air supply to Airmotor and relieve pressure before checking, servicing, or repairing any part of Airmotor.

TOOLS REQUIRED

1. 7/64 (.109) Hex Wrench
2. 5/32 (.156) Hex Wrench
3. 3/16 (.189) Hex Wrench
4. 1/8 (.125) Hex Wrench
5. 3/4 (.750) Open End Wrench (for 6" Airmotor)
6. 15/16 (.937) Open End Wrench (for 8" Airmotor)
7. 1/2" (.500) Open End Wrench (for 4-1/4" and 3" Airmotor)
8. 1-1/8" (1.125) Open End Wrench (for 10" Airmotor)
9. 1/2" (.500) Box End Wrench
10. Pliers
11. 0-100 in. lb. Torque Wrench
12. 0 - 75 Ft. lb. Torque Wrench.

The modular design of the Airmotor and accessibility of vital operation parts make service available without taking Airmotor out of line or without complete disassembly.

Power Valve

1. Remove four screws (Items 27 & 34) with 3/16" hex wrench (2 on each side).
2. Remove End Caps (Items 10 & 14).
3. Push out Valve Spool (Item 13).

NOTE: Whenever flammable materials are pumped, ground Airmotor according to Local Codes.

OPERATING PRECAUTIONS

Use Lincoln replacement parts to assure compatible pressure rating.

Heed ALL warnings.

DO NOT OPERATE Airmotor in excess of recommended pressure range.

Disconnect air line and relieve (vent) pressure when Airmotor sits idle for long periods of time and before servicing.



WARNING

ALWAYS read and follow the fluid and solvent manufacturer's recommendations regarding the use of protective clothing and equipment.

4. Remove Spool Bumpers (Item 9) (One from each end).
5. Remove "O" Ring (Item 11) (One from each end of valve body).
6. Remove four Screws (Item 37) with 3/16" hex wrench and lift valve body (Item 12).
7. Remove Gasket (Item 15) to complete valve disassembly.
8. To REASSEMBLE, REVERSE procedure.

Air Brake® Subassembly

1. Remove four Screws (Item 23) (two on each end) with 3/16" hex wrench and pull out Air Brake® Subassembly.
2. Remove two Screws (Item 39), with 7/64" hex wrench and lift out Valve Body (Item 17).
3. Remove four Screws (Item 32) (two on each side of Air Brake®) with 1/8" hex wrench and remove Signal Valve Caps (Item 31) and Air Signal Valves (Item 20).
4. Remove four Screws (Item 24) with 3/16" hex wrench and lift off Upper Body (Item 50) and Upper Gasket (Item 51).
5. Remove Gasket Plate (Item 52) and Lower Gasket (Item 53).
6. Remove Air Filter (Item 40) in two locations.
7. Remove Pump Sleeve (Item 56) and Piston (Item 55).



WARNING

To reduce the risk of serious bodily injury or property damage. NEVER exceed the maximum air or fluid working pressure of the lowest rated system component.

ATTACHING AIRMOTOR TO PUMPTUBE

1. Tightly attach the tie rods (Item 41) to the Airmotor lower casting. Use short threaded end of tie rods.
2. Mount Airmotor on top of pump tube outlet and tightly connect pump tube coupling nut to Airmotor Piston Rod (Item 5).
3. Hand tighten tie rods to the pump tube with four nuts (Item 42) supplied with Airmotor.
4. Connect air supply and slowly cycle pump several times using only enough air pressure to operate pump without stalling.
5. STOP pump on "UP" stroke and tighten four nuts to securely fasten Airmotor to pump tube.

8. Remove Diaphragm Seal and Retainer, Diaphragm, Spring and Stop Valve Assy. (Items 61, 57, 58, 59 & 60).
9. Remove cover from Bleed Assembly (Item 67) and remove lock screw. Using 1/2" box end wrench, remove bleed valve bolt and remaining parts.
10. Remove Trip Indicator (Item 48).
11. To REASSEMBLE, REVERSE procedure, insuring that:
 - a. Upper and Lower Gaskets (Items 51 & 53) are well oiled with 10 wt. motor oil.
 - b. Assembly Screws (Items 23 & 24) are torqued to 65 to 70 in. lbs.

Cylinder Tube and Muffler

1. Remove Air Brakes Subassembly (See previous instructions).
2. Remove two Screws (Item 30) with 3/16" hex wrench and pull off Muffler (Item 29).
3. Remove Gasket (Items 28).
4. Remove four Nuts (Item 26) with open end wrench.
5. Lift upward and remove Upper Casting (Item 8).
6. Remove four Tie Rods (Item 25).
7. Remove Air Tube (Item 7).
8. Lift upward and remove Cylinder Tube (Item 6).
9. Remove Piston and Piston Rod (Item 5).
10. Remove four Connecting Rods (Item 41) with open end wrench.
11. To REASSEMBLE, REVERSE procedure.

NOTE: Align two holes on the the Cylinder Tube (Item 6) with two holes on the Air Brake® Subassembly before tightening Tie Rods (Item 25) so that proper seal with "O"-rings is achieved.

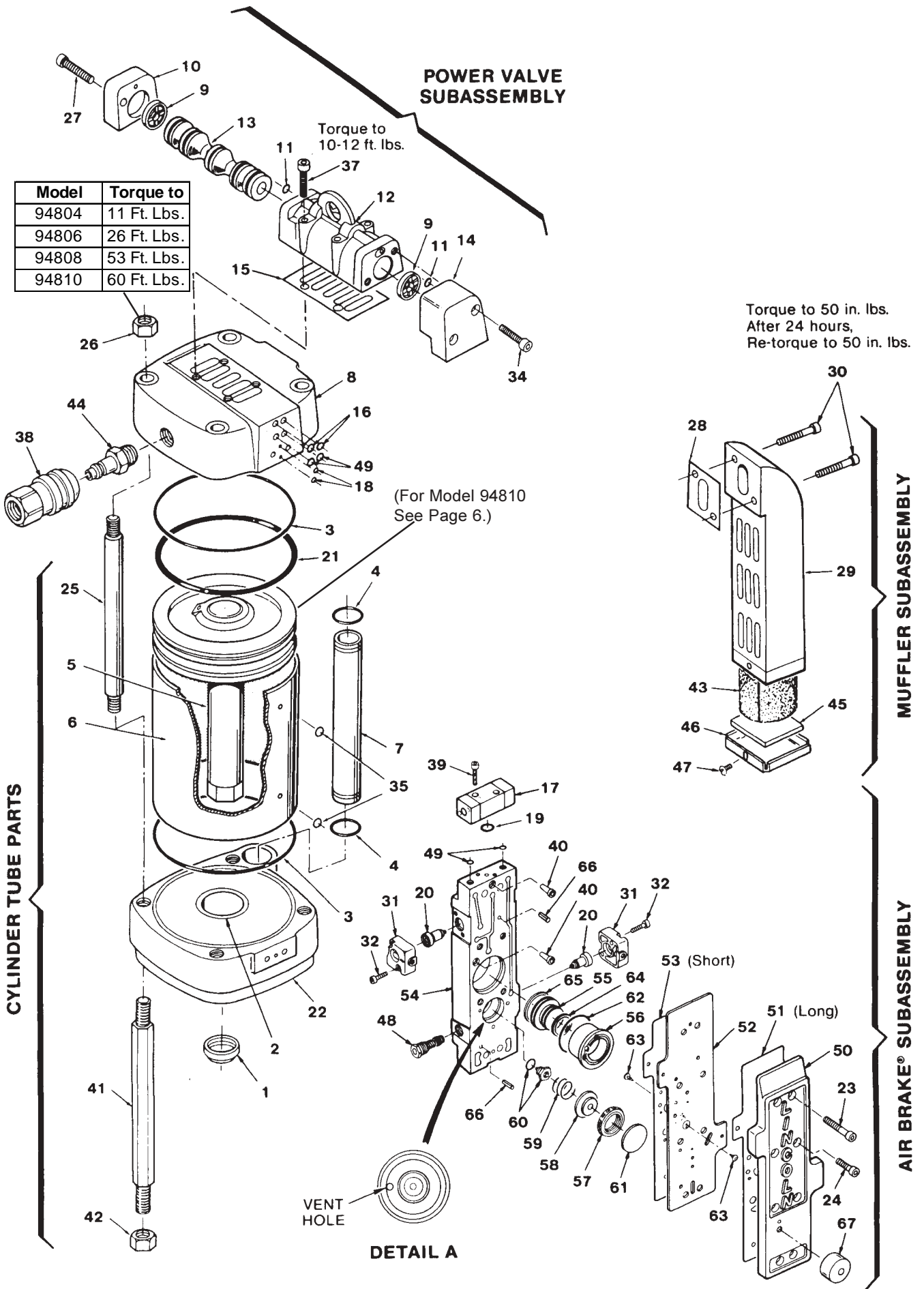

NOTE: Refer to Page 3 for Service Assemblies & Kits

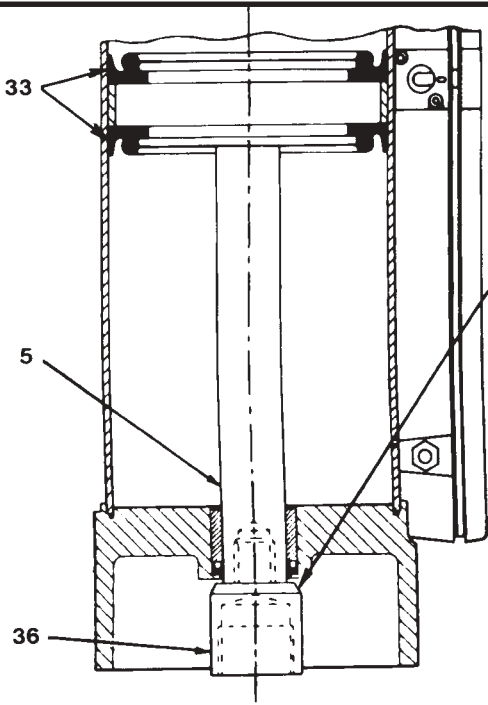

Assemble Adapter to Piston Rod
Using Loctite #242 Blue on threads.
Torque to 60-65 Ft. Lbs.

MODEL 94804

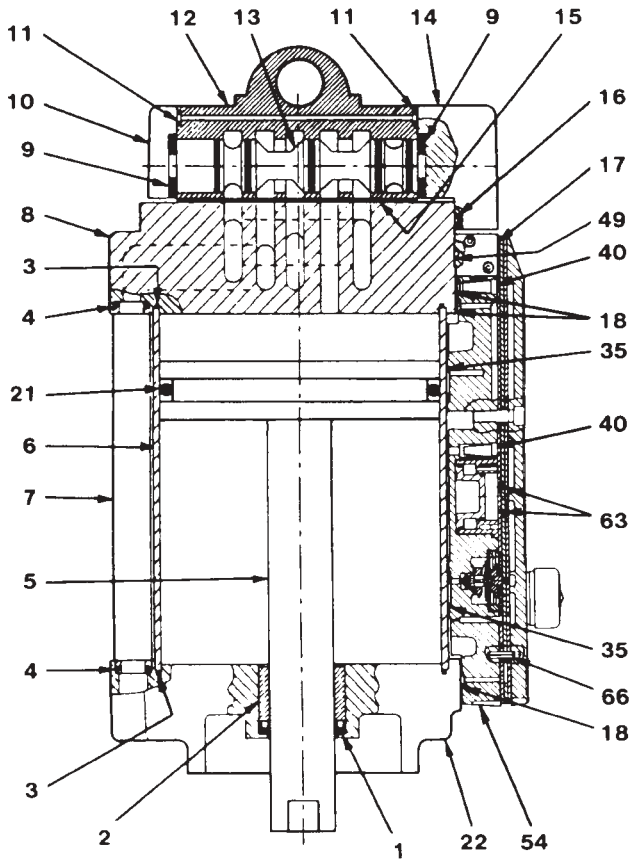

MODELS 94806, 94808, & 94810

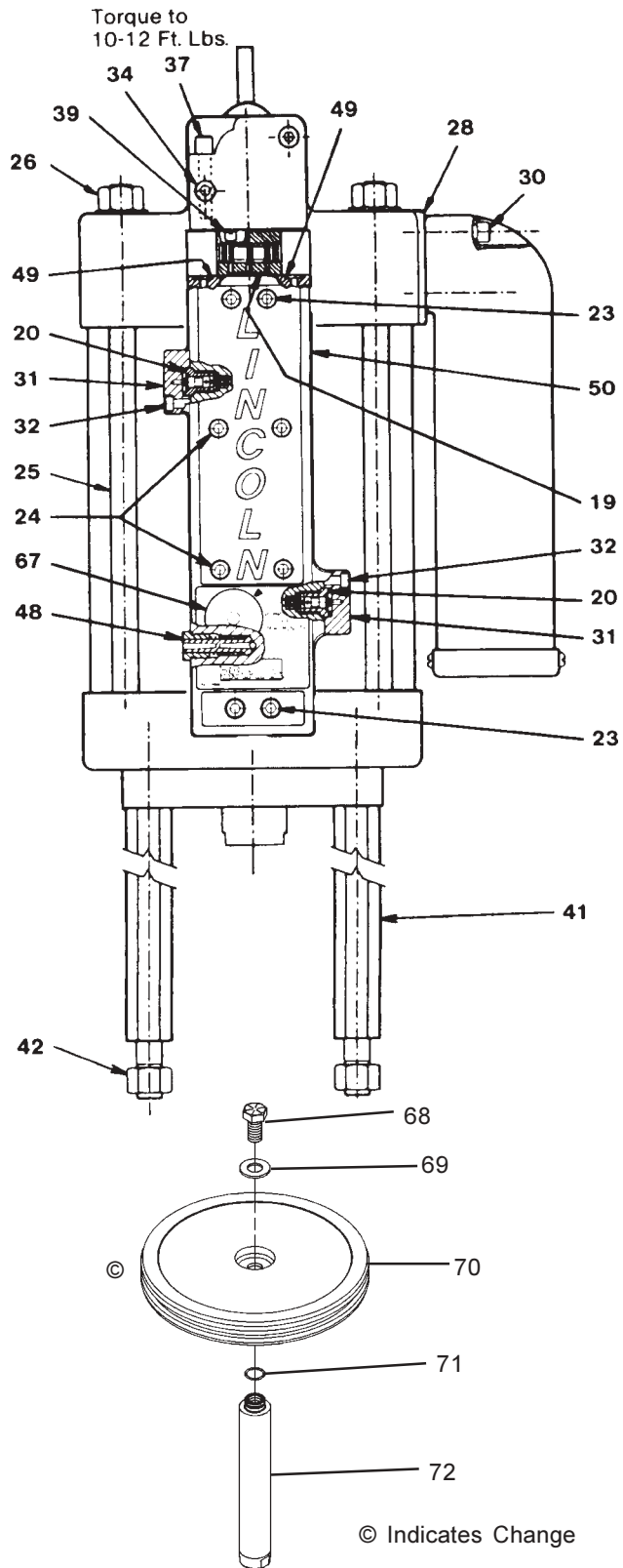

Piston Assembly
for Model 94810

© Indicates Change

PARTS LIST

Item No.	Description	Qty.	Model 94810 (10" Dia.)	Model 94808 (8" Dia.)	Model 94806 (6" Dia.)	Model 94804 (4¼" Dia)
1	"U" Cup (Buna-N)	1	(Note #12)	(Note #1)	(Note #2)	(Note #3)
2	Rod Bearing	1	247296	241732	241732	241733
3	Seal, Cylinder (Buna-N)	2	(Note #12)	(Note #1)	(Note #2)	(Note #3)
4	"O"-ring (Buna-N)	2	(Note #12)	(Note #1)	(Note #2)	(Note #3)
5	Piston Rod Assembly	1	247449*	241470	241741	241742
6	Cylinder Tube	1	247448	241744	241745	241746
7	Air Tube	1	247336	241748	241748	241749
8	Upper Casting	1	247304	241750	241751	241752
9	Bumper, Valve	2	(Note #5)	(Note #5)	(Note #5)	(Note #5)
10	Cap, Valve	1	241755	241755	241755	241755
11	"O"-ring (Buna-N)	2	(Note #5)	(Note #5)	(Note #5)	(Note #5)
12	Body, Valve	1	(Note #13)	(Note #13)	(Note #13)	(Note #13)
13	Spool, Valve	1	(Note #13)	(Note #13)	(Note #13)	(Note #13)
14	Cap, Valve	1	247302	241759	241760	241761
15	Gasket	1	(Note #5)	(Note #5)	(Note #5)	(Note #5)
16	"O"-ring (Buna-N)	2	(Note #5)	(Note #5)	(Note #5)	(Note #5)
17	Relay Valve	1	242787	242787	242787	242787
18	"O"-ring (Buna-N)	3	(Note #6)	(Note #6)	(Note #6)	(Note #6)
19	"O"-ring (Buna-N)	1	(Note #6)	(Note #6)	(Note #6)	(Note #6)
20	Air Signal Valve	2	241768	241768	241768	241768
21	"O"-ring Piston(Buna-N)	1	(Note #12)	(Note #1)	(Note #2)	-----
22	Lower Casting	1	247303	241773	241774	241775
23	Screw (¼-20 x 1½")	4	50051	50051	50051	50051
24	Screw (¼-20 x 7/8")	4	50521	50850	50850	50850
25	Tie Rod	4	247295	241766	241779	241767
26	Nut	4	247298	51018	51007	51001
27	Screw	2	244995	244995	244995	244995
28	Gasket	1	(Note #4)	(Note #4)	(Note #4)	(Note #4)
29	Muffler Body	1	241021	241021	241021	241021
30	Screw (¼-20 x 1½")	2	50051	50051	50051	50051
31	Signal Valve Cap	2	(Note #8)	(Note #8)	(Note #8)	(Note #8)
32	Screw	4	(Note #8)	(Note #8)	(Note #8)	(Note #8)
33	Seal, Piston	2	-----	-----	-----	(Note #3)
34	Screw	2	247299	244993	241783	244994
35	"O"-ring (Buna-N)	2	(Note #6)	(Note #6)	(Note #6)	(Note #6)
36	Adapter	1	-----	-----	-----	241789

Parts List continues on next page. Parts List Notes on next page.

* Also available as individual parts

PARTS LIST (CONTINUED FROM THE PREVIOUS PAGE)

Item No.	Description	Qty.	Model 94810 (10" Dia.)	Model 94808 (8" Dia.)	Model 94806 (6" Dia.)	Model 94804 (4¼" Dia)
37	Screw (¼-20 x 2¼")	4	244975	244975	244975	244975
38	Coupler	1	662012	655012	655012	655008
39	Screw	2	50816	50816	50816	50816
40	Air Filter	2	(Note #7)	(Note #7)	(Note #7)	(Note #7)
41	Tie Rod	4	241023	241023	241023	241023
42	Nut (½-20)	4	236203	236203	236203	236203
43	Muffler Element	1	(Note #4)	(Note #4)	(Note #4)	(Note #4)
44	Nipple	1	660112	653112	653112	653112
45	End Element	1	(Note #4)	(Note #4)	(Note #4)	(Note #4)
46	Muffler Plate	1	241027	241027	241027	241027
47	Screw, Self Tapping (10-32)	2	66962	66962	66962	66962
48	Trip Indicator	1	243852	243852	243852	243852
49	"O"-ring (Buna-N)	4	(Note #6)	(Note #6)	(Note #6)	(Note #6)
50	Upper Body	1	243855	243855	243855	243855
51	Upper Gasket (Nitrile)	1	(Note #7)	(Note #7)	(Note #7)	(Note #7)
52	Gasket Plate	1	(Note #9)	(Note #9)	(Note #9)	(Note #9)
53	Lower Gasket (Nitrile)	1	(Note #7)	(Note #7)	(Note #7)	(Note #7)
54	Lower Body	1	N/A	N/A	N/A	N/A
55	Piston	1	(Note #10)	(Note #10)	(Note #10)	(Note #10)
56	Pump Sleeve	1	(Note #10)	(Note #10)	(Note #10)	(Note #10)
57	Diaphragm Retainer	1	(Note #11)	(Note #11)	(Note #11)	(Note #11)
58	Diaphragm	1	(Note #11)	(Note #11)	(Note #11)	(Note #11)
59	Spring	1	(Note #11)	(Note #11)	(Note #11)	(Note #11)
60	Stop Valve Assembly	1	(Note #11)	(Note #11)	(Note #11)	(Note #11)
61	Diaphragm Seal	1	(Note #11)	(Note #11)	(Note #11)	(Note #11)
62	"O"-ring (Buna-N)	1	(Note #10)	(Note #10)	(Note #10)	(Note #10)
63	Umbrella Seal (Nitrile)	2	(Note #9 & 10)	(Note #9 & 10)	(Note #9 & 10)	(Note #9 & 10)
64	Quad Ring (Buna-N)	1	(Note #10)	(Note #10)	(Note #10)	(Note #10)
65	Quad Ring (Buna-N)	1	(Note #10)	(Note #10)	(Note #10)	(Note #10)
66	Spring Pin	2	243614	243614	243614	243614
67	Bleed Assembly	1	243854	243854	243854	243854
© 68	Screw	1	272736	-----	-----	-----
© 69	Washer	1	272737	-----	-----	-----
© 70	Piston	1	272766	-----	-----	-----
© 71	O-Ring (Buna-N)	1	(Note #12)	-----	-----	-----
© 72	Piston Rod	1	272767	-----	-----	-----

N/A - Not Available

© Indicates Change

- NOTES:**
1. Included in 84791 Cylinder Tube Soft Parts Kit for Model 94808 (8" Airmotor).
 2. Included in 84792 Cylinder Tube Soft Parts Kit for Model 94806 (6" Airmotor).
 3. Included in 84793 Cylinder Tube Soft Parts Kit for Model 94804 (4¼" Airmotor).
 4. Included in 84939 Muffler Element Kit.
 5. Included in 84968 Soft Parts Kit for Power Valve Subassembly.
 6. Included in 84967 Soft Parts Kit for Air Brake® Subassembly.

7. Included in 244089 Gasket and Air Filter Kit.
8. Included in 243853 Signal Valve Cap Kit.
9. Included in 244093 Gasket Plate with Check Valves.
10. Included in 244092 Air Pump Repair Kit.
11. Included in 244091 Stop Valve Repair Kit.
12. Included in 84789 Cylinder Tube Soft Parts Kit for Model 94810 (10" Airmotor).
13. Included in 244802 Power Valve & Spool Body.

SETTING THE AIR BRAKE® TRIP SPEED©

1. With the airmotor and pump running, determine the normal speed the pump and count the cycles per minute.
2. If the speed is below 10 cycles per minute, set the air brake to the medium setting.
3. If the speed is above 10 cycles per minute, add 15 cycles per minute to the running speed and set the air brake using the following table:

10-30 cycles/min.	Low
30-60 cycles/min.	Medium
60-90 cycles/min.	High
4. With the airmotor running, turn the adjustment knob to a lower setting at increments of 1/16 inch along the dial circumference, waiting at least 30 seconds in between each adjustment. Be sure to tighten the lock screw after each adjustment. Continue this procedure until the air brake trips.
5. After the airbrake trips, increase the setting by 3/8 inch as measured along the dial circumference. The control is now set.
6. Turn lock screw until it contacts spring washer, then tighten an additional 1/2 turn.
7. Test the pump in normal use to insure the setting is not too low. If the airbrake stops the airmotor during normal operation, increase the setting 1/8 inc along the dial circumference. Check the air brake for accuracy by increasing the cycle rate by at least 30 cycles per minute. The air brake should trip. Reset the air brake and set the air pressure to the desired level.

NOTE: Air Brake® is disabled when bleed knob is set on the run setting.

WARNING

Always shut off air supply before servicing Airmotor. An Airmotor in the tripped condition is under pressure and may restart unexpectedly for one or two cycles.

AIR BRAKE® RESETTING INSTRUCTIONS

If the Airmotor runs faster than the preset speed, the Air Brake® will stop the air motor with the pump plunger in the down position. The Trip Indicator piston extends to indicate that the Air Brake® has been triggered and is preventing Airmotor operation.

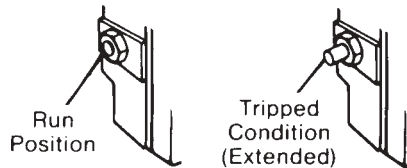

To reset the Air Brake®:

1. Shut off air supply to Airmotor.
2. Press flush reset button with a screwdriver (located on right side of Relay Valve - Item 17) until Air Brake® shifts and indicator button retracts.

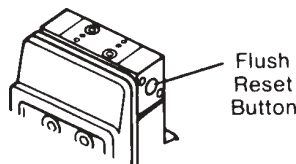

3. Wait two full minutes to insure all residual pressure vents off.
4. Turn on air supply. Airmotor will now restart.

TROUBLESHOOTING

PROBLEM	POSSIBLE CAUSE	SOLUTION
Airmotor is not working and air is coming from exhaust.	Restricted or inadequate air supply.	Check air supply and adjust to minimum recommended level. Check air supply hose diameter and change it to minimum recommended size (see specifications). Check size of FRL and Quick disconnect coupling. Replace if small size or restricted.
Erratic or accelerated operation with short stroking.	Dirty or damaged Relay Valve (Item 17) or Air Signal Valve (Item 20).	Check valves and clean if necessary. Replace any damaged seals or worn parts.
Air Brake "trips" off even though airmotor is running below set trip speed. (Runs three strokes or more before stopping.)	Bleed groove clogged in Bleed Assembly (Item 67)	Remove Bleed Assembly and check bleed groove for foreign matter. If found, disassemble entire Air Brake for cleaning and replace air line filter.
Air Brake "trips" very quickly after airmotor is started (within 3 strokes), even though airmotor is running below set trip speed.	Leaking Diaphragm (Item 58).	Replace Diaphragm.
	Leaking Upper Gasket (Item 51).	Replace Upper & Lower Gaskets (Items 51 & 53).
	Upper Piston Quad Ring (Item 64) is leaking.	Replace Quad Ring.
	Bleed Hole (A) in clear washer not aligned with Bleed Hole (B) in bleed base.	Align Tab (C) of clear washer to Slot (D) in bleed base. (See illustration 9 in Service Assemblies and Kits.)
Air Brake "trips" at at proper speed (indicated by the sound of air surging into diaphragm chamber), but airmotor does not stop.	Stop Valve vent hole in Lower Body (Item 54) is clogged. (See Detail A, page 4.)	Unclog vent hole in lower body.
	Stop valve (Item 60) is damaged.	Check stop valve and replace if worn or damaged.
Air Brake will not trip even though airmotor has been running above the trip speed for more than 1 minute.	Discharge Umbrella Seal (Item 63) is not closing properly.	Inspect and replace both umbrella seals if damaged.
	Diaphragm (Item 58) is not properly installed, or is leaking due to damage.	Reinstall diaphragm properly or rplace if damaged.
	Leaking Upper Gasket (Item 51) or Lower Gasket (Item 53).	Disassemble Air Brake and re-assemble with new gaskets.
	Stuck Metering Pump Piston (Item 55).	Increase air pressure to 100 PSI and try again. If this fails, replace piston and pump sleeve, including all rubber parts (Items 55, 56, 62, 64 & 65).
	Inlet Air Filter (Item 40) is completely or partially clogged.	Clean or replace inlet air filter.