

**Model Nos. 2376, 2377, 2378,
2379, 2380, 85400
PILE DRIVER III PUMP ASSEMBLY
Series "B"**

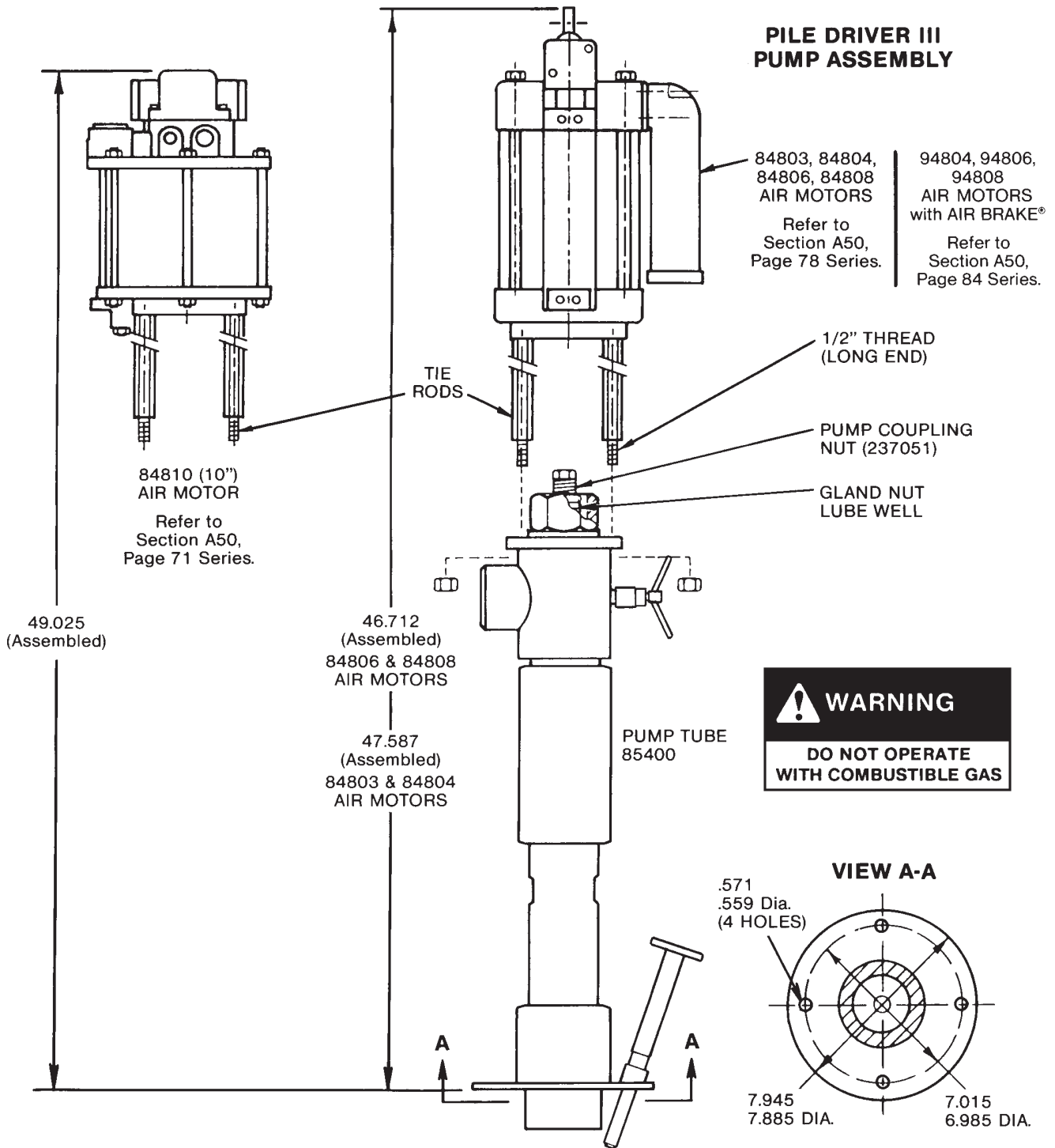

SPECIFICATIONS

Model	Ratio	Airmotor Size in. (mm)	Airmotor Model	Maximum Discharge Pressure PSIG (Bar)	Output Per Cycle cu. in. (cc)	Stroke Length in. (mm)	Minimum Air Supply Hose in. (mm)	Maximum Operating Air Pressure PSIG (Bar)	Operating Temperature F° (C°)
2376	45:1	10 (254)	84810	4,500 (311)	18 (295)	6 (152)	3/4 (20)	100 (7)	30° to 200° (-34° to +93°)
2377	30:1	8 (203)	84808	3,000 (207)					
2378	18:1	6 (152)	84806	1,800 (124)			1/2 (12)		
2379	8:1	4-1/4 (108)	84804	1,600 (110)			200 (14)		
2380	4:1	3 (76)	84803	300 (21)				3/8 (10)	

Note: Pump should be installed upright for operation. **Use Model 83727** stand pipe for bulk material dispensing. Locate pump as close to tank as possible and use a minimum 3 inch (76mm) I.D. inlet hose or pipe.

ATTACHING AIRMOTOR TO PUMPTUBE*

1. Tightly attach tie rods to the airmotor (use short threaded end of the tie rods).
2. Mount airmotor on top of the pump-tube outlet and tightly connect Coupling Nut (237051) to airmotor piston rod.
3. Hand tighten tie rods to the outlet with four nuts supplied with airmotor.
4. Slowly cycle the pump several times, using just enough air pressure to operate the pump without stalling.
5. Stop the pump on an "up" stroke and tighten the four nuts to securely fasten the airmotor to the pumptube.

OPERATING PRECAUTIONS

- Use Lincoln replacement parts to assure compatible pressure rating.
- HEED ALL WARNINGS.
- Be sure material hoses and other components are able to withstand fluid pressures developed by this pump.
- Do not operate pump continuously at speeds in excess of 75 cycles per minute.
- Disconnect air line from pump air motor when system sits idle for long periods of time.
- **SERVICING.** Before servicing or cleaning pump, or removing fluid hose or gun from a unit that has been used, be sure to disconnect air lines and carefully bleed pressure off of the system.

- Check continuity (a good static wire connection) with an ohmmeter. Place one probe on one hose fitting and the other probe on other hose fitting, continuity or proper grounding through hose is good when a reading is obtained on the ohmmeter.
- **PREVENT FIRES.** When pumping, flushing or recirculating volatile solvents, the area must be adequately ventilated.
- Keep solvents away from heat, sparks and open flames. Keep containers closed when not in use.



CAUTION

DO NOT allow pump to operate when out of material.

GLAND PACKING DESIGN*

Many industrial type materials (sealants, adhesives, inks, etc.) display a tendency to dry-out and to build-up on the pump rod (plunger). These hard dried out materials cause the gland packing to wear out rapidly, resulting in leakage and ultimate pump failure. The second problem is the gland seal exposure to high pressure and in particular, to pressure fluctuation during pump operation (stroke changeover).

The new gland packing design* of Pile Driver III pumps addresses both problems:

A special spring type Metal Wiper (237654), scrapes built up and dried out material from the pump rod (plunger). In order to help the metal wiper to work longer and more efficiently, the lube well of the pump should be filled with a fluid compatible with pumped material.

Do not fill lube well to full capacity, as the reciprocating movement of the pump may draw fluid into the airmotor.

Secondly a clearance sleeve and second metal wiper (237654) protects gland "U" cup from harsh, abrasive material.

A combination of the metal wipers prolongs gland seal life and prevents leakage.

PUMP PRIMING

To begin operating, the pump has to be primed with pumping material. The pile Driver III pump is double acting (pumps material on "up" & "down" stroke") positive displacement reciprocating pump and as such intakes material only on "up" stroke.

To prime pump - open output line (material valve) and slowly open air supply valve until pump starts. Allow pump to cycle very slowly until all air is pushed out of lines and material fills out pump and lines. Close output line (material valve) - pump should stall against pressure.

If pump fails to prime properly open Bleeder Valve (246704) slightly to expel trapped air and at the sign of material coming out of the valve closed it tightly.

Note: Pumps are factory tested with light oil and some of it is left in to protect pump parts during storage and transportation. To prevent contamination of material to be pumped, flush pump before using.



WARNING

PREVENT STATIC SPARKING. If static sparking occurs, fire or explosion could result. Pump, dispensing valve, and containers must be grounded when handling inflammable fluids such as petroleum products, paints, lacquers, etc. and wherever discharge of static electricity is hazard.

* U.S. Patent # 4,976,192

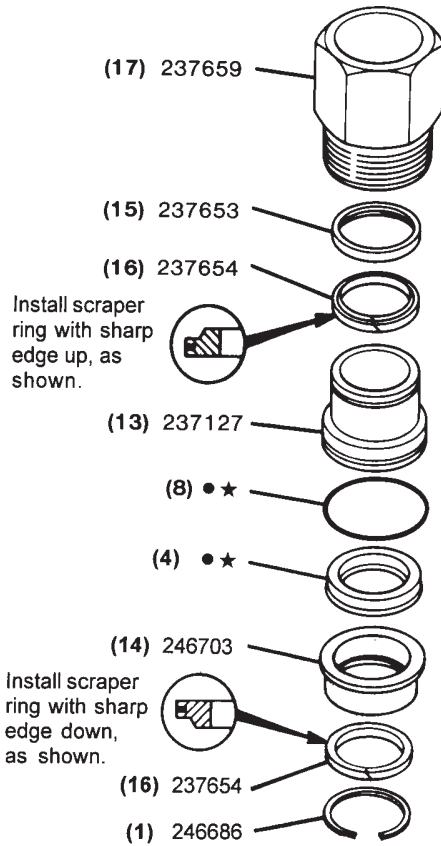

REPAIR KITS AVAILABLE

Contents of kit identified by symbols listed below.

★ 85401 Repair Kit.

©● 85314 Gland Repair Kit.

SERVICE PARTS

Item	Part	Qty.	Description
1	246686	1	Retaining Ring
2	★34377	1	O-ring (Buna-N)
3	246704	1	Bleeder Valve
4	●★	1	U-cup (polyurethane)
5	246702	1	Priming plug
6	236225	1	Bolt connector
7	★	4	O-ring (polyurethane)
8	●★	1	O-ring (polyurethane)
9	236256	1	Tube
10	246701	1	Adapter plate
11	236266	1	Outlet body
12	237051	1	Nut
13	237127	1	Bushing
14	246703	1	Sleeve
15	237653	1	Spacer
16	237654	2	Wiper
17	237659	1	Gland nut
18	★244703	1	Washer
19	★	2	U-cup (polyurethane)
20	244711	1	Upper pump tube
21	244712	1	Inlet bushing
22	244714	1	Lower pump tube
23	244715	1	Check assembly
24	244716	1	Check assembly
25	244717	1	Rod
26	237123	1	Plunger

©
©

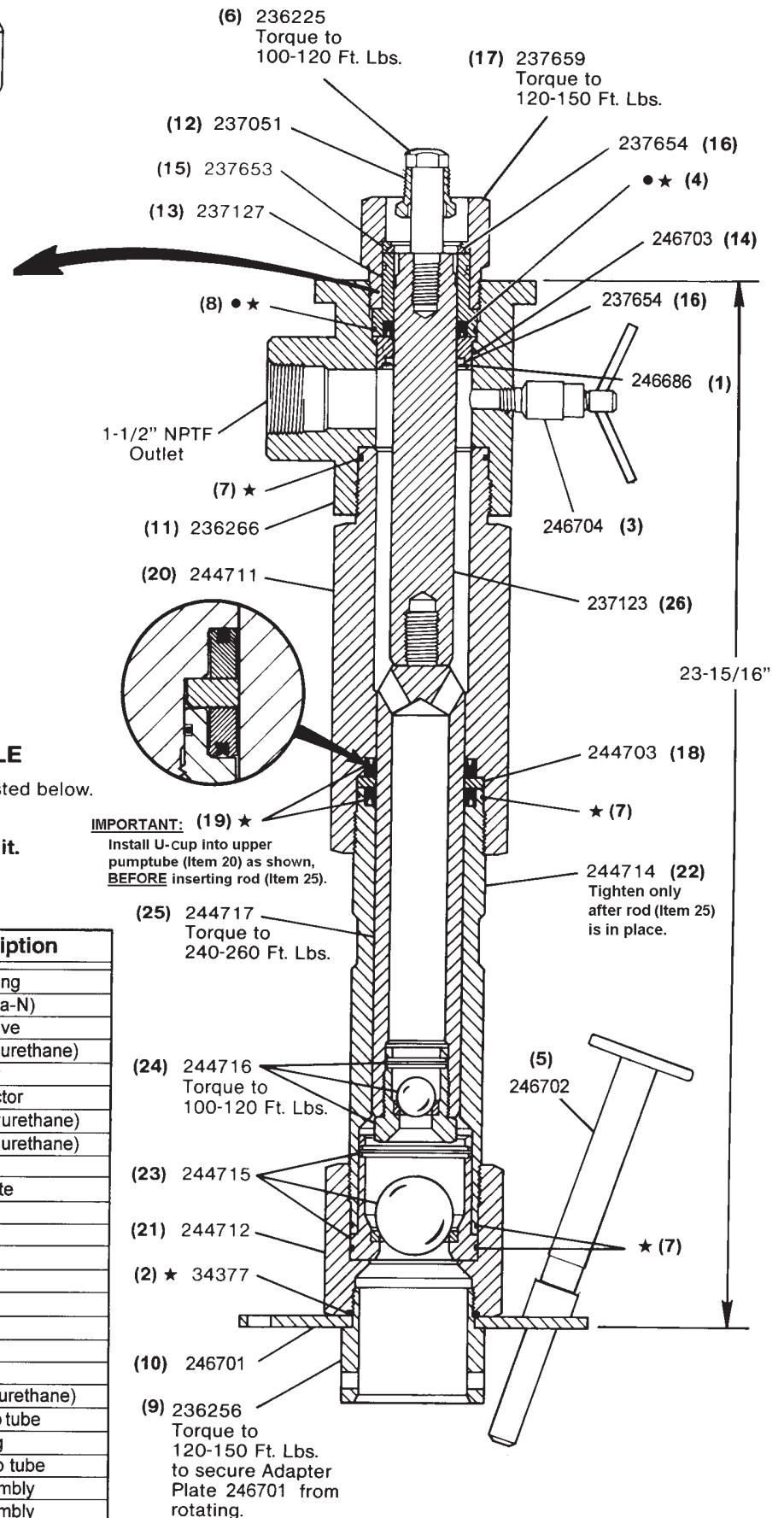

IMPORTANT: (19) ★
Install U-cup into upper
pumptube (Item 20) as shown,
BEFORE inserting rod (Item 25).

**PILE DRIVER III
PUMPTUBE ASSEMBLY
85400**

© Indicates Change

TROUBLESHOOTING

Problem	Possible Cause	Solution
Pump does not operate.	Restricted or inadequate air supply.	Check air supply pressure and air hose diameter (see specification for minimum air supply hose diameter).
	Obstructed material output.	Check output line for restrictions.
Erratic or accelerated operation.	Pump is not primed.	Prime pump (see "Pump Priming" instructions).
	Insufficient material supply.	Refill material supply.
	Material is too heavy for priming.	Lower output with material valve. Increase pressure to pressure primer (if in use). Check for inlet restrictions.
Pump operates on "down" stroke only (missing "up" stroke).	Worn or damaged Piston Packing (Item 19) or Check Assembly (244716).	Check and replace if needed.
Pump operates on "up" stroke only (missing "down" stroke).	Worn or damaged Inlet Check Assembly (244715).	Check and replace if needed.
	Insufficient material supply. Pump is not intaking enough material to dispense on both strokes.	Check inlet for restrictions. Lower output with material valve.
Pump is operating but not dispensing material.	Inlet Check Assembly (244715) is not seating or is damaged.	Check and replace if needed.
Pump fails to achieve expected output pressure.	Air leaking into inlet, due to loose mounting flange. (246701)	Tighten tube (236256) to seal mounting flange to pump.

RETAIN THIS INFORMATION FOR FUTURE REFERENCE

When ordering replacement parts, list: Part Number, Description, Model Number, and Series Letter.

LINCOLN provides a Distributor Network that stocks equipment and replacement parts.