

OWNER/OPERATOR MANUAL

It is the responsibility of the Owner/Operator to properly use and maintain this equipment.

The Instructions and Warnings contained in this manual shall be read and understood by the Owner/Operator prior to operating this equipment.

It is the responsibility of the Owner/Operator to maintain the legibility of all Warning and Instruction labels.

The Owner/Operator shall retain this manual for future reference to important Warnings, Operating and Maintenance Instructions.

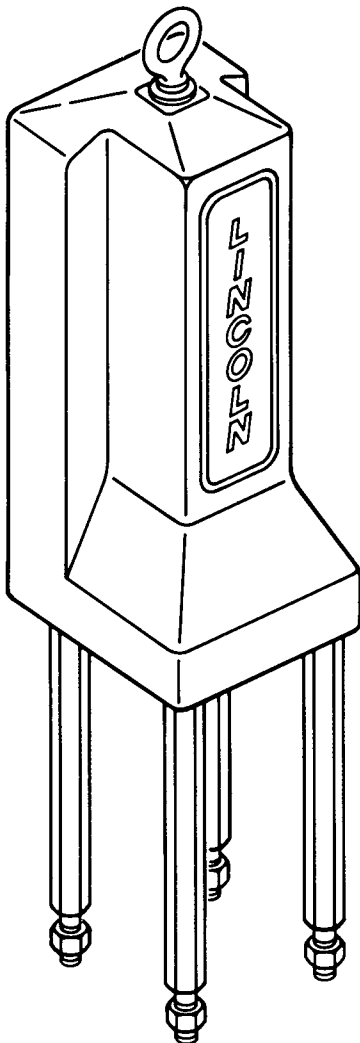

WARNING

DO NOT exceed the stated maximum working pressure of the hydraulic motor or of the lowest rated component in your system.

DO NOT alter or modify any part of this equipment.

DO NOT operate this equipment with combustible fluids.

DO NOT attempt to repair or disassemble the equipment while the system is pressurized.

TIGHTEN all fluid connections securely before using this equipment.

ALWAYS read and follow the fluid manufacturer's recommendations regarding fluid compatibility, and the use of protective clothing and equipment.

CHECK all equipment regularly and repair or replace worn or damaged parts immediately.

IMPORTANT: Failure to heed these warnings including misuse, over-pressurizing, modifying parts, using incompatible chemicals and fluids, or using worn or damaged parts, may result in equipment damage and/or serious personal injury, fire, explosion, or property damage.

PUMP CHART

PUMP TYPE	PUMP TUBE	RATIO	MAXIMUM DELIVERY PRESSURE	MAXIMUM HYDRAULIC INLET PRESSURE	
POWER-MASTER III	84981 84982 84983 84984 84985 84986 84987	1.5:1	2250 psi (155 bar)	1500 psi (103 bar)	
	84976 84977	2.5:1	3750 psi (258 bar)		
	84978 84979	4:1	6000 psi (412 bar)		
	84991 84992	3:1	4500 psi (310 bar)		
	84993 84994	5:1	7500 psi (517 bar)		
	84995 84996	6:1	7500 psi (517 bar)		1250 psi (86 bar)
	84997 84998	9:1	7650 psi (527 bar)		850 psi (58 bar)
	PILE DRIVER III	84900	0.8:1	1200 psi (83 bar)	1500 psi (103 bar)
		84901	1:1	1500 psi (103 bar)	
		84902	1.5:1	2250 psi (155 bar)	
84904		1:1	1500 psi (103 bar)		
84921 84922		0.4:1	600 psi (41 bar)		
84923		0.2:1	300 psi (21 bar)		



WARNING

Always check equipment for proper operation before each use, making sure safety devices are in place and operating properly. DO NOT alter or modify any part of the equipment as this may cause a malfunction and result in serious bodily injury.

ATTACHING HYDRAULIC MOTOR TO PUMPTUBE

1. Tightly attach Tie Rods (Item 38) to the Mounting Plate (Item 37). (Use short threaded end of tie rods).
2. Mount hydraulic motor on top of pumptube outlet body and tightly connect pumptube coupling nut to Piston Rod (Item 29).
3. Hand tighten tie rods to the pumptube with four Nuts (Item 39) supplied with hydraulic motor.
4. Connect hydraulic supply and return lines and slowly cycle pump several times, using only enough pressure to operate the pump without stalling.
NOTE: Air in the hydraulic motor may cause slow or erratic shifting during the first few cycles after connecting the hydraulic lines.
5. Stop the pump on an "up" stroke and tighten the four nuts to securely fasten the hydraulic motor to the pumptube.



WARNING

To reduce the risk of serious bodily injury or property damage, NEVER exceed the maximum fluid working pressure of the lowest rated system component.

OPERATING PRECAUTIONS

- Use Lincoln replacement parts to assure compatible pressure rating.
- HEED ALL WARNINGS.
- Be sure material hoses and other components are able to withstand hydraulic pressures.

- Do not operate hydraulic motor continuously at speeds in excess of 75 cycles per minute.
- Disconnect hydraulic line from hydraulic motor when system sits idle for long periods of time.
- **SERVICING.** Before servicing hydraulic motor be sure to carefully bleed pressure off of the system and disconnect the hydraulic supply lines.

DISASSEMBLY



WARNING

Always disconnect hydraulic supply and relieve pressure before beginning disassembly.

Tools Required

- 1/8" Hex Key
- 3/16" Hex Key
- 1/4" Hex Key
- 9/16" Open End Wrench
- 3/4" Open End Wrench
- 1-1/4" Open End Wrench
- 1" Hex Socket Wrench

Procedure

1. Remove Eyebolt (Item 1) from top of hydraulic motor.
2. Remove Washer (Item 2), Cover (Item 3) and Spacer (Item 4).
3. Remove four Tie Rods (Item 38).
4. Remove four Screws (Item 5) and remove manifold subassembly from cylinder subassembly.
5. Remove four Screws (Item 40) to separate Upper Manifold (Item 6) from Lower Manifold (Item 13).
6. Remove O-rings (Items 8, 9 & 10) from Lower Manifold (Item 13).
7. Remove Cartridge Valve (Item 12) from Lower Manifold (Item 13).
8. Remove six O-ring Plugs (Items 7 & 14) from Lower Manifold (Item 13).
9. Remove Cartridge Valve (Item 11) from Upper Manifold (Item 6).

10. Remove nine O-ring Plugs (Items 7 & 14) from Upper Manifold (Item 6).
11. Remove two O-rings (Items 19 & 20) from Cylinder Cap (Item 16) and two O-rings (Items 20 & 32) from Cylinder Head (Item 31).
12. Remove four Screws (Item 15) from Mounting Plate (Item 37).
13. Remove Mounting Plate (Item 37).
14. Remove Cylinder Cap (Item 16) from Cylinder Tube (Item 30).
15. Remove O-ring Plug (Item 14), Spring (Item 17) and Ball (Item 18) from Cylinder Cap (Item 16).
16. Remove O-ring (Item 21) from Cylinder Cap (Item 16).
17. Remove Cylinder Tube (Item 30) from Cylinder Head (Item 31).
18. Remove Piston and Rod Assembly from Cylinder Head and Bushing Assembly.
19. Remove Screw (Item 22) from Piston Rod (Item 29).
20. Remove Washers (Items 27 & 23) and Piston Cup (Item 24) from Piston (Item 26).
21. Remove Piston Assembly (Items 25, 26 & 24) from Piston Rod (Item 29).
22. Remove U-cups (Items 25 & 27) and Piston Cup (Item 24) from Piston (Item 26).
23. Remove O-ring (Item 28) and Washer (Item 23) from Piston Rod (Item 29).
24. Remove Bushing (Item 34) from Cylinder Head (Item 31).
25. Remove O-ring (Item 21) from Cylinder Head (Item 31).
26. Remove O-ring (Item 35), U-cup (Item 33) and U-cup/Wiper (Item 36) from Bushing (Item 34).
27. To re-assemble hydraulic motor reverse disassembly procedure. (Refer to illustration for torque specifications.)

IMPORTANT: When attaching manifold subassembly to cylinder subassembly the eight Screws (Items 5 and 15) should be tightened together to maintain alignment of the sealing surfaces between the manifold and cylinder.

PARTS LIST

Item No.	Description	Qty.	Part No.	Item No.	Description	Qty.	Part No.
1	Eyebolt	1	244741	21	O-ring (nitrile)	2	(Note #1)
2	Washer	1	48008	22	Screw	1	246005
3	Cover	1	244738	23	Washer	2	244770
4	Spacer	1	244742	24	Piston cup (polyurethane)	2	(Note #1)
5	Screw	4	244740	25	U-cup (polyurethane)	2	(Note #1)
6	Upper manifold	1	244774	26	Piston	1	246003
7	O-ring plug (nitrile)	9	244752	27	Washer	1	48268
8	O-ring (nitrile)	1	(Note #2)	28	O-ring (nitrile)	1	(Note #1)
9	O-ring (nitrile)	1	(Note #2)	29	Piston rod	1	244816
10	O-ring (nitrile)	1	(Note #2)	30	Cylinder tube	1	244817
11	Cartridge valve (Note #3)	1	244812	31	Cylinder head	1	244758
12	Cartridge valve (Note #4)	1	244811	32	O-ring (nitrile)	1	(Notes #1 & 2)
13	Lower manifold	1	244744	33	U-cup (polyurethane)	1	(Note #1)
14	O-ring plug (nitrile)	7	244753	34	Bushing	1	244818
15	Screw	4	244772	35	O-ring (nitrile)	1	(Note #1)
16	Cylinder cap	1	244754	36	U-cup/Wiper (polyurethane)	1	(Note #1)
17	Spring	1	(Note #1)	37	Mounting Plate	1	244767
18	Ball	1	(Note #1)	38	Tie rod	4	241023
19	O-ring (nitrile)	1	(Notes #1 & 2)	39	Nut	4	236203
20	O-ring (nitrile)	2	(Notes #1 & 2)	40	Screw	4	244751

NOTES: 1. Only available as part of 244810 Soft Parts Kit.
2. Only available as part of 244813 Soft Parts Kit.

3. For cartridge valve seals only order 244814 Seal Kit.
4. For cartridge valve seals only order 244815 Seal Kit.

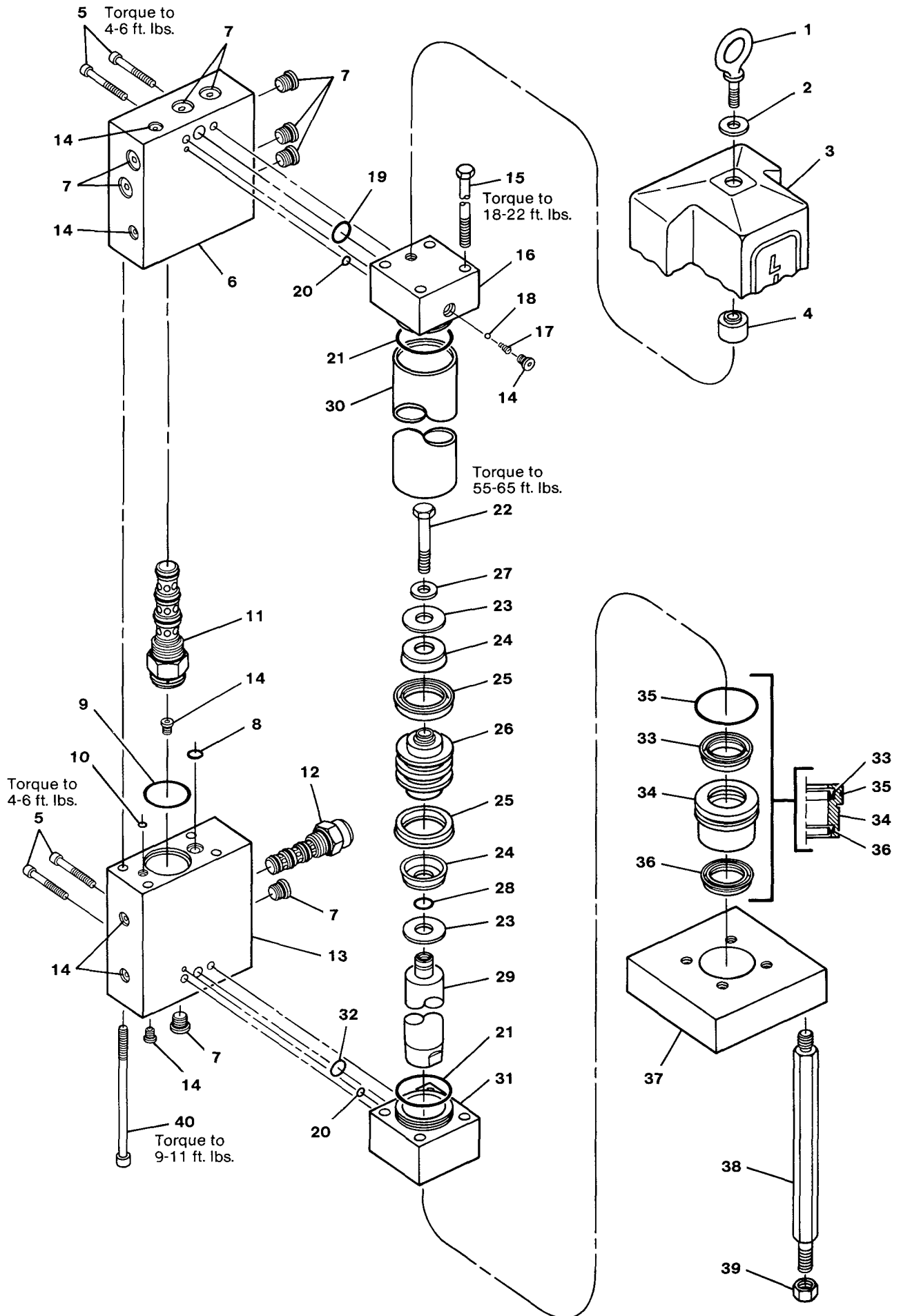

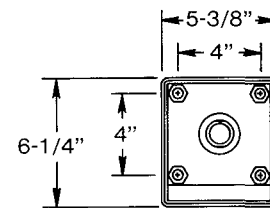
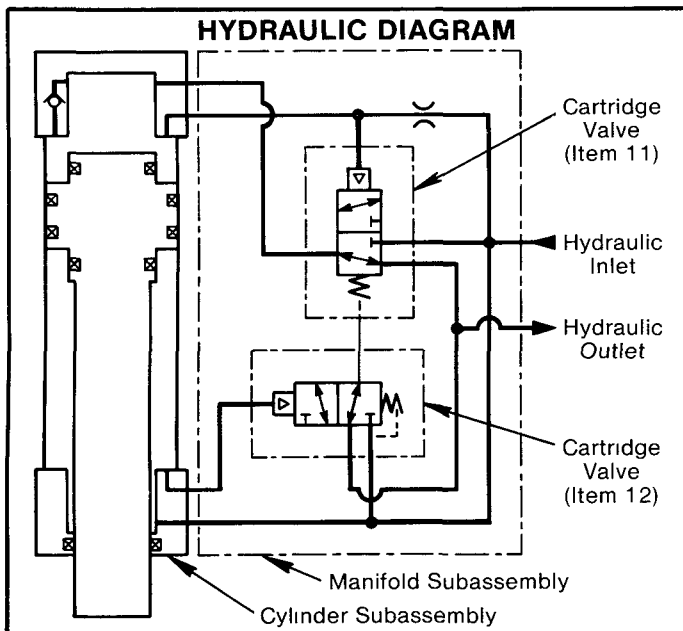
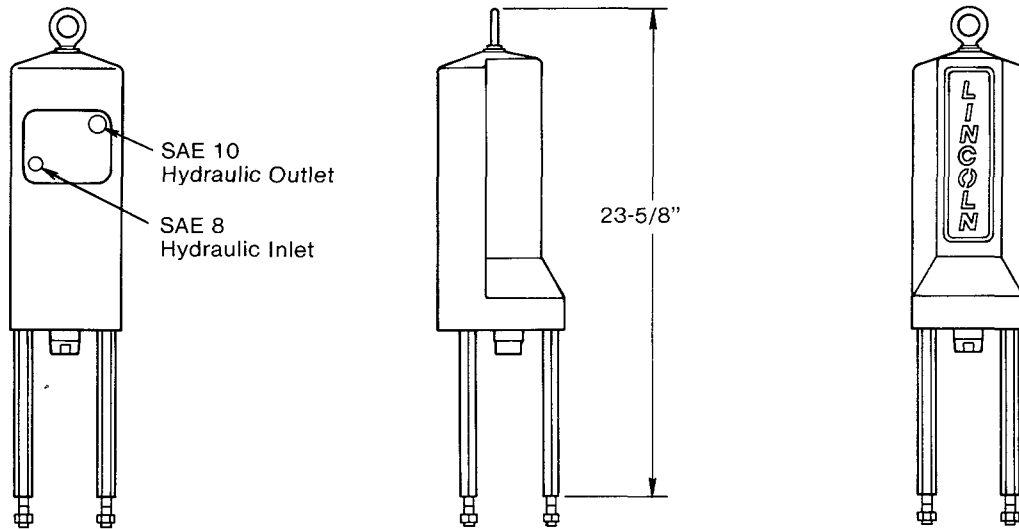

SPECIFICATIONS

- Cylinder dia. - 2 in.
- Piston rod dia. - 1-3/8 in.
- Stroke length - 6 in.
- Operating pressure range - 300 psi to 1500 psi *
- Operating temperature range - -30°F to 200°F
- Fluid consumption rate - 18.8 cu. in./cycle or 1 gal. /12 cycles
- Hydraulic fluid inlet - SAE 8 (Female)
- Hydraulic fluid outlet - SAE 10 (Female)
- Max. recommended speed (continuous) - 75 cycles/min.
- Wetted part materials - Steel, Aluminum, Bronze, Polyurethane, Nitrile, Teflon

*Refer to Pump Chart on first page for Maximum Operating Pressure when coupled to a specific pumptube.

TROUBLESHOOTING

Problem	Possible Cause	Solution
Hydraulic motor does not operate.	Restricted or inadequate hydraulic supply. Restricted hydraulic return to tank.	Check that hydraulic supply has sufficient pressure and flow to operate motor. Check return line for restrictions.
Piston moves to top of stroke and does not shift.	Damaged O-rings (Items 20 & 21). Damaged check valve components (Items 14, 17 & 18). Worn or damaged Piston Cup (Item 24). Worn or damaged Cartridge Valve (Item 11).	Check for external leakage at Cylinder Cap (Item 16) and manifold interface. Replace O-rings if leak is detected. Check for external leakage or damaged parts. Replace if needed. Check and replace if needed. Check and replace if needed.
Piston moves to bottom of stroke and does not shift.	Damaged O-rings (Items 21 & 32). Worn or damaged Piston Cup (Item 24). Worn or damaged Cartridge Valve (Item 12).	Check for external leakage at Cylinder Head (Item 31) and manifold interface. Replace O-rings if leak is detected. Check and replace if needed. Check and replace if needed.

RETAIN THIS INFORMATION FOR FUTURE REFERENCE

When ordering replacement parts, list: Part Number, Description, Model Number and Series Letter.
LINCOLN provides a Distributor Network that stocks equipment and replacement parts.