

---

**Ultra High Pressure Power-Master III Pump Tube  
Models 85304 and 85305  
Series "A"**

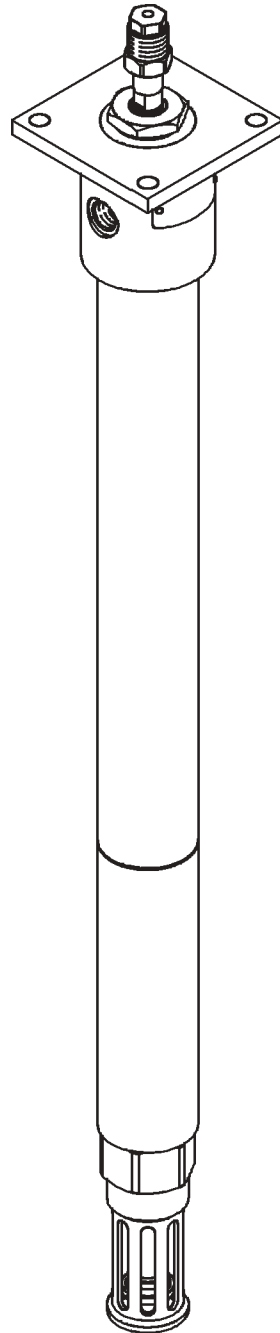

# Ultra High Pressure Power-Master III Pump Tube

## Model 85304 and 85305



### Table of Contents

	Page
General Description.....	2
Appropriate Use.....	2
Pump Specifications.....	2
Pump Dimension.....	3
Performance Charts.....	4
Pump Operation.....	5
Maintenance and Repair.....	5
Trouble Shooting.....	6
Repair Parts List.....	8

### Appropriate Use

- These pumps are exclusively designed to dispense grease under high pressure in wireline and plug valve applications.
- Use only with *Power-Master® III* airmotors (except 10" size).
- The maximum ratings given should not be exceeded.
- Any other use not in accordance with the instructions will result in loss of claims for warranty and liability.

### Product Specification

Pump stroke	6 in. (152 mm)
Output per cycle	2.0 cu. in. (33 cc)
Max. Delivery Pressure	20,000 psig (1380 bar)
Operating Temperature	-40° F to +180° F (-40° C to +82° C)
Output at 75 cpm	0.67 gpm (2.5 liter/min.)
Wetted part materials	Carbon steel, Brass, Polyurethane
Weight	57 lbs. (26 kg.)

### General Description

These pump tubes are designed specifically for oil well services such as wireline and plug valve applications. In wireline applications these pumps are used to seal against the well head pressure as the well is being logged or perforated. In plug valve applications they are used to pump heavy grease into the valve or "Christmas tree valves" to seal any gas leaks.

These pump tubes are designed to be used with *Power-Master® III* airmotors (except 10" size). They are bushing and plunger style pump tubes with shovel type foot valves. They are designed to pump grease from a drum or bulk tank.

### MODEL CHART

Pumptube	Pump Model	Airmotor*	Ratio	Maximum Delivery Pressure	Maximum Air Pressure
85304	2390	84808	250:1	20,000 psi (1380 bar)	80 psi (5.5 bar)
	2392	84806	140:1	14,000 psi (965 bar)	100 psi (6.9 bar)
	2394	84804	70:1	14,000 psi (965 bar)	200 psi (13.8 bar)
85305	2391	84808	250:1	20,000 psi (1380 bar)	80 psi (5.5 bar)
	2393	84806	140:1	14,000 psi (965 bar)	100 psi (6.9 bar)
	2395	84804	70:1	14,000 psi (965 bar)	200 psi (13.8 bar)

\*Refer to Airmotor Owner/Operator Manual, Section A50 Page 78.

# Ultra High Pressure Power-Master III Pump Tube

## Model 85304 and 85305

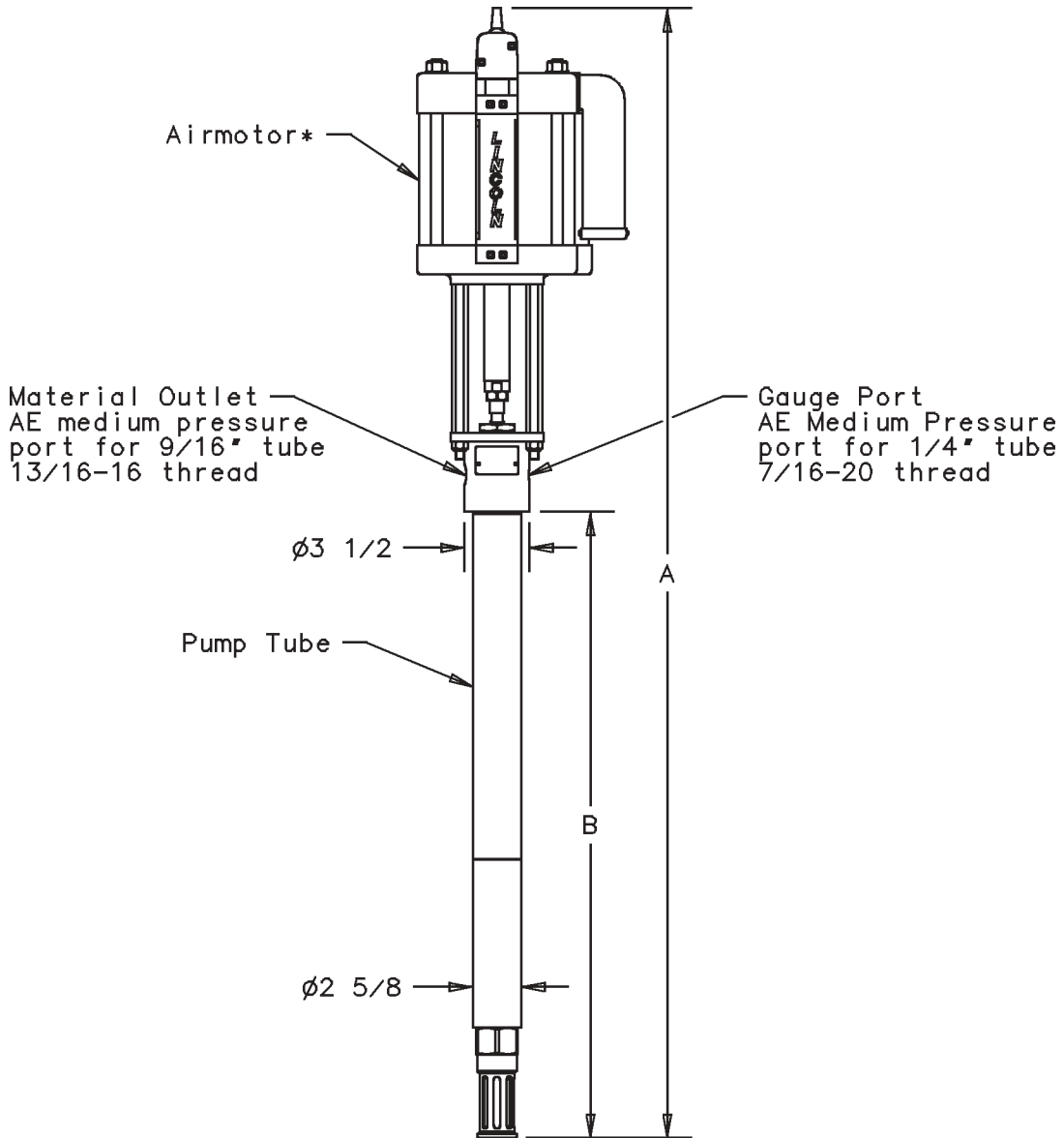

Pump Tube	Airmotor*	Dimension "A"		Dimension "B"	
		in.	(cm.)	in.	(cm.)
85304	84808	61	(154.90)	33-3/4	(85.70)
	84806				
	84804	60-1/8	(152.70)		
85305	84808	54-3/8	(138.10)	27-1/8	(68.90)
	84806				
	84804	53-1/2	(135.90)		

\*Refer to Airmotor Owner/Operator Manual, Section A50 Page 78.



Performance Charts

Models 2390 & 2391  
 250:1 Ratio

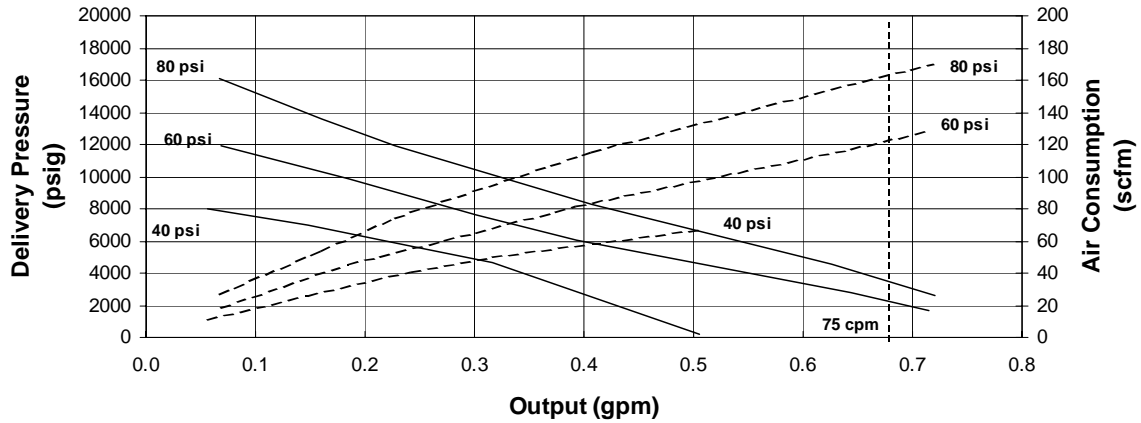

Models 2392 & 2393  
 140:1 Ratio

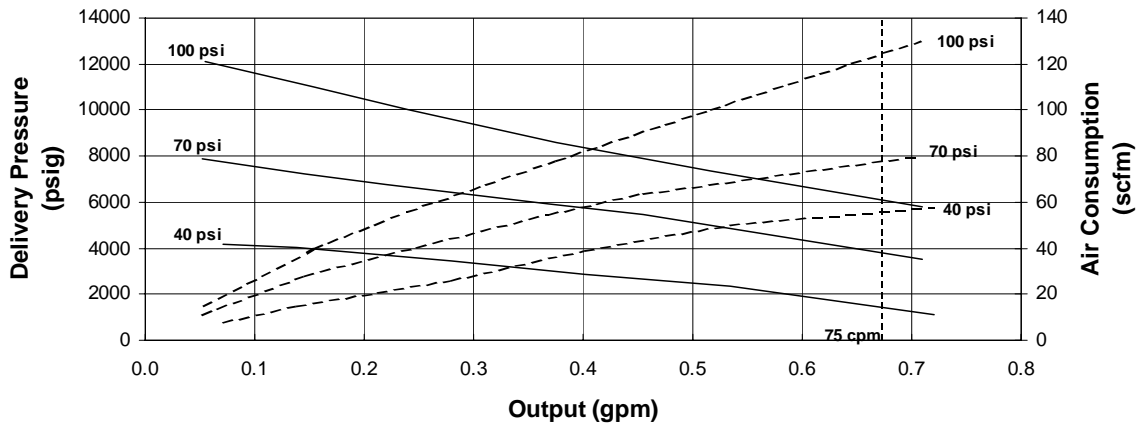

Models 2394 & 2395  
 70:1 Ratio

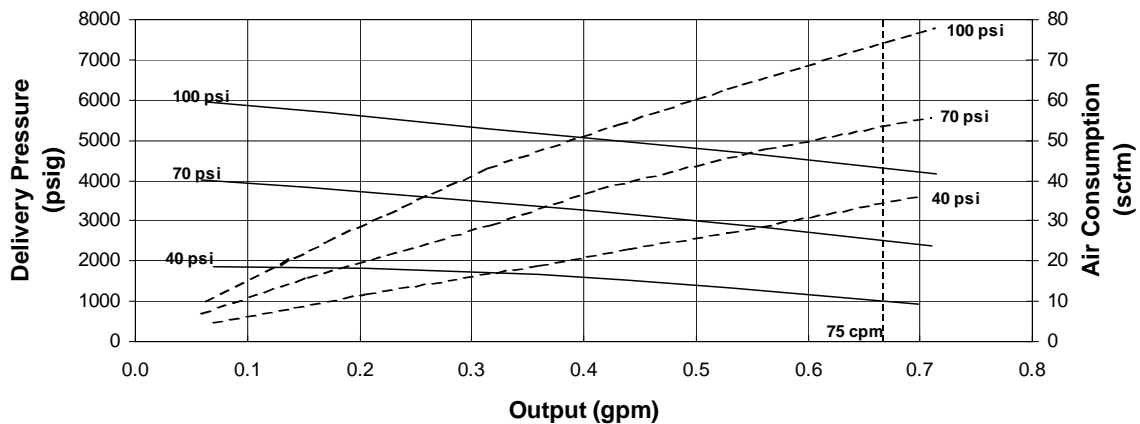

# Ultra High Pressure Power-Master III Pump Tube

## Model 85304 and 85305



### Attaching Airmotor to Pump Tube

1. Tightly attach tie rods to the airmotor (use short threaded end of the tie rods).
2. Mount airmotor on top of the pump tube outlet body and tightly connect Coupling Nut (Item 2) to airmotor piston rod.
3. Hand tighten tie rods to the pump tube with four nuts supplied with airmotor.
4. Slowly cycle the pump several times, using just enough air pressure to operate the pump without stalling.
5. Stop the pump on an "up" stroke and tighten the four nuts to securely fasten the airmotor to the pump tube.

### Operating Precautions

- Use Lincoln replacement parts to assure compatible pressure rating.
- HEED ALL WARNINGS
- Be sure material hoses and other components are able to withstand fluid pressures developed by this pump.
- Do not operate pump continuously at speeds in excess of 75 cycles per minute.
- Disconnect air line from pump airmotor when system sits idle for long periods of time.
- SERVICING. Before servicing or cleaning pump, or removing fluid hose or gun from a unit that has been used, be sure to disconnect air lines and carefully bleed pressure off of the system.

### WARNING

#### PREVENT STATIC SPARKING.

If static sparking occurs, fire or explosion could result. Pump, dispensing valve and containers must be grounded when handling flammable fluids such as petroleum products and wherever discharge of static electricity is a hazard.

- Check continuity of all grounding connections with an ohmmeter.
- PREVENT FIRES. When pumping, flushing or recirculating volatile solvents, the area must be adequately ventilated.
- Keep solvents away from heat, sparks and open flames. Keep containers closed when not in use.

### Pump Priming

To begin operation, the pump must be primed with the pumped material. The Power-Master III pump is a double acting (pumps material on "up" & "down" stroke) positive displacement reciprocating pump and as such intakes material only on the "up" stroke.

To prime pump, open output line (material valve) and slowly open air supply valve until pump starts. Allow pump to cycle very slowly until all air is pushed out of lines and material fills

up pump and lines. Close output line (material shut-off valve), pump should stall against pressure.

**Note:** Pumps are factory tested with oil and some of it is left in to protect pump parts during storage and transportation. To prevent contamination of material to be pumped, flush pump before using.

### Maintenance and Repair

Relieve pressure from the pump and supply lines and remove or lockout air line to the airmotor before servicing or repairing the pump to reduce the risk of an injury from injection, spraying fluid or moving parts.

### CAUTION

Always use Lincoln parts for service and repair.

### Disassembly Procedure

#### Tools Required

Bench Vise  
2-5/8" Dia. Strap Wrench  
5/8" Hex Wrench  
13/16" Hex Wrench  
7/8" Hex Wrench  
15/16" Hex Wrench  
1-1/8" Hex Wrench  
1-7/8" Hex Wrench  
2-1/4" Hex Wrench  
Pliers

#### Procedure

1. Unscrew Bolt Connector (Item 1) from Plunger Rod (Item 3).
2. Unscrew Gland Nut (Item 4) from Outlet Body (Item 10).
3. Remove V-packing set (Item 5) from Gland Nut (Item 4).
4. Remove six Wave Washers (Item 6), two Flat Washers (Item 7) and O-ring (Item 8) from Outlet Body (Item 10).
5. Unscrew Priming Tube (Item 28) from Priming Tube Adapter (Item 26).
6. Remove Cotter Pin (Item 23) from Priming Check and Plunger (Item 22).
7. Unscrew Priming Plunger Nut (Item 27) from Priming Check and Plunger (Item 22).
8. Unscrew Priming Tube Adapter (Item 26) from Adapter Tube (Item 19).
9. Remove Check Seat (Item 25) and O-ring (Item 24) from Adapter Tube (Item 19).
10. Unscrew Adapter Tube (Item 19) from Pump Tube (Item 12) and remove Adapter Tube (Item 19) and entire assembly consisting of Priming Check and Plunger (Item 22), Bushing and Plunger (Item 18), Connecting Rod (Item 13) and Plunger Rod (Item 3).
11. Unscrew Pump Tube (Item 12) from Outlet Body (Item

# Ultra High Pressure Power-Master III Pump Tube

## Model 85304 and 85305



(Item 10).

12. Remove O-ring (Item 11) from Outlet Body (Item 10).
13. Remove Adapter (Item 9) from Outlet Body (Item 10).
14. Unscrew Plunger Rod (Item 3) from Connecting Rod (Item 13).
15. Unscrew Connecting Rod (Item 13) from Bushing and Plunger (Item 18).
16. Remove Check Ball (Item 14), Pin (Item 17) and Check Ball (Item 15) from Bushing and Plunger (Item 18).
17. Pull Priming Check and Plunger (Item 22) and Plunger (Item 18) from Adapter Tube (Item 19).
18. Unscrew Coupler (Item 20) from Bushing and Plunger (Item 18).
19. Remove Priming Check and Plunger (Item 22) and two Keepers (Item 21) from Coupler (Item 20).
20. Remove two O-rings (Item 16) from Bushing and Plunger (Item 18).
21. To re-assemble pump tube, reverse disassembly procedure. (Refer to exploded view for torque specifications.)

### TROUBLESHOOTING

Problem	Possible Cause	Solution
Pump does not operate.	Restricted or inadequate air supply.	Check air supply pressure and air hose diameter (see Airmotor manual for minimum air supply hose diameter).
	Obstructed material output.	Check output line for restrictions.
Erratic or accelerated operation.	Pump is not primed.	Prime pump (see "Pump Priming" instructions).
	Insufficient material supply.	Refill material supply.
Pump operates on "down" stroke only (missing "up" stroke).	Worn or damaged Bushing & Plunger (Item 18) or Piston Check (Items 14, 15 and 18).	Check and replace if needed.
Pump operates on "up" stroke only (missing "down" stroke).	Worn or damaged Priming Check and Plunger (Item 22) or Check Seat (Item 25).	Check and replace if needed.
	Insufficient material supply. Pump is not intaking enough material to dispense on both strokes.	Check inlet for restrictions. Lower output with material valve.
Pump is operating but not dispensing material.	Inlet Check (Items 22 and 25) is not seating or is damaged.	Check and replace if needed.

# Ultra High Pressure Power-Master III Pump Tube Model 85304 and 85305

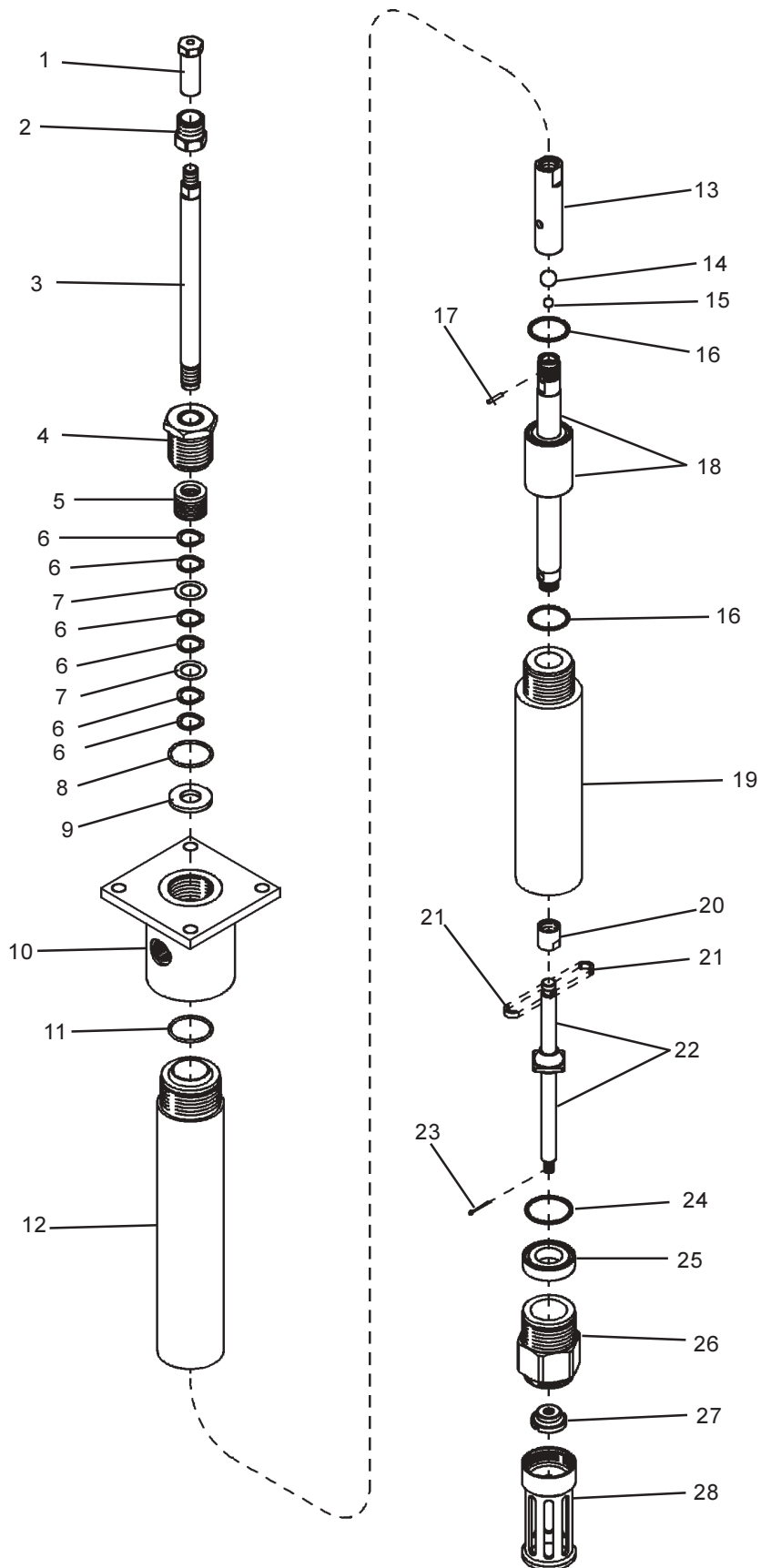

**Ultra High Pressure Power-Master III Pump Tube**  
**Model 85304 and 85305**



**PARTS LIST**

Item No.	Description	Qty.	Part Number	
			Model 85304	Model 85305
1	Bolt Connector	1	242363	242363
2	Coupling Nut	1	237051	237051
3	Plunger Rod	1	272142	272142
4	Gland Nut	1	93435	93435
5	V-packing set w/ adapters	1	34781 *	34781 *
6	Wave Washer	6	66893	66893
7	Flat Washer	2	48638	48638
8	O-ring (polyurethane)	1	*	*
9	Adapter	1	272124	272124
10	Outlet Body	1	272116	272116
11	O-ring (polyurethane)	1	*	*
12	Pump Tube	1	272119	272120
13	Connecting Rod	1	272121	272122
14	Check Ball (0.625 dia.)	1	272135	272135
15	Check Ball (0.375 dia.)	1	272134	272134
16	O-ring (polyurethane)	2	*	*
17	Pin	1	13237	13237
18	Bushing and Plunger	1	272143	272143
19	Adapter Tube	1	272127	272127
20	Coupler	1	16373	16373
21	Keeper	2	272118	272118
22	Priming Check and Plunger	1	272144	272144
23	Cotter Pin	1	*	*
24	O-ring (polyurethane)	1	*	*
25	Check Seat	1	272131	272131
26	Priming Tube Adapter	1	272125	272125
27	Priming Plunger Nut	1	16426	16426
28	Priming Tube	1	272126	272126

\*Included in Repair Parts Kit No. 272145

Americas:  
 One Lincoln Way  
 St. Louis, MO 63120-1578  
 USA  
 Phone +1.314.679.4200  
 Fax +1.800.424.5359

Europe/Africa:  
 Heinrich-Hertz-Str 2-8  
 D-69183 Walldorf  
 Germany  
 Phone +49.6227.33.0  
 Fax +49.6227.33.259

Asia/Pacific:  
 25 Int'l Business Park  
 #01-65 German Centre  
 Singapore 609916  
 Phone +65.562.7960  
 Fax +65.562.9967

© Copyright 2002  
 Printed in USA

Web site:  
[www.lincolnindustrial.com](http://www.lincolnindustrial.com)