

5 GAL. CONTAINER SIZE

SPECIFICATIONS

DIMENSIONS — 12½" DIAMETER x 25" HEIGHT
PUMP RATIO — 25:1
RECOMMENDED OPERATING AIR PRESSURES
80 P.S.I.G. MINIMUM — 100 P.S.I.G. MAXIMUM
OUTPUT 0.37 FLUID OZ. PER CYCLE

WARNING
DO NOT OPERATE
THIS UNIT WITH
COMBUSTIBLE GAS

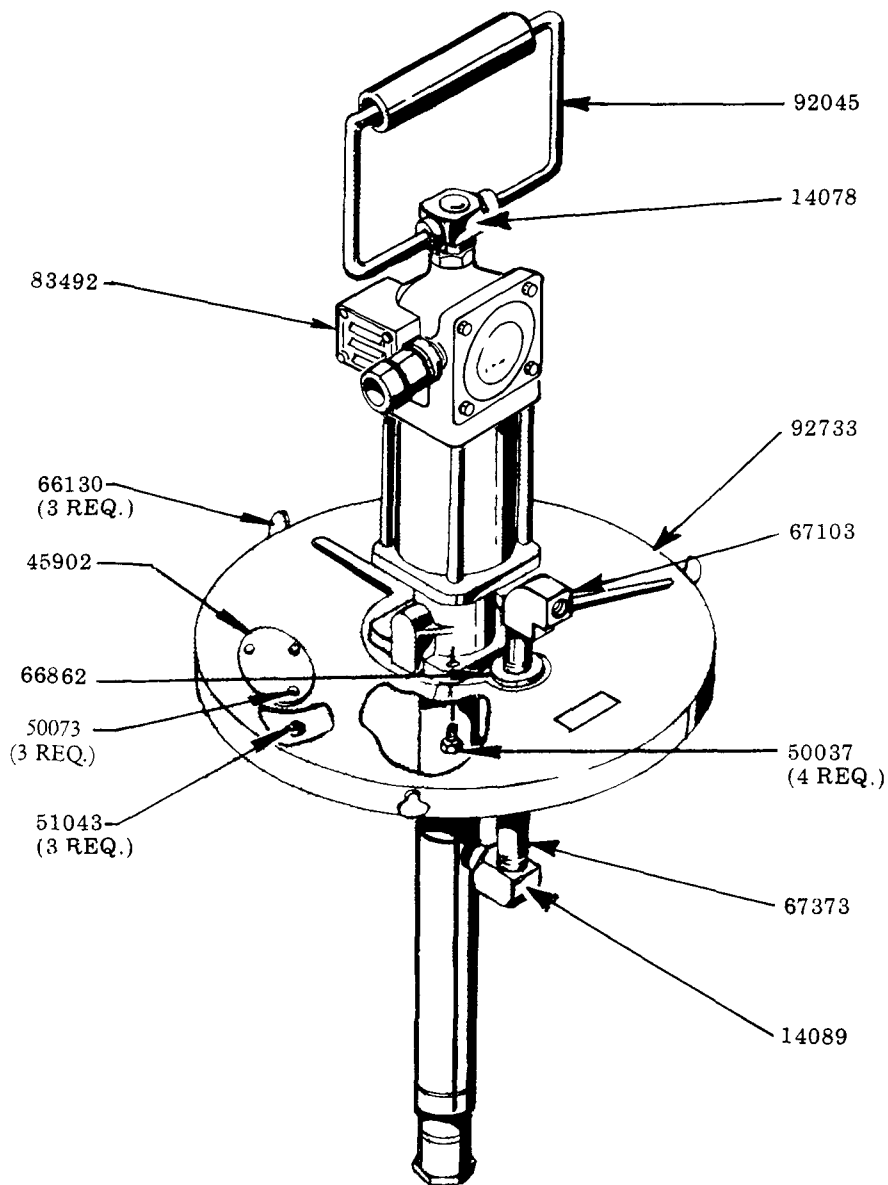

MODEL 83493

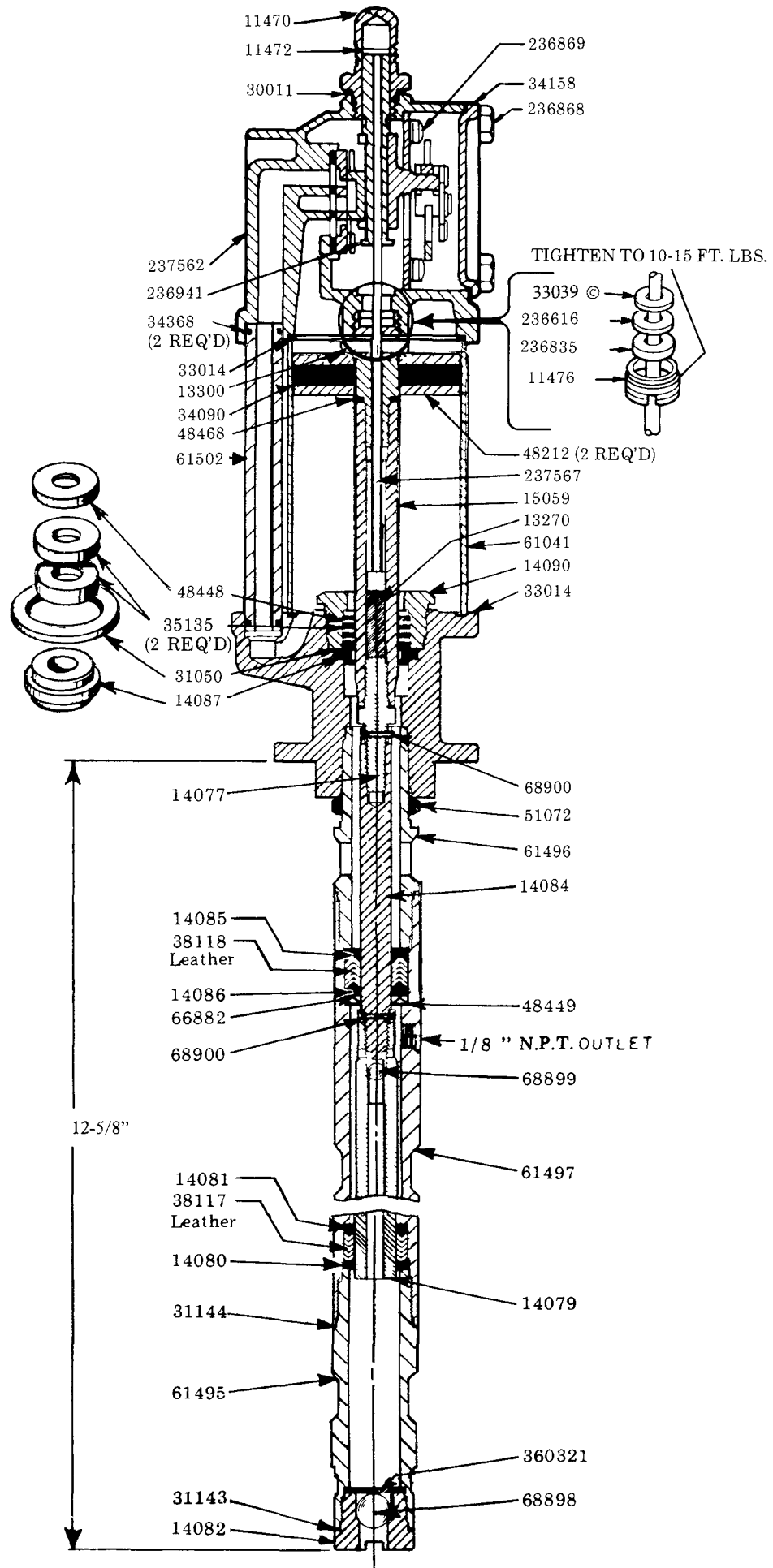

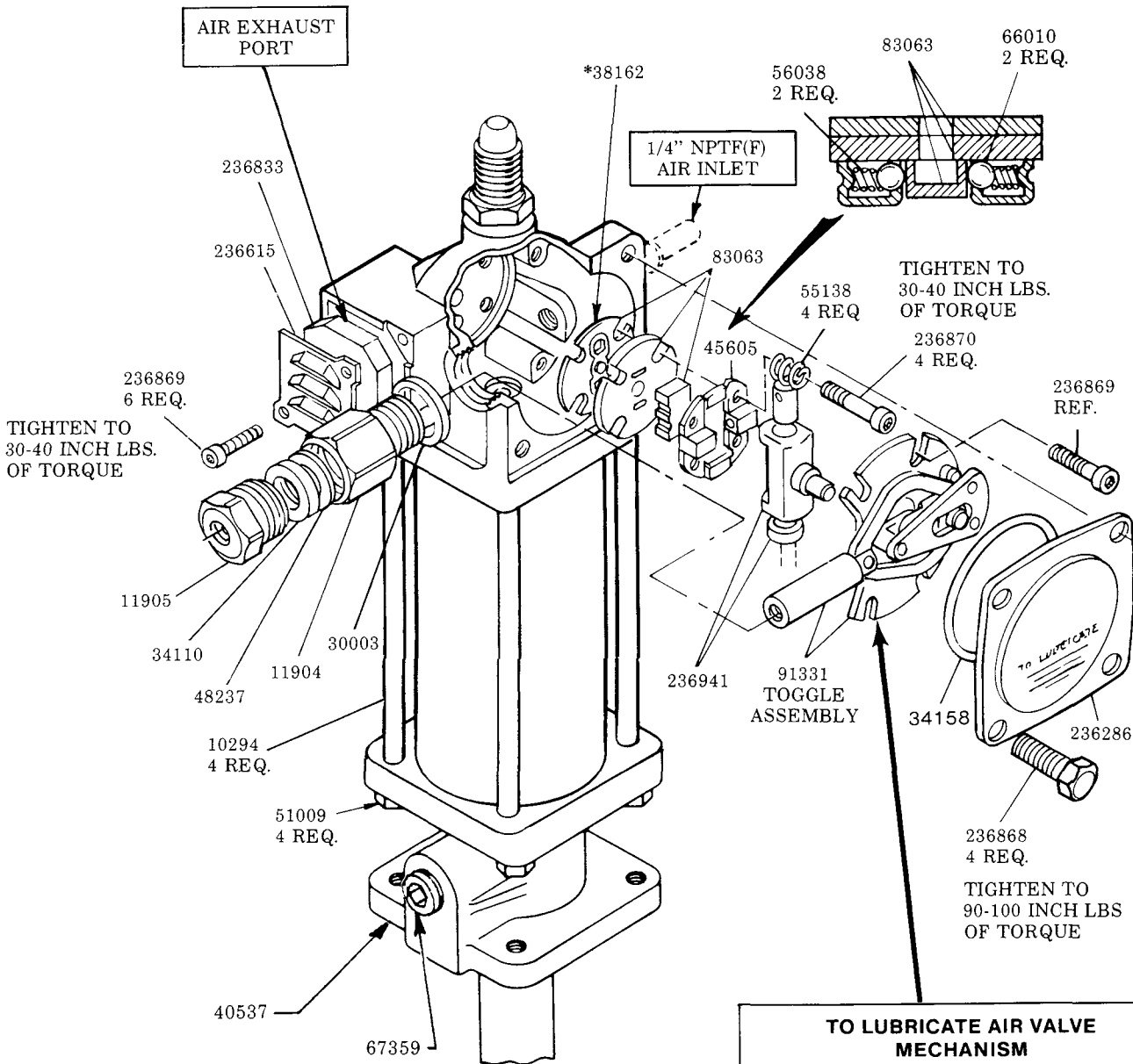

© Indicates Change

IMPORTANT: Start fasteners by hand to avoid stripping threads when reassembling.

*When replacing gasket be sure to use one of the same thickness as that being replaced.

83492 BARE PUMP ASSEMBLY 25:1 RATIO

TO LUBRICATE AIR VALVE MECHANISM

DISCONNECT AIR TO PUMP. REMOVE THE FOUR COVER SCREWS, COVER PLATE AND COVER PLATE GASKET.

REMOVE AND DISASSEMBLE THE AIR VALVE CASTING FROM THE PUMP.

THE AIR VALVE CASTING SHOULD BE CLEANED OR FLUSHED TO REMOVE ANY CHIPS, OR OTHER FOREIGN PARTICLES PRIOR TO RE-ASSEMBLY.

BEFORE REPLACING THE TOGGLE ASSEMBLY, PACK CAVITY WITH GREASE.

USE N.L.G.I. No. 1 (LIGHT GRADE) WATER REPELLENT GREASE. APPROX. 1½ OUNCES.

REPLACE COVER GASKET, COVER, AND SCREWS. TIGHTEN TO AVOID AIR LEAKS.

PERIODIC INSPECTION OF PARTS AT LEAST ONCE EACH YEAR IS ADVISABLE.

TROUBLESHOOTING

PROBLEM: Pump will not stall against fluid pressure on "UP" stroke.

CAUSE: 38117 Vee Packings are worn. Inspect 14079 Pump Rod for damage.

PROBLEM: Pump will not stall against fluid pressure on "DOWN" stroke.

CAUSE: Foot Valve Ball is not sealing against seat.

PROBLEM: Leakage from holes in 61496 Upper Pump Tube.

CAUSE: 38118 Vee Packings are worn. Inspect 14084 Gland Rod for damage.

SERVICE PARTS

Part	Description	Part	Description	Part	Description
10294	Tie rod	34090	Piston packing	66010	Ball
11470	Valve cap	34110	Plunger packing	66130	Thumb screw
11472	Trip pin	34158	Cover gasket	66862	Rubber grommet
11476	Trip rod packing nut	34368	O-ring (BUNA-N)	66882	Spring washer
11904	Packing nut	35135	Gland packing	67103	1/4" NPT pipe elbow
11905	Packing cap	38117	Leather vee packing kit	67373	1/4" NPT pipe nipple
13300	Piston bolt	38118	Leather vee packing kit	68898	1/2" dia. stainless steel ball
14077	Adapter nipple	38162	Valve seat gasket	68899	1/4" dia. stainless steel ball
14078	Handle adapter	45605	Valve guide plate	68900	Cotter pin
14079	Pump rod	45902	Cover	83063	Valve slide, seat & gasket assy.
14080	Female adapter	48212	Air piston washer	83492	Bare pump
14081	Male adapter	48237	Plunger packing washer	83543	Outlet body
14082	Foot valve body	48448	Gland packing washer	91331	Toggle assembly
14084	Gland rod	48449	Washer	92045	Handle
14085	Female adapter	48468	Washer	92733	Drum cover assembly
14086	Male adapter	50037	Screw	236286	Cover
14087	Gland packing spacer	50073	Screw	236615	Muffler cover
14089	Outlet adapter	51009	Nut	236616	Gasket
14090	Gland packing nut	51043	Nut	236833	Muffler
15059	Piston rod	51072	Nut	236835	Trip rod packing
30003	Gasket	55138	Spring	236868	Valve cover screw
30011	Gasket	56038	Spring	236869	Toggle plate screw
31050	Gland gasket	61041	Air cylinder	236870	Valve seat bolt
31143	Gasket	61495	Lower pump tube	237562	Air valve casting
31144	Gasket	61496	Upper pump tube	237567	Trip rod
33014	Gasket	61497	Pump tube outlet body	236941	Trip shoe assembly
33039	Gasket	61502	Air passage tube	360321	Ball stop

RETAIN THIS INFORMATION FOR FUTURE REFERENCE

When ordering replacement parts, list: Part Number, Description, Model Number, and Series Letter.

LINCOLN provides a Distributor Network that stocks equipment and replacement parts.