



**69008
FLUID PRESSURE
REGULATOR**

Operating Pressure

Primary - 300 psi maximum

Secondary - Adjustable, 2 to 30 psi.

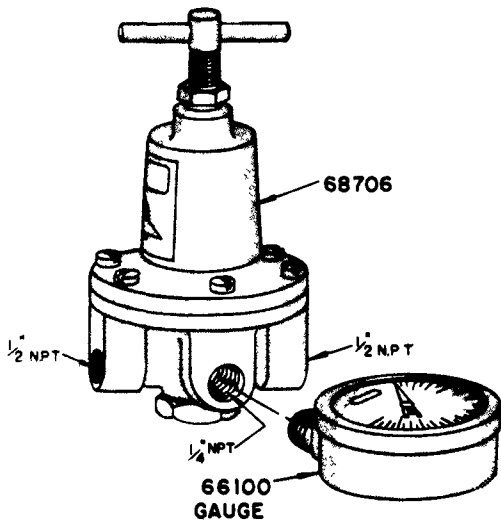
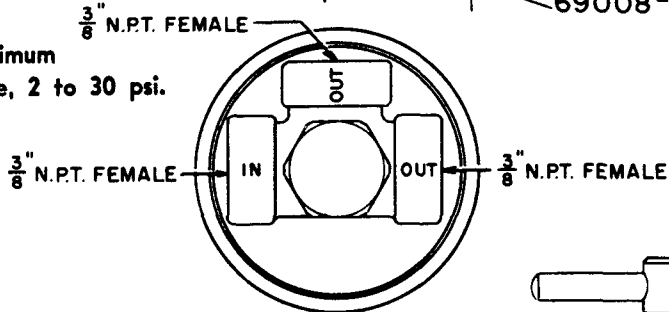
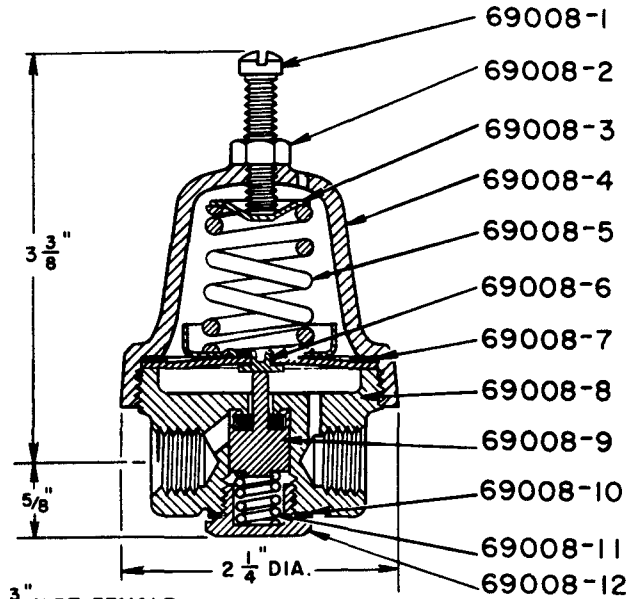

82965 FLUID PRESSURE REGULATOR

Operating Pressure

Primary - 400 psi maximum

Secondary - Adjustable, 0 to 75 psi.

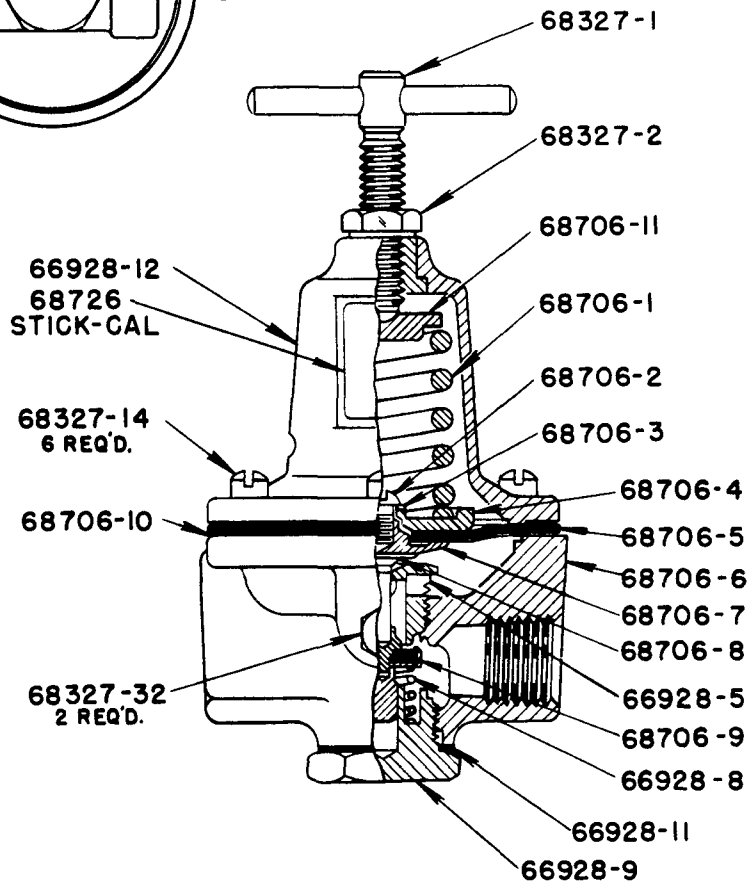

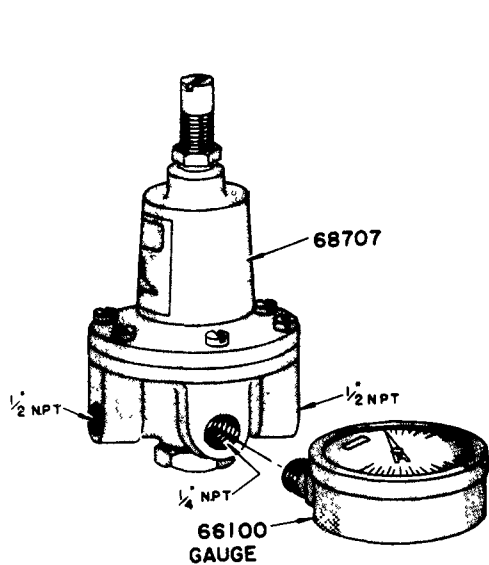

82966 FLUID RELIEF VALVE

Operating Pressure

Primary - 250 psi maximum

Secondary - Adjustable, 0 to 160 psi.

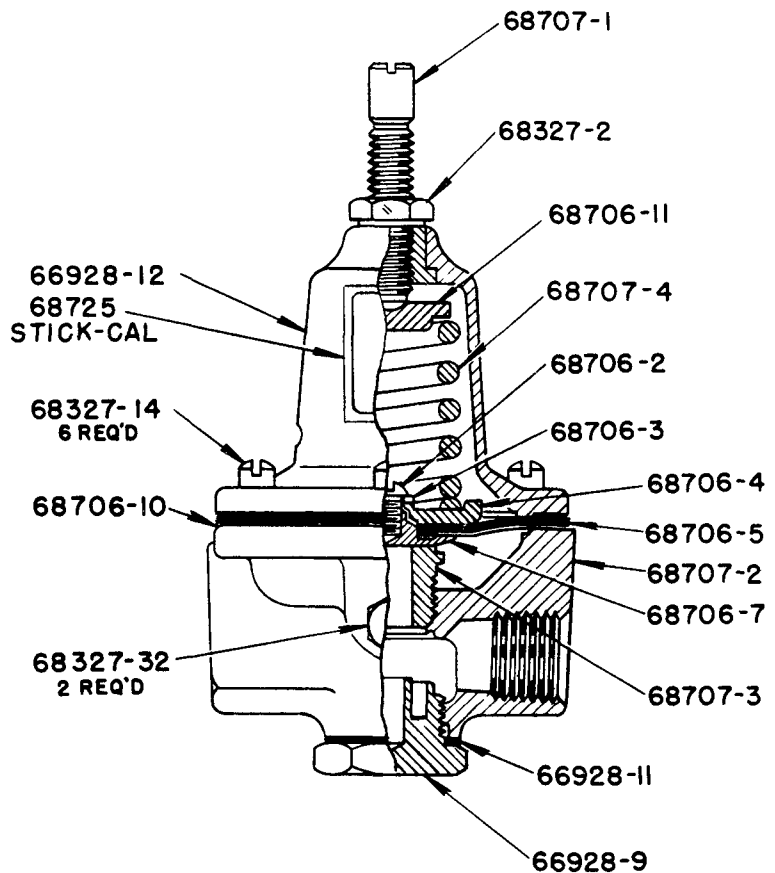

REPAIR PARTS LIST

PART NO.	DESCRIPTION	PART NO.	DESCRIPTION
66100	Pressure Gauge	68706-11	Upper Spring Rest
66928-5	Valve Seat	68707	Fluid Relief Valve
66928-8	Valve Spring	68707-1	Adjusting Screw
66928-9	Valve Guide Plug	68707-2	Body
66928-11	Guide Plug Gasket	68707-3	Valve Seat (Blank)
66928-12	Bonnet	68707-4	Regulating Spring
68327-1	Adjusting Screw	68725	Identification Stick-Cal
68327-2	Lock Nut	68726	Identification Stick-Cal
68327-14	Screw	69008-1	Pressure Screw
68327-32	Pipe Plug	69008-2	Lock Nut
68706	Fluid Pressure Regulator	69008-3	Spring Button
68706-1	Regulating Spring	69008-4	Spring Chamber (Aluminum)
68706-2	Screw	69008-5	Pressure Spring
68706-3	Lockwasher	69008-6	Diaphragm Assembly
68706-4	Lower Spring Rest	69008-7	Diaphragm Gasket
68706-5	Diaphragm	69008-8	Body
68706-6	Body	69008-9	Piston Assembly
68706-7	Valve Body	69008-10	Bottom Plug Gasket
68706-8	Valve Pin	69008-11	Piston Spring
68706-9	Valve	69008-12	Bottom Plug
68706-10	Diaphragm Protector		

RETAIN THIS INFORMATION FOR FUTURE REFERENCE

When ordering Replacement Parts, List Part Numbers, Description, Model Number, and Series Letter.

LINCOLN ST. LOUIS Provides a Distributor Network that stocks Equipment and Replacement Parts.

Repairs by Authorized Service Depts. List furnished upon request.