

MATERIAL STRAINER

"DYNA-SPRAY" SYSTEM

MODELS 68631, 68737 69391, 69459

MODEL 68631

MAXIMUM RECOMMENDED OPERATING PRESSURE 5000 P.S.I.G.

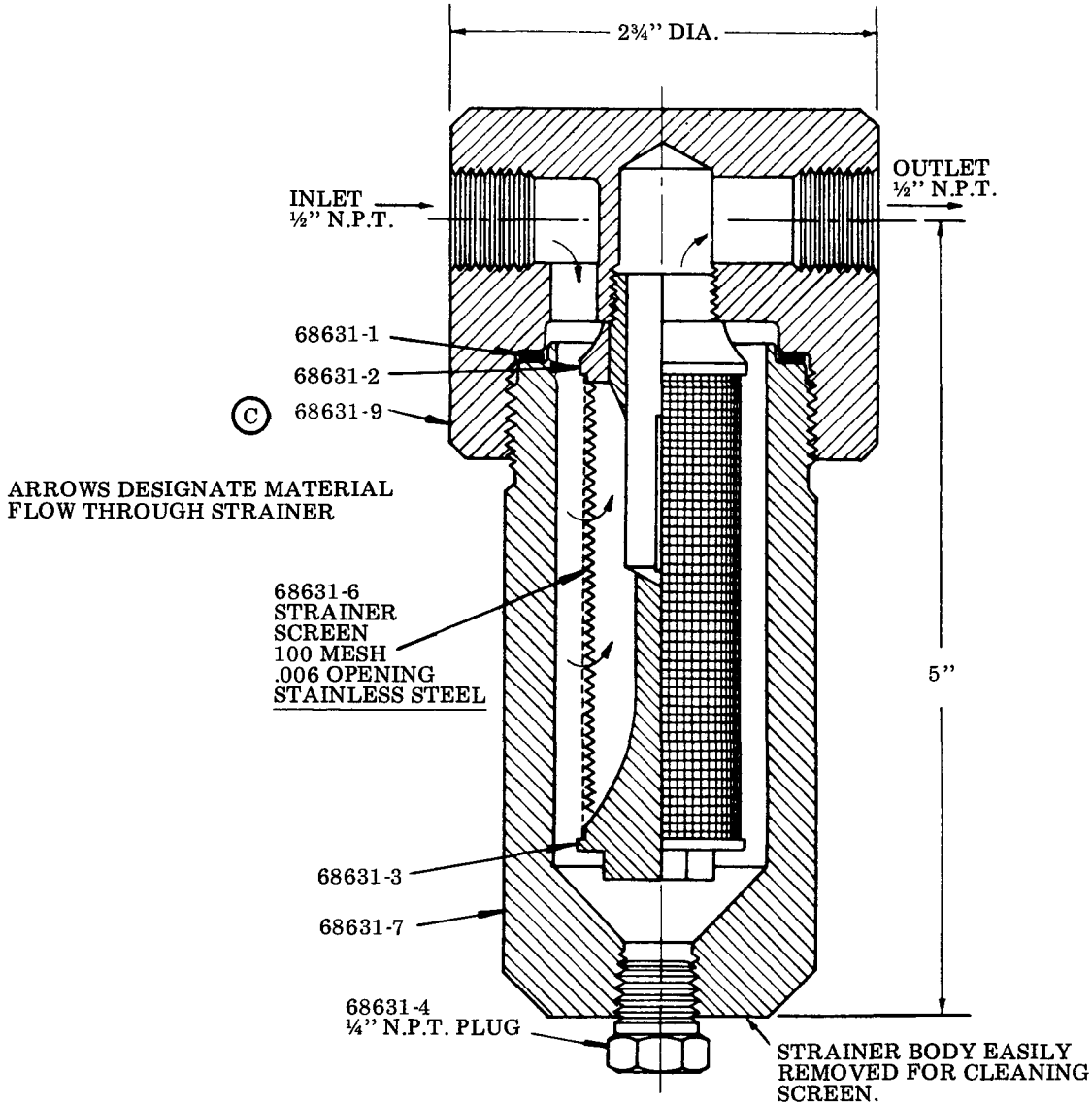

Ⓒ Indicates Change

REPAIR PARTS LIST

PART NO.	DESCRIPTION	PART NO.	DESCRIPTION
68631-1	Viton Gasket	68631-6	Strainer Screen
68631-2	Screen Guide Bushing	68631-7	Strainer Body
68631-3	Screen Support Body	68631-9	Strainer Head
68631-4	1/4" Pipe Plug		

LINCOLN ST. LOUIS
4010 GOODFELLOW BLVD • ST. LOUIS, MO 63120 • (314) 383 5900



A DIVISION OF
McNEIL
CORPORATION

SECTION - **A52**
PAGE - **9B**

MODELS 68737, 69391 AND 69459 HIGH PRESSURE STRAINER
MAXIMUM RECOMMENDED OPERATING PRESSURE 5000 P.S.I.G.

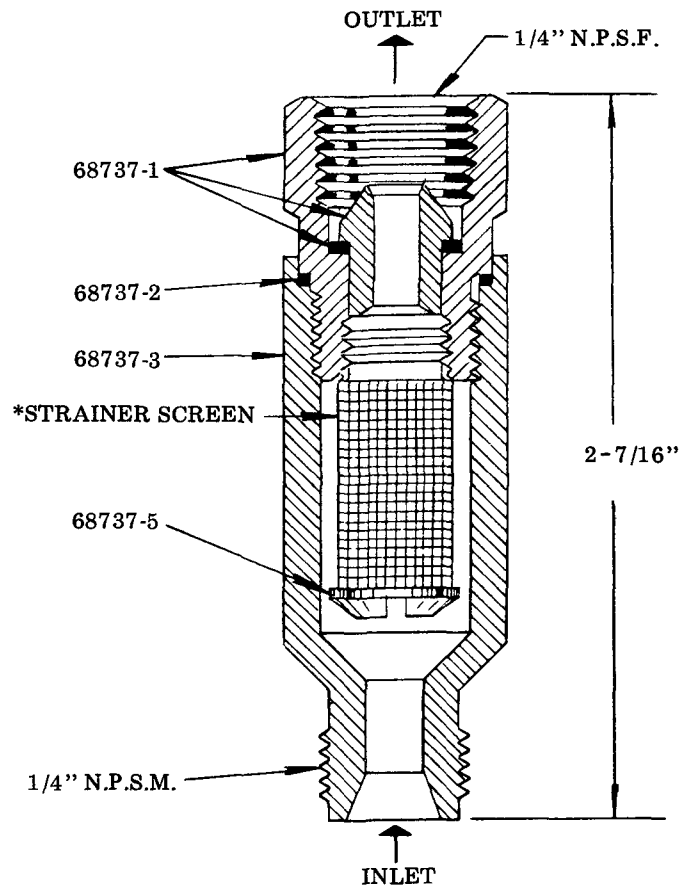

ARROWS DESIGNATE MATERIAL FLOW THROUGH STRAINER

REPAIR PARTS LIST

MODEL NO.	PART NO.	DESCRIPTION
	68737-1	Cap, Seat Insert & Gasket Assembly
	68737-2	Nylon Gasket
	68737-3	Stainless Steel Body
	68737-5	Stainless Steel Screen Support
*68737	68737-4	100 Mesh Stainless Steel Strainer Screen
*69391	69391-1	50 Mesh Stainless Steel Strainer Screen
*69459	69459-1	200 Mesh Stainless Steel Strainer Screen

RETAIN THIS INFORMATION FOR FUTURE REFERENCE

When ordering replacement parts, list: Part Number, Description, Model Number, and Series Letter.
 LINCOLN ST. LOUIS provides a Distributor Network that stocks equipment and replacement parts.
 A list of Authorized Service Departments will be furnished upon request.