

OWNER/OPERATOR MANUAL

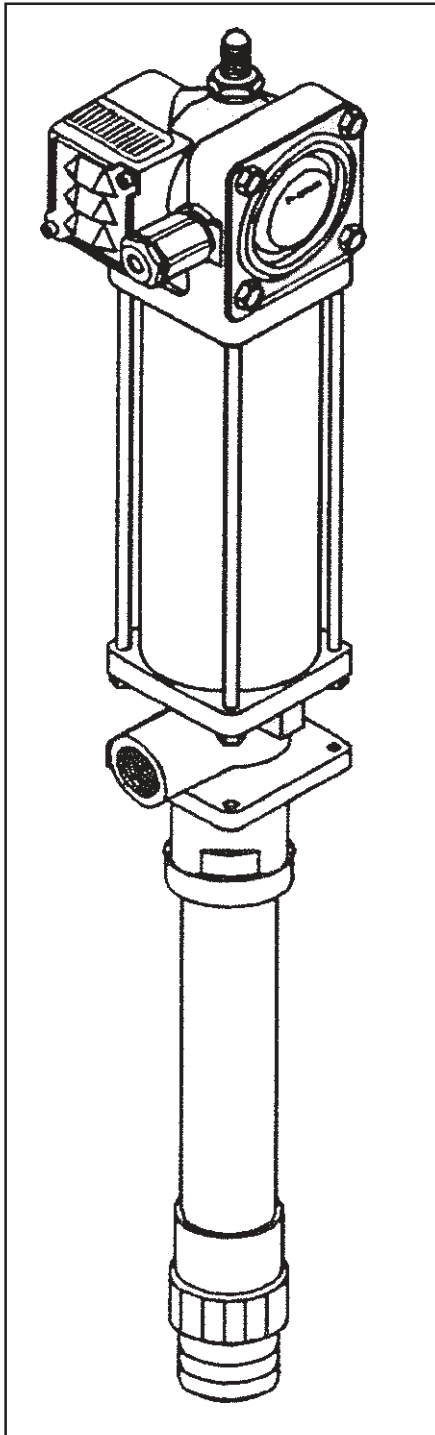

SPECIFICATIONS

Airmotor effective dia. in.	2.5
Stroke, in.	4.8
Air inlet	1/4 NPT
Material outlet	1/2 NPT
Fluid to air pressure ratio	5:1
Delivery output, G.P.M.	5
Delivery in cubic inches per cycle	7.9
Suction head, ft. of oil primed pump	25
Width	4.25"
Depth	3.88
Height	24.88
Minimum air pressure	40 p.s.i.
Maximum air pressure	200 p.s.i.
Max output pressure	1000 p.s.i.
Noise level @ 120 psig	83 dBA

DESCRIPTION

Model 84933 is a stub pump designed to pump low and medium viscosity materials. The pump is self-priming and develops a suction head up to 25 ft. of oil after priming.

OWNER/OPERATOR RESPONSIBILITY

It is the owners/operators responsibility to properly use and maintain this equipment.

The instructions and warnings contained in this manual shall be read and understood by the owner/operator prior to operating this equipment. If an owner/operator does not understand English, the contents of this manual shall be explained in the owners/ operators native language to assure the owner/operator comprehends.

It is the owners/operators responsibility to maintain the legibility of all warning and instruction labels.

The owner/operator shall retain this manual for future reference to important warnings, operating and maintenance Instructions.

SAFETY INFORMATION

Read and understand all warnings, cautions and instructions before operating this equipment. Extreme caution should be used when operating this equipment as personal injury and/ or property damage can result from equipment misuse. Adequate personal protection is recommended to prevent splashing of material on the skin or in the eyes. ALWAYS disconnect air coupler from pump when the pump is not being used.

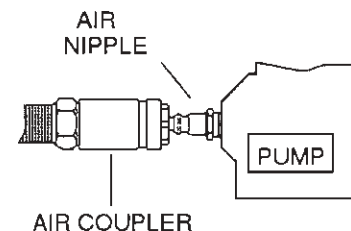

WARNING

FAILURE TO HEED THE FOLLOWING WARNINGS INCLUDING MISUSE, OVER PRESSURIZING, MODIFYING PARTS, USING INCOMPATIBLE CHEMICALS AND FLUIDS, OR USING WORN OR DAMAGED PARTS, MAY RESULT IN EQUIPMENT DAMAGE AND/OR SERIOUS PERSONAL INJURY, FIRE, EXPLOSION, OR PROPERTY DAMAGE.

- Do not exceed the stated maximum working pressure of the pump or of the lowest rated component in your system.
- Do not alter or modify any part of this equipment.
- Do not operate this equipment with combustible gas.
- Do not attempt to repair or disassemble the equipment while the system is pressurized.
- Make sure all fluid connections are securely tightened before using this equipment.
- Always read and follow the fluid manufacturer's recommendations regarding fluid compatibility, and the use of protective clothing and equipment.
- Check all equipment regularly and repair or replace worn or damaged parts immediately.
- Never point the dispensing valve at any part of the body or at another person.
- Never try to stop or deflect material from dispensing valve or leading connection or component with your hand or body.
- Always check equipment for proper operation before each use, making sure safety devices are in place and operating properly.
- Always follow the pressure relief procedure after shutting off the pump, when checking or servicing any part of the system, and when installing, cleaning or changing any part of the system.

INSTALLATION

Typical bulk tank and drum system hookups are shown and described as follows only as a guide in selecting and installing a system. Contact a Lincoln factory representative for assistance in designing a system for a specific requirement.

TYPICAL SYSTEM HOOKUP

See Figure (1)- Determine the tank or drum system for your requirement.

See Figure (2). Obtain an air line filter/ regulator/lubricator to use with the inlet air supply and the correct sized air and fluid lines/hoses with any required reducers, connectors and accessories.

Clean/flush the supply lines, hoses, reducers, connectors and accessories with mineral spirits or oil based solvent to purge any contaminants such as dirt, moisture, or metal shavings that could damage the pump or system components. Blow dry with air.

CAUTION

The pump was tested in lightweight oil which was left in to protect the pump from corrosion. Flushing the pump before connecting it to the system might be desired to prevent possible contamination of the fluid you are pumping.

WARNING

To reduce the risk of injury from splashing or static sparking when flushing the pump with solvents, always hold a metal part of the dispensing valve firmly to the side of a grounded metal pail and operate pump at lowest possible fluid pressure.

Clean/flush the pump with mineral spirits or oil based solvents if necessary.

Assemble the cleaned pump and supply line together with any required accessory (low level cut-off).

Mount the assembled pump to the tank or drum.

Connect the material output line/hose to the pump.

Connect the air regulator to the pump.

Make sure all connections are securely tightened.

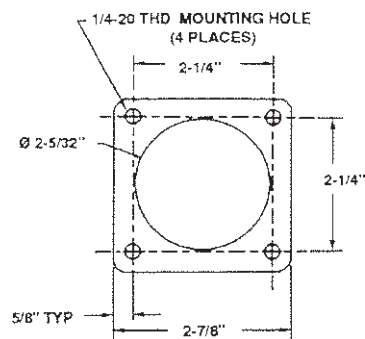

PRESSURE RELIEF PROCEDURE

Always perform this procedure when the pump is shut off and before checking, servicing, installing, cleaning or repairing any part of this system.

Perform the following procedure:

- A. Disconnect the air supply to the Pump.
- B. Point the dispensing valve away from yourself and others.
- C. Open the dispensing valve into an appropriate container until the pressure is relieved.

If the above procedure does not relieve the pressure, the dispensing valve or hose may be restricted. To relieve the pressure, very slowly loosen the hose end coupling. Then loosen completely and clear the dispensing valve and/or hose.

OPERATION BEFORE USING PUMP

Prior to operation or maintenance a visual inspection shall be made. Check pump system for leaks, worn or missing parts.

Any pump that appears to be damaged in any way, is badly worn or operates abnormally shall be removed from use until repairs are made. Contact a factory authorized service center for repairs.

If overpressurizing of the equipment is believed to have occurred, contact a factory authorized service center for inspection of the pump.

Annual inspection by a factory authorized service center is recommended.

DISASSEMBLY



To prevent personal injury, perform PRESSURE RELIEF PROCEDURE before and after operating the pump.

NOTE

If complete disassembly is required, order the repair kit and replace ALL gaskets, o-rings and packings.

- A. Remove valve cap (11470), trip rod pin (11472) and trip collar (11471).
- B. Remove four nuts (51009) from tie rods (241512).
- C. Unscrew trip sleeve (11947) from the trip rod (245398) and lift air valve casting (237562) off of air cylinder (61447).
- D. Remove packing nut (11904) -3 and packing cap (11905) from air valve casting. Remove the packing (34110) and packing washer (48237).
- E. Remove four screws (236868) and cover (236286) with the O-ring (34158).

- F. Remove four screws (236869), toggle plate (91331), trio shoe (11475) and trip sleeve (11947).
- G. Remove four valve seat screws (236870), four springs (55138), valve guide plate (45605) with two springs (56038), two balls (66010) and valve slide and seat with gasket (83063).
- H. Unscrew trip rod packing nut (245425) from air valve casting and remove all packing and gaskets.
- I. Unscrew foot valve body (241517) and pump tube (245511) from outlet casting (245401).
- J. Remove air cylinder (61447) and air passage tube (62383) from out-let casting.
- K. Place wrench on piston seat (12758) and connecting rod (16636). Remove piston seat (12578) and piston (16635) with two packings (261077) and stop (12337).
- L. Place wrench on piston bolt (245424) and piston rod (241510) and remove piston bolt (245424), piston packing (34090), two wash-ers (48212) and trip rod (245398).
- M. Unscrew gland packing nut (245426) from outlet casting and remove all gland seal parts.

USING PUMP

To start pump, turn on the main air supply. Slowly open the air regulator. Regulate air pressure from 20-40 psig and throttle to prime pump. Open the dispensing valve to allow air to be purged from the system. Allow pump to cycle until fluid without air pockets flows from dispensing valve, then close dispensing valve.

After pump is primed, adjust air pressure to achieve a smooth flow of fluid from the dispensing valve. Do not allow pump to operate when out of material. Pump will accelerate quickly and run too fast, resulting in costly damage to the pump.

If the pump accelerates quickly or is running too fast, stop it immediately. Check the fluid supply and refill it if necessary. Prime the pump to remove all air from the system, or flush the pump and relieve pressure.

In a circulating system, the pump runs continuously and slows down or speeds up as supply demands, until the air supply is shut off.

In a direct supply system, with adequate air pressure supplied to the motor, the pump starts when the gun or dispensing valve is opened and stalls against pressure when it is closed

Use the air regulator to control pump speed and fluid pressure. Always use the lowest pressure required to achieve the desired results. Higher pressures will cause pump packings to wear prematurely.

MAINTENANCE



To prevent personal injury, perform PRESSURE RELIEF PROCEDURE before and after operating the pump and before performing any maintenance.

LUBRICATION

An air line filter/regulator/lubricator is recommended for use with your Lincoln pump to remove harmful dirt and moisture from your compressor air supply, and to provide automatic motor lubrication.

If an air line lubricator is not used, the following procedure should be performed daily:

- A. Disconnect air coupler from air fitting.
- B. Fill air coupler with NO. 10 SAE motor oil and reconnect to air fitting.
- C. Operate pump to distribute lubricant.

MATERIAL RESTRICTION PREVENTION

Flush the system as required with a compatible solvent to prevent material buildup when pumping material that dries or hardens.

CORROSION PREVENTION



To reduce the risk of injury from splashing or static sparking when flushing the pump with solvents, always hold a metal part of the dispensing valve firmly to the side of a grounded metal pail and operate pump at lowest possible fluid pressure.

To prevent water or air corrosion, never leave the pump filled with water or air. Flush the pump first with a compatible solvent and then again with mineral spirits or oil based solvent.

TROUBLESHOOTING

If the following procedures do not correct the problem, contact a factory authorized service center. When submitting equipment to be repaired, be sure to state the nature of the problem and indicate if a repair cost estimate is required.

PROBLEMS

AIRMOTOR DOES NOT OPERATE.

- Check air supply to pump.
- Check trip rod pin (11472), trip rod (245938) and toggle assembly (91331) for break-age or loose parts.

AIR SEEPAGE FROM AIR EXHAUST WHILE PUMP IS NOT OPERATING

- Replace valve slide and seat and gasket (83063), trip rod packing (236835) and gasket (236616).

LOSS OF PRESSURE, VOLUME OR CONTINUOUS OPERATION OF PUMP WHEN NOT IN NORMAL USE.

- Clean piston seat and ball foot valve.
- If worn or damaged, replace piston (16635), piston seat (12758) and piston packings (261077).
- Check inside diameter of pump tube (241511). If scored, replace pump tube.

EXCESSIVE AMOUNT OF AIR IN LUBRICANT OR EXCESSIVE AMOUNT OF LUBRICANT COMING FROM AIR EXHAUST.

NOTE

Some lubricant exhausts with air normally.

- Replace U-cup (245427), O-ring (245429) and quad-ring (245428).

ASSEMBLY

To reassemble, perform DISASSEMBLY procedures in reverse.

SERVICE PARTS

Contact your nearest authorized Lincoln Service Center for service parts and repair.

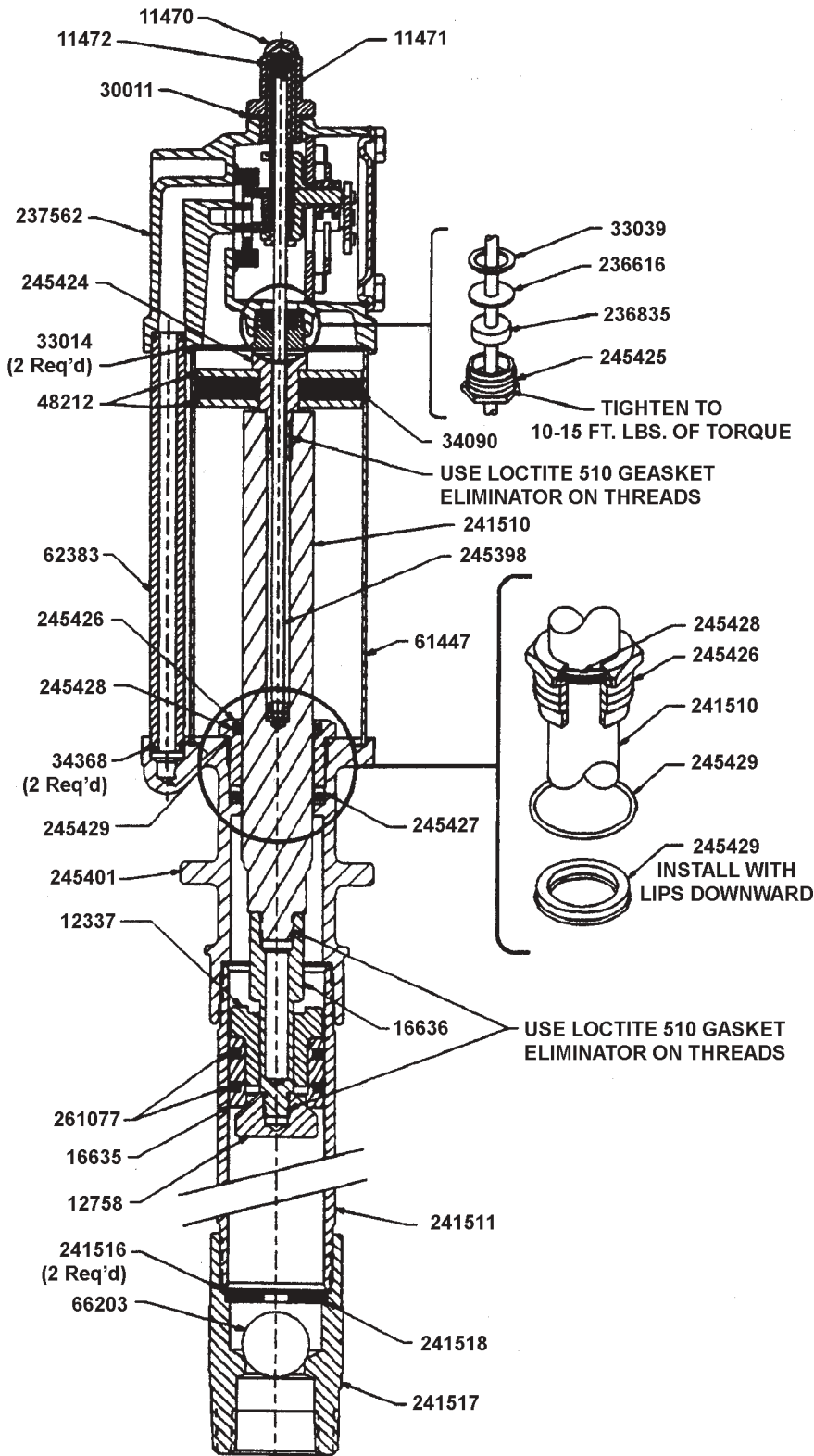

PARTS	QTY	DESCRIPTION
11470	1	Valve cap
11471	1	Trip collar
*11472	1	Trip rod pin
11475	1	Trip shoe
11904	1	Packing nut
11905	1	Packing cap
11947	1	Trip sleeve
12337	1	Spring stop
*12758	1	Piston seat
*16635	1	Piston
16636	1	Connecting rod
*30003	1	Packing nut gasket
*30011	1	Valve cap gasket
*33014	2	Gasket
*33039	1	Gasket
34090	1	Air piston packing
*34110	1	Packing (Nitrite)
*34158	1	O-ring (Neoprene)
*34368	2	O-ring (Nitrite)
*38162	1	Valve gasket
45605	1	Valve guide plate
48212	2	Air piston washer
48237	1	Packing washer
51009	4	Nut
55138	4	Spring
*56038	2	Spring
61447	1	Air cylinder
62383	1	Air passage tube
*66010	2	Steel ball
66203	1	Steel ball
83063	1	Valve slide 8 seat
91331	1	Toggle assembly
236286	1	Cover
236615	1	Muffler cover
*236616	1	Gasket
236833	1	Muffler
*236835	1	Packing (Nitrite)
236868	4	Screw
236869	4	Screw
236870	4	Valve seat screw
237562	1	Air valve casting
241510	1	Piston roa
241511	1	Pump tube
241512	4	Tie rod
*241516	2	Pump tube gasket
241517	1	Foot valve body
241518	1	Ball stop
245398	1	Trip rod
245401	1	Outlet casting
245424	1	Piston bolt
245425	1	Trip rod packing nut
245426	1	Gland packing nut
*245427	1	LI-cup
*245428	1	Quad-ring
*245429	1	O-ring
*261077	2	Packing (Nitrite)

* Included in 83071 Repair Kit.

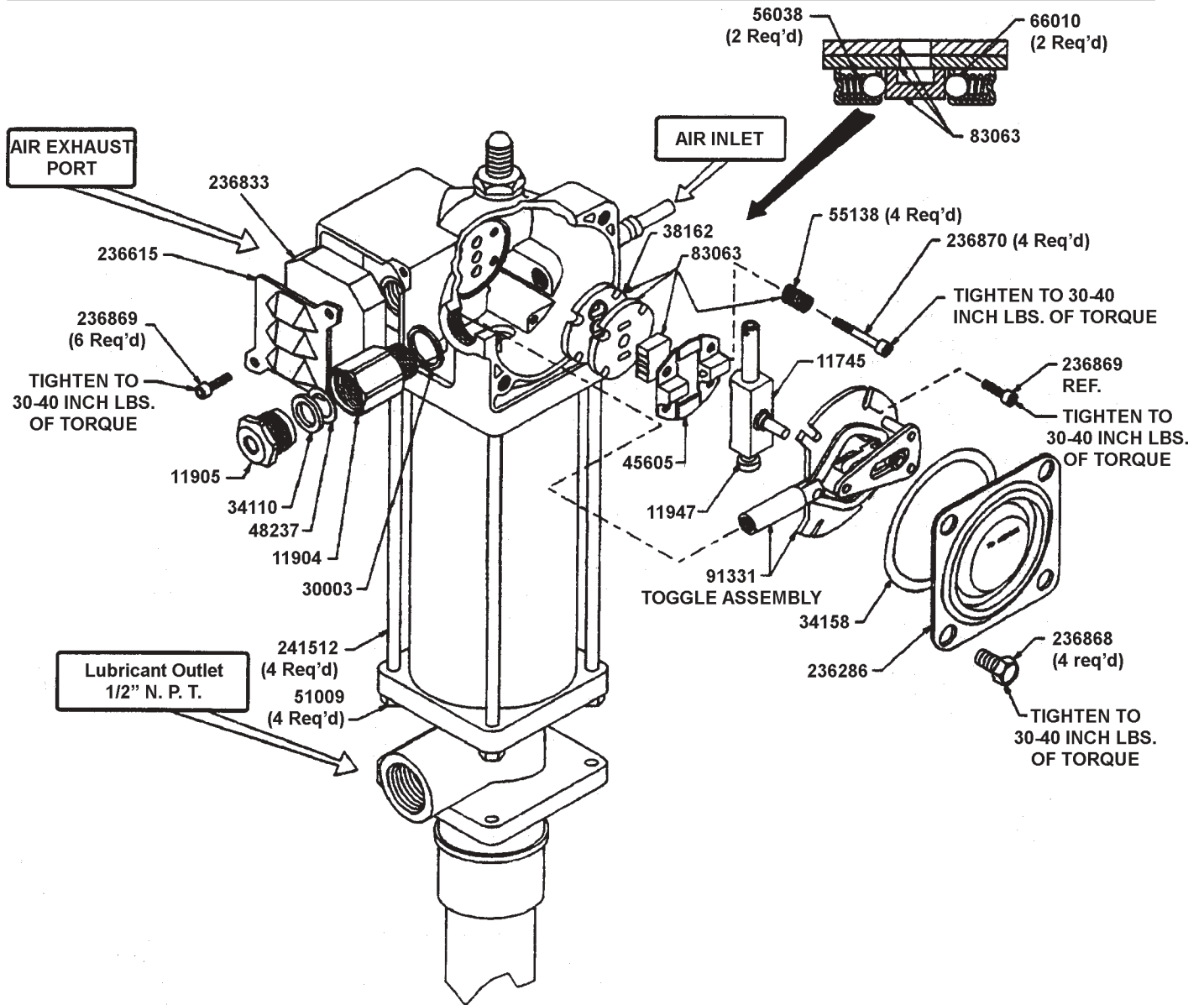

TO LUBRICATE AIR VALVE MECHANISM

- Disconnect air to pump.
- Perform pressure relief procedure.
- Remove four cover screws, cover plate and cover plate gasket.
- Pack grease behind toggle plate. Use approx. 2-1/2 ounces of n.l.g.i. no. 1 (light grade) water repellent grease 220, sp2.
- If toggle plate has been removed from air valve casting, pack cavity with grease before replacing toggle plate.
- Replace cover plate gasket, cover plate and cover screws. Tighten to prevent air leaks.
- Periodic inspection of parts at least once a year is advised.

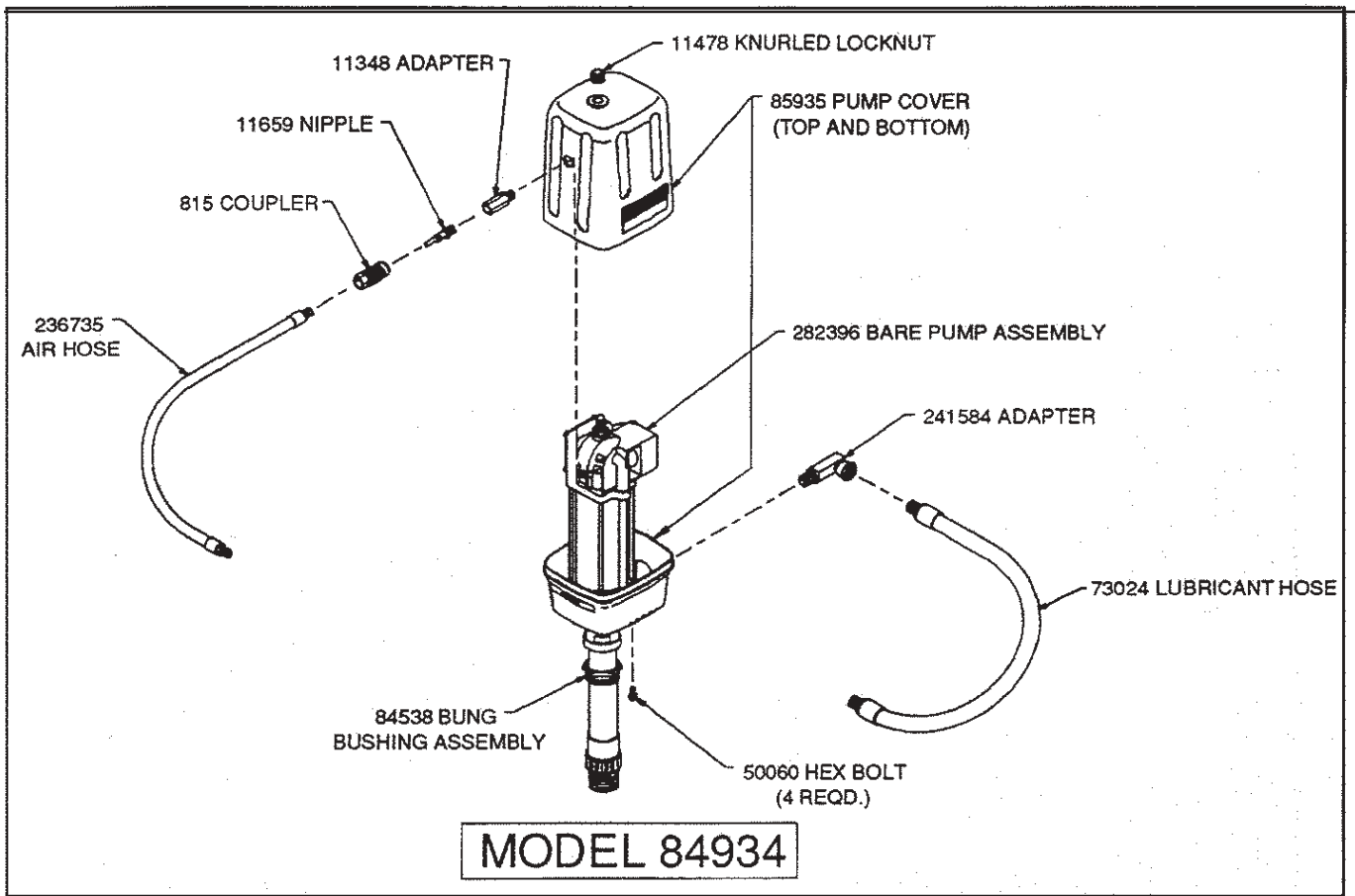

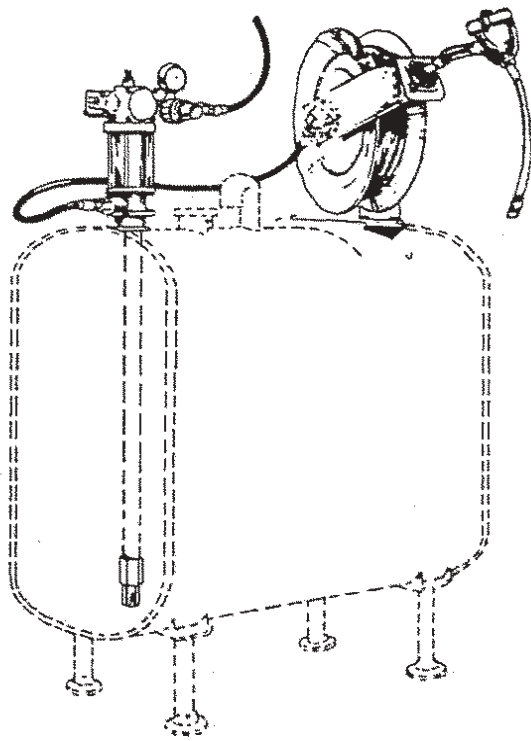

NOTE

When pumping from a bulk tank, use a 82439 low level cutoff to maintain prime and prevent air from being pumped through the meter when the tank is empty.

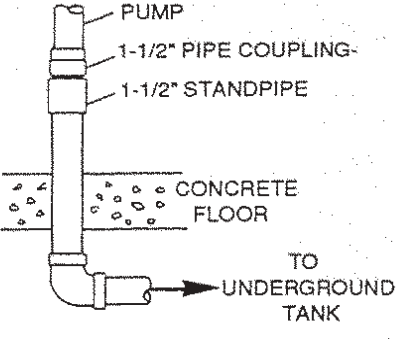
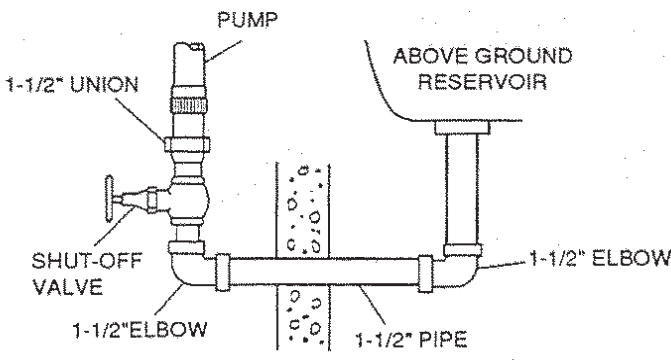
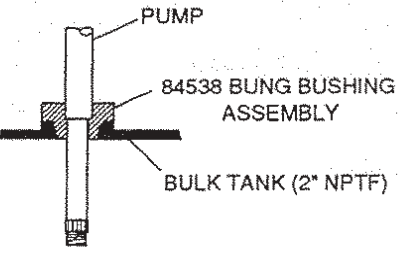
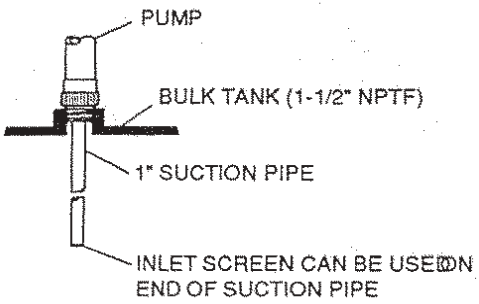
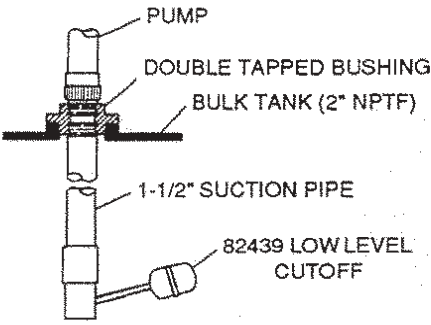
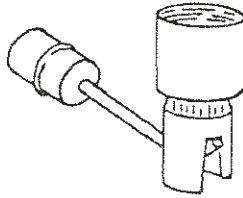

FIGURE (1) TYPICAL INSTALLATIONS

MODEL 84765 (1" NPT)
FOOT VALVE



MODEL 84946 (1" NPT)
MODEL 82439 (1-1/2" NPT)
LOW LEVEL CUTOFF



MODEL 84940
WALL MOUNT BRACKET KIT

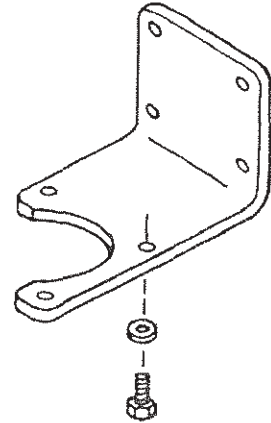

MODEL 84945 SUCTION KIT
FOR 16 OR 55 GALLON DRUMS

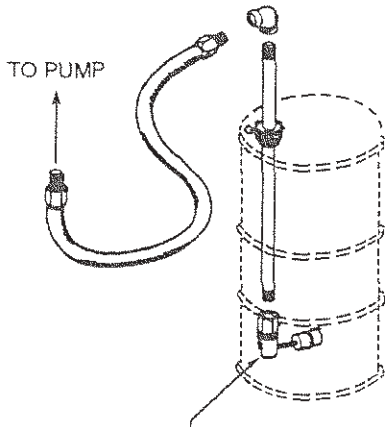

MODEL 84600
LOW COMPENSATOR KIT

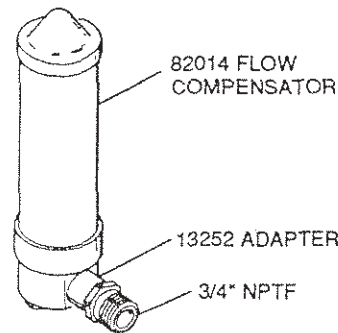

MODEL 84538 (2" NPTF)
BUNG BUSHING ASSEMBLY

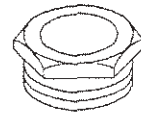

84946 LOW LEVEL CUTOFF IS NOT PART OF 84945
AND MUST BE ORDERED SEPARATELY.

FILTER-REGULATOR AND GAUGE-LUBRICATOR						
MODEL	PIPE SIZE	A	B	C	D	WEIGHT
83387-4	1/4"	8-3/4"	7-5/8"	5-3/8"	4-1/8"	5.5 LBS
83387-6	3/8"	8-3/4"	7-5/8"	5-3/8"	4-1/8"	5.5 LBS
83387-8	1/2"	10-3/4"	8-1/8"	5-3/4"	4-3/4"	8.5 LBS

FIGURE (2) ACCESSORIES

LIMITED WARRANTY

Lincoln warrants that lubrication equipment, materials dispensing equipment and other related equipment manufactured by it will be free from defects in material and workmanship during the one (1) year following the date of purchase. If equipment proves to be defective during this warranty period, it will be repaired or replaced without charge, provided that factory examination indicates the equipment to be defective. To obtain repairer replacement, it must be shipped, transportation charges prepaid, with proof of date of purchase to a Lincoln authorized Warranty and Service Center, within the one (1) year following the date of purchase.

This warranty is extended to the original retail purchaser only. This warranty does not apply to equipment damaged from accident, overload, abuse, misuse, negligence, faulty installation or abrasive or corrosive materials, or to equipment repaired or altered by anyone not authorized by Lincoln to repair or alter the equipment. This warranty applies only to equipment installed and operated according to the recommendations of Lincoln or its authorized field personnel. No other express warranty applies to lubrication equipment, materials dispensing equipment, and other related equipment manufactured by Lincoln.

ANY IMPLIED WARRANTIES applicable to lubrication equipment, materials dispensing equipment, and other related equipment manufactured by Lincoln INCLUDING THE WARRANTIES OF MERCHANTABILITY AND FITNESS FOR A PARTICULAR PURPOSE, WILL LAST ONLY FOR ONE (1) YEAR FROM THE DATE OF PURCHASE. SOME STATES DO NOT ALLOW LIMITATIONS ON HOW LONG AN IMPLIED WARRANTY LASTS, SO THE ABOVE LIMITATION MAY NOT APPLY TO YOU.

In no event shall Lincoln be liable for incidental or consequential damages. The liability of Lincoln on any claim for loss or damage arising out of the sale, resale, or use of lubrication equipment, materials dispensing equipment, and other related equipment shall in no event exceed the purchase price. SOME STATES DO NOT ALLOW THE EXCLUSION OR LIMITATION OF INCIDENTAL OR CONSEQUENTIAL DAMAGES, SO THE ABOVE LIMITATION OR EXCLUSION MAY NOT APPLY TO YOU.

THIS WARRANTY GIVES YOU SPECIFIC LEGAL RIGHTS AND YOU MAY ALSO HAVE OTHER RIGHTS WHICH VARY FROM STATE TO STATE.

Americas:
One Lincoln Way
St. Louis, MO 63120-1578
USA
Phone +1.314.679.4200
Fax +1.800.424.5359

Europe/Africa:
Heinrich-Hertz-Str 2-8
D-69183 Walldorf
Germany
Phone +49.6227.33.0
Fax +49.6227.33.259

Asia/Pacific:
25 Int'l Business Park
#01-65 German Centre
Singapore 609916
Phone +65.562.7960
Fax +65.562.9967

© Copyright 2003
Printed in USA

Web site:
www.lincolnindustrial.com