

1:1 RATIO, OUTPUT - 15 CU. IN./CYL.
MIN. AIR PRESSURE - 20 PSI
MAX. AIR PRESSURE - 200 PSI
MAX. OUTPUT PRESSURE - 200 PSI

OWNERS MANUAL

IT IS THE RESPONSIBILITY OF THE OWNER AND/OR OPERATOR TO PROPERLY USE AND MAINTAIN THIS EQUIPMENT. CAREFULLY READ AND UNDERSTAND THE INSTRUCTIONS AND WARNINGS IN THIS MANUAL BEFORE OPERATING THIS EQUIPMENT.

If the operator is not fluent in English, the instructions and warnings shall be read and discussed in the operator's native language, making sure the operator comprehends the contents.

This equipment complies with OSHA Standards where applicable.

WARNING

DO NOT exceed the stated maximum working pressure of the pump or of the lowest rated component in your system.

DO NOT alter or modify any part of this equipment.

DO NOT operate this equipment with combustible gas.

DO NOT attempt to repair or disassemble the equipment while the system is pressurized.

TIGHTEN all fluid connections securely before using this equipment.

ALWAYS read and follow the fluid manufacturer's recommendations regarding fluid compatibility, and the use of protective clothing and equipment.

CHECK all equipment regularly and repair or replace worn or damaged parts immediately.

IMPORTANT: Failure to heed these warnings including misuse, overpressurizing, modifying parts, using incompatible chemicals and fluids, or using worn or damaged parts, may result in equipment damage and/or serious personal injury, fire, explosion, or property damage.

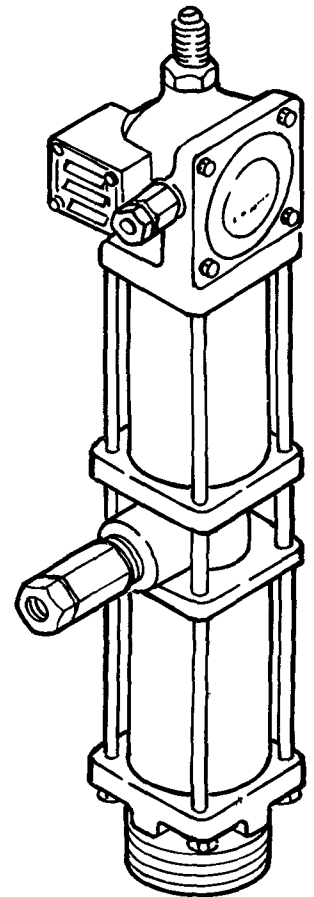

CONTENTS

	PAGE
Safety Instructions	2
Inspection Instructions	2
Damaged Pumps	2
Installation	2
Operation	3
Maintenance	3
General Dimensions	3
Disassembly Procedure	4
Parts Breakdown	4-6
Service Parts	7
Troubleshooting Chart	7
Accessories	7
Warranty	8

This manual contains **IMPORTANT WARNINGS** and **INSTRUCTIONS** READ AND RETAIN FOR REFERENCE

SAFETY INSTRUCTIONS

For professional use only. Observe all warnings. Read and understand all instructions before operating equipment. Extreme caution should be used when operating this equipment as personal injury and/or property damage can result from equipment misuse. Adequate protection is recommended to prevent splashing of material onto the skin or into the eyes.



WARNING

NEVER point the dispensing valve at any part of the body or at another person.



WARNING

NEVER try to stop or deflect material from dispensing valve or leaking connection or component with your hand or body.



WARNING

ALWAYS check equipment for proper operation before each use, making sure safety devices are in place and operating properly. **DO NOT** alter or modify any part of the equipment as this may cause a malfunction and result in serious bodily injury.



WARNING

ALWAYS follow the pressure relief procedure after shutting off the pump, when checking or servicing any part of the system, and when installing, cleaning or changing any part of the system.



WARNING

ALWAYS read and follow the fluid and solvent manufacturer's recommendations regarding the use of protective clothing and equipment.



WARNING

PRESSURE RELIEF PROCEDURE

To reduce the risk of serious bodily injury, including splashing into the eyes or onto the skin, always follow this procedure: **Whenever you shut off the pump, when checking or servicing any part of the system, and when installing, cleaning or changing any part of the system.**

1. Disconnect air to the pump.
2. Point the dispensing valve away from yourself and others.
3. Open the dispensing valve into an appropriate container until pressure is relieved.

If you suspect that the dispensing valve or hose is completely clogged or that pressure has not been fully relieved after following the above procedure, **VERY SLOWLY** loosen the hose end coupling to relieve pressure gradually, then loosen completely. Now clear the valve or hose.

INSPECTION INSTRUCTIONS

If overpressurizing of the equipment is believed to have occurred, contact the factory authorized warranty and service center nearest you for inspection of the pump.

Specialized equipment and knowledge is required for repair of this pump. Contact the factory authorized warranty and service center nearest you for repair or adjustments other than maintenance specified in this manual.

Annual inspection by the factory authorized warranty and service center nearest you is recommended.

A list of factory authorized warranty and service centers is available upon request.

DAMAGED PUMPS

Any pump that appears to be damaged in any way, is badly worn or operates abnormally shall be removed from use until repairs are made. Contact the factory authorized warranty and service center nearest you for repairs.

INSTALLATION

The typical installation shown is only a guide for selecting and installing system components. Contact your Lincoln representative for assistance in designing a system to suit your specific needs.

An air line filter/regulator/lubricator is recommended for use with your Lincoln pump to remove harmful dirt and moisture from the compressed air supply, and to provide automatic lubrication to the air motor.



WARNING

This pump can develop 200 PSI working pressure at 200 PSI maximum incoming air pressure. Be sure that all system equipment and accessories are rated to withstand the maximum working pressure of this pump. **DO NOT** exceed the maximum working pressure of the lowest rated component in the system.

Flush the supply lines and hoses with mineral spirits or oil based solvent and blow dry with air before connecting them to the system. This is to purge any contaminants such as dirt, moisture, or metal shavings that could damage the pump or system components.

The pump was tested in lightweight oil which was left in it to protect the pump from corrosion. Flushing of the pump before connecting it to the system might be desired to prevent possible contamination of the fluid you are pumping.



WARNING

To reduce the risk of injury from splashing or static sparking when flushing the pump with solvents, always hold a metal part of the dispensing valve firmly to the side of a grounded metal pail and operate pump at lowest possible fluid pressure.

OPERATION

To start the pump, turn on the main air supply. Slowly open the air regulator until the pump runs smoothly. Open the dispensing valve to allow air to be purged from the system. Allow pump to cycle until fluid without air pockets flows from dispensing valve, then close dispensing valve.

In a direct supply system, with adequate air pressure supplied to the air motor, the pump starts when the dispensing valve is opened and stalls against pressure when dispensing valve is closed.

Use the air regulator to control pump speed and fluid pressure. Always use the lowest pressure required to achieve the desired results. Higher pressures will cause pump packings to wear prematurely.

WARNING

To reduce the risk of serious bodily injury or property damage, NEVER exceed the maximum air or fluid working pressure of the lowest rated system component.

If the pump accelerates rapidly or is running too fast, stop it immediately. Check the fluid supply and refill if necessary. Prime the pump to remove all air from the system or flush the pump and relieve pressure.

WARNING

Water or even moist air can cause pump to corrode. To help prevent corrosion, NEVER leave the pump filled with water or air. After normal flushing, flush the pump again with mineral spirits or oil based solvent, relieve pressure and leave mineral spirits in the pump. Be sure to follow all steps of the pressure relief procedure warning.

MAINTENANCE

WARNING

To reduce the risk of serious bodily injury, ALWAYS follow the pressure relief procedure warning whenever you stop the pump and before checking or repairing any part of the system.

GENERAL DIMENSIONS

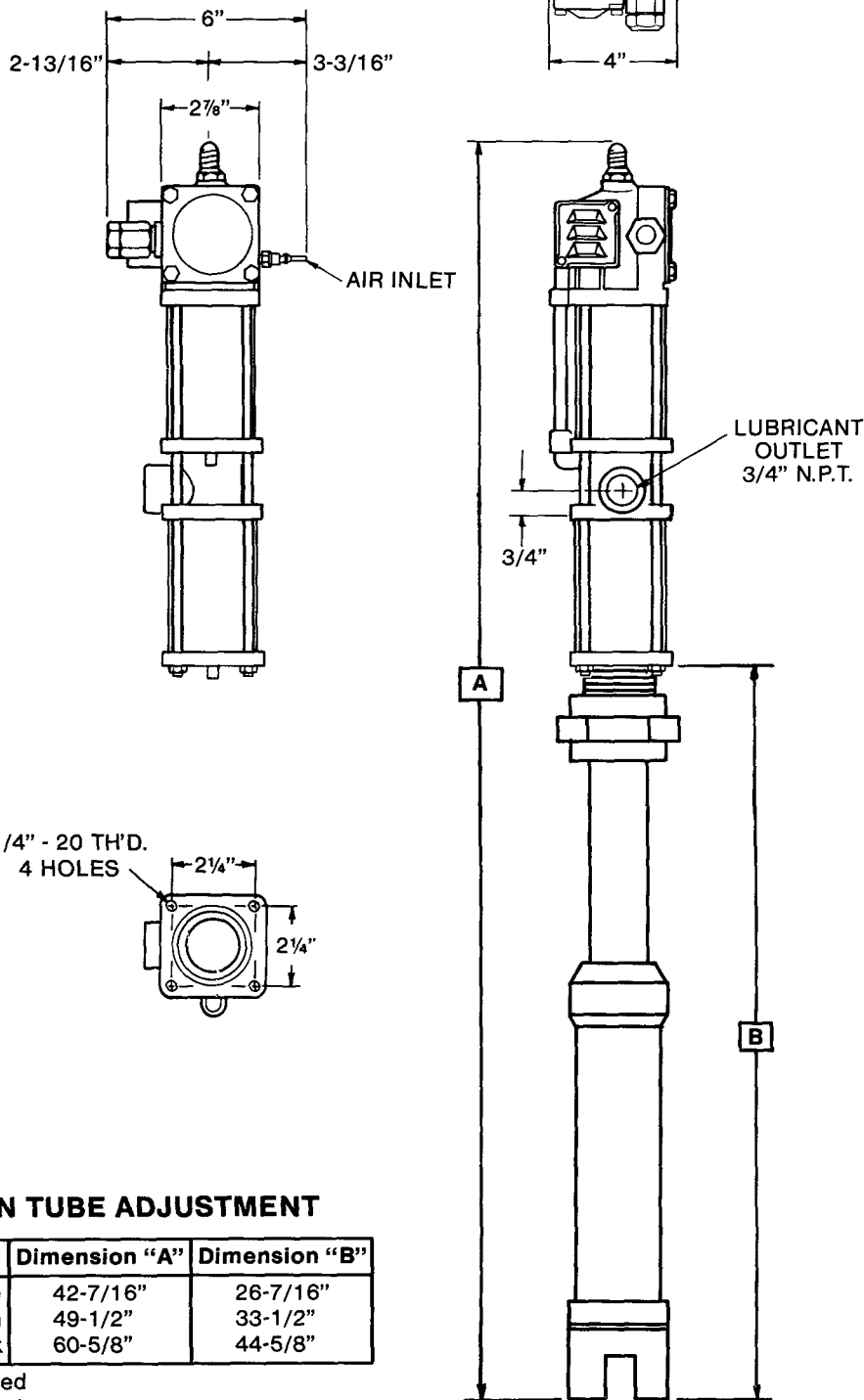

SUCTION TUBE ADJUSTMENT

Drum Size	Dimension "A"	Dimension "B"
* 16 Gal. Drum	42-7/16"	26-7/16"
55 Gal. Drum	49-1/2"	33-1/2"
** 275 Gal. Tank	60-5/8"	44-5/8"

* Fully Collapsed
 ** Fully Extended

DISASSEMBLY PROCEDURE

1. Remove Valve Cap (11470) and Trip Rod Pin (11472).
2. Unscrew four Tie Rod Nuts (51009) from Tie Rods (14490) and lift Air Valve Casting (237562) off of Air Cylinder (61041).
3. Unscrew Spring Retainer (12834) and remove Spring (55231).
4. Remove Packing Nut (11904) and Packing Cap (11905) from Air Valve Casting.
5. Remove four Valve Cover Screws (236868) and Cover (236286).
6. Remove four Toggle Plate Screws (236869), Toggle Plate (91331) and Trip Shoe Assembly (236941).
7. Remove four Valve Seat Bolts (236870), Springs (55138), Valve Guide Plate, and Valve Slide, Seat and Gasket (83063).
8. Unscrew Trip Rod Packing Nut (11476) from Air Valve Casting and remove all packing parts.
9. Remove Inlet Casting (34828) and Suction Tube (84380) Suction Tube from Fluid Cylinder (61040).
10. Remove Air Cylinder and Air Passage Tube (61502) from Outlet Body (41267).
11. Remove Fluid Cylinder and Tie Rods from Outlet Body.
12. Unscrew Air Piston Nut (11337) from Air Piston Bolt (11329) and remove Air Piston Nut, Air Piston Washers (48212) and Air Piston Packing (34090).
13. Extend Piston Rod (14484) out bottom of Outlet Body. Place wrenches on Air Piston Bolt and on wrench flats of Piston Rod and unscrew Piston Rod. Thread Piston Rod through Pump Gland to prevent damaging Gland Packings.
14. Unscrew Nut (51040) from Piston Bolt (14485) and remove Washer (48482) and Check (14487).
15. Place wrenches on Piston Bolt and on wrench flats of Piston Rod and unscrew Piston Rod. Withdraw Trip Rod (237568) from Piston Rod.
16. To reassemble, reverse procedure. Tighten fasteners per torque specifications supplied.

IMPORTANT: To prevent damage to Pump Packings and to help increase Packing life, lube Air Cylinder, Fluid Cylinder and Piston Rod before assembly.

NOTES:

1. Before tightening four Valve Seat Bolts, align the Valve Slide, Seat and Gasket, Valve Seat Gasket (38162) and Air Valve Casting (237562) by placing a rod or ink pen through the center port hole.
2. Start all fasteners by hand to avoid stripping threads when reassembling.

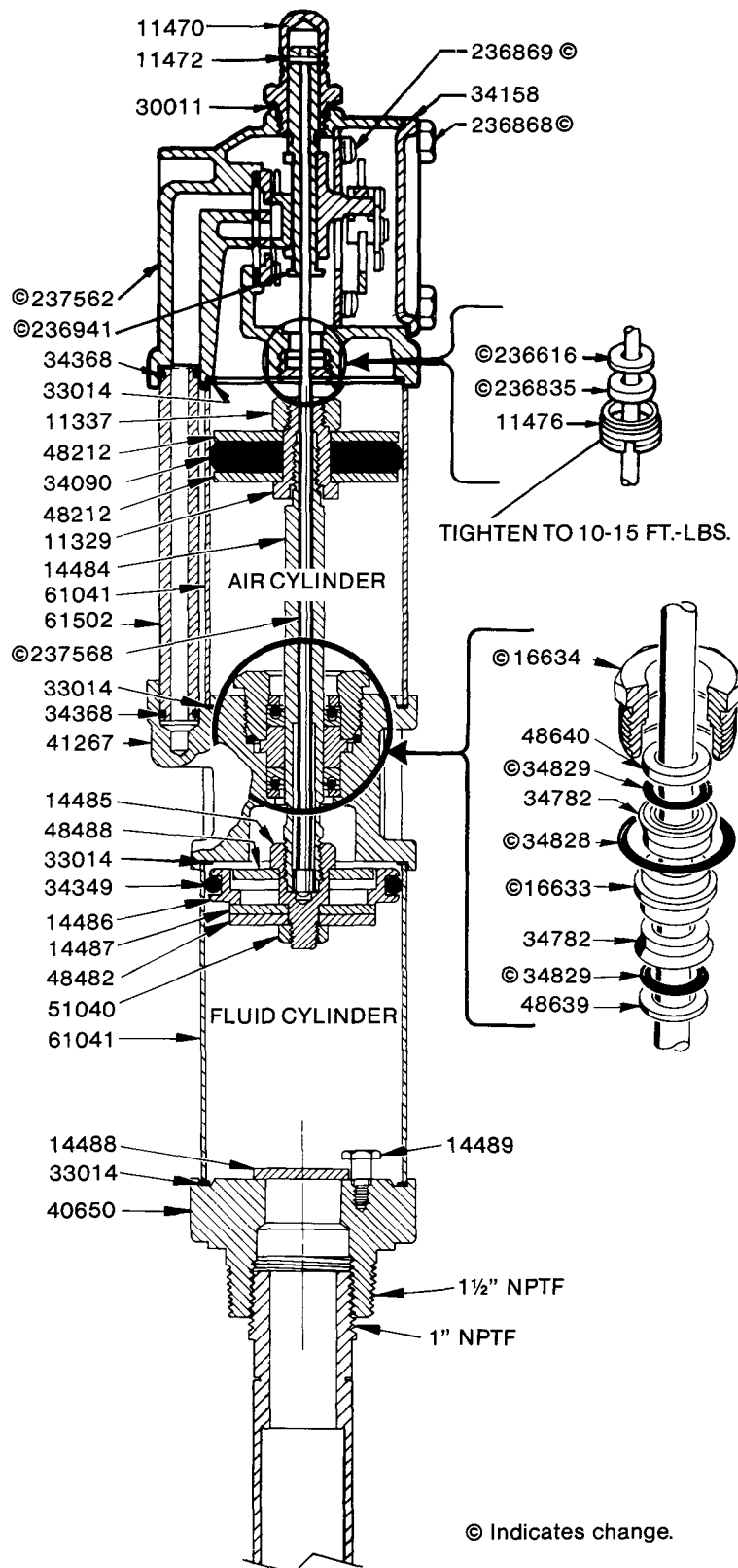

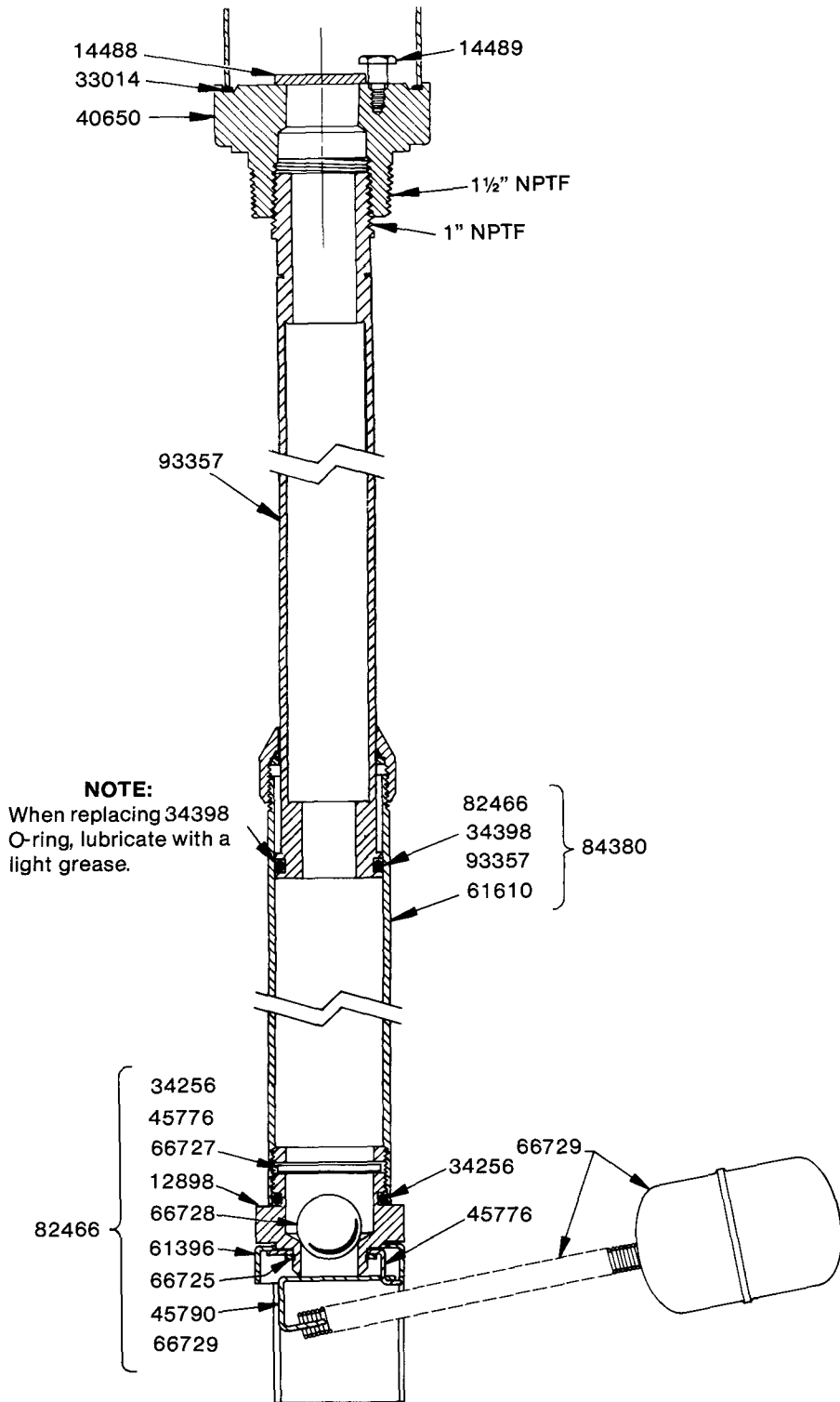

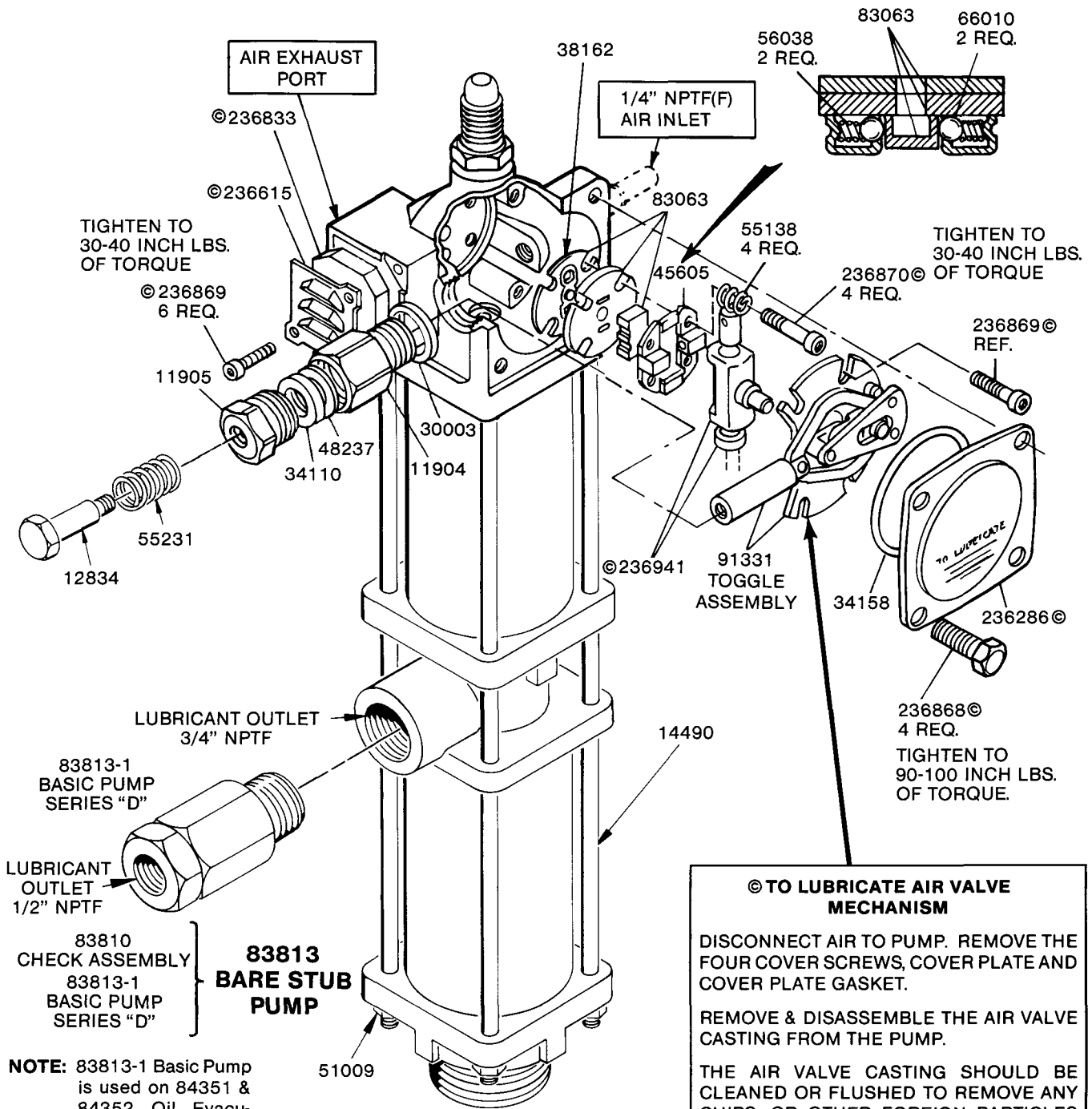

NOTE: 83813-1 Basic Pump is used on 84351 & 84352 Oil Evacuators.

IMPORTANT: Start fasteners by hand to avoid stripping threads when reassembling.

© TO LUBRICATE AIR VALVE MECHANISM

DISCONNECT AIR TO PUMP. REMOVE THE FOUR COVER SCREWS, COVER PLATE AND COVER PLATE GASKET.

REMOVE & DISASSEMBLE THE AIR VALVE CASTING FROM THE PUMP.

THE AIR VALVE CASTING SHOULD BE CLEANED OR FLUSHED TO REMOVE ANY CHIPS, OR OTHER FOREIGN PARTICLES PRIOR TO RE-ASSEMBLY.

BEFORE REPLACING THE TOGGLE ASSEMBLY, PACK CAVITY WITH GREASE.

USE N.L.G.I. No. 1 (LIGHT GRADE) WATER REPELLENT GREASE. APROX. 1½ OUNCES.

REPLACE COVER GASKET, COVER, AND SCREWS. TIGHTEN TO AVOID AIR LEAKS.

PERIODIC INSPECTION OF PARTS AT LEAST ONCE EACH YEAR IS ADVISABLE.

ACCESSORIES
 Filter/regulator & gauge/lubricator.

© Indicates change.

SERVICE PARTS

Part No.	Qty.	Description	Part No.	Qty.	Description
11329	1	Air piston bolt	48212	2	Air piston washer
11337	1	Air piston nut	48237	1	Plunger packing washer
11470	1	Air valve cap	48482	1	Washer
*11472	1	Trip rod pin	48488	1	Star washer
*11476	1	Trip rod packing nut	48639	1	Washer
11904	1	Packing nut	48640	1	Washer
11905	1	Packing cap	51009	4	Tie rod nut
12834	1	Spring retainer	51040	1	Nut
12898	1	Valve body	55138	4	Spring
*14484	1	Piston rod	55231	1	Spring
14485	1	Piston bolt	*56038	2	Spring
14486	1	Pump piston	*61041	2	Air cylinder
14487	1	Piston check	61396	1	Valve tube
14488	1	Check	61502	1	Air passage tube
14489	3	Check retaining screw	61610	1	Tube
14490	4	Tie rod	*66010	2	Ball
16633	1	Gland packing spacer	66725	1	Retaining ring
16634	1	Gland nut	66727	1	Roll pin
*30003	1	Packing nut gasket	*66728	1	Check ball
*30011	1	Valve cap gasket	66729	1	Float & spring arm
*33014	4	Air cylinder gasket	82466	1	Low level cut-off
*34090	1	Air piston packing	83063	1	Valve slide, seat & gasket
*34110	1	Plunger packing	84380	1	Extensible suction tube
*34158	1	Cover gasket	*91331	1	Toggle plate
*34256	1	O-ring	93357	1	Suction tube
*34349	1	Pump piston o-ring	236286	1	Cover
*34368	2	O-ring	236615	1	Muffler cover
*34398	1	O-ring	*236616	1	Trip rod packing gasket
*34782	2	Gland packing	236833	1	Muffler
*34828	1	O-ring	*236835	1	Trip rod packing
*34829	2	O-ring	236868	4	Valve cover screw
*38162	1	Valve seat gasket	236869	6	Toggle plate screw
40650	1	Inlet casting	236870	4	Valve seat bolt
41267	1	Outlet body	236941	1	Trip shoe assembly
45605	1	Valve guide	237562	1	Air valve casting
45776	1	Toggle bracket	*237568	1	Trip rod
45790	1	Valve toggle			

* Recommended service parts inventory.

TROUBLESHOOTING

Problem	Solution
1. Pump does not operate.	Check air supply to pump. Replace 236941 Trip Shoe Assembly and 91331 Toggle Plate.
2. Air seepage from air exhaust port while pump is not operating.	Replace 83063 Valve Slide, Seat & Gasket, 236835 Trip Rod Packing and 236616 Trip Rod Packing Gasket.
3. Loss of pressure, volume or continuous operation of pump when not in normal use.	Clean 82466 Low Level Cut-off. Clean 14488 Check and sealing surface of 40650 Inlet Casting. Clean 14486 Pump Piston, 14487 Piston Check and 48488 Star Washer. Check 34349 Pump Piston O-ring and 61041 Fluid Cylinder. Replace if worn or damaged. Inspect lubricant supply line for leaks or breaks.
4. Excessive amount of air entrapped in lubricant or excessive amount of lubricant coming from air exhaust. Note: Some lubricant exhausts with air normally.	Replace 34782 Gland Packings, 34829 O-rings and 34828 O-ring.

LINCOLN LUBRICATING EQUIPMENT LIMITED WARRANTY

Lincoln, A Pentair Company, warrants that lubrication equipment, materials dispensing equipment and other related equipment manufactured by it will be free from defects in material and workmanship during the one (1) year following the date of purchase. If equipment proves to be defective during this warranty period, it will be repaired or replaced without charge, provided that factory examination indicates the equipment to be defective. To obtain repair or replacement, it must be shipped, transportation charges prepaid, with proof of date of purchase to a Lincoln authorized Warranty and Service Center, within the one (1) year following the date of purchase.

This warranty is extended to the original retail purchaser only. This warranty does not apply to equipment damaged from accident, overload, abuse, misuse, negligence, faulty installation or abrasive or corrosive materials, or to equipment repaired or altered by anyone not authorized by Lincoln to repair or alter the equipment. This warranty applies only to equipment installed and operated according to the recommendations of Lincoln or its authorized field personnel. No other express warranty applies to lubrication equipment, materials dispensing equipment, and other related equipment manufactured by Lincoln.

ANY IMPLIED WARRANTIES applicable to lubrication equipment, materials dispensing equipment, and other related equipment manufactured by Lincoln INCLUDING THE WARRANTIES OF MERCHANTABILITY AND FITNESS FOR A PARTICULAR PURPOSE, WILL LAST ONLY FOR ONE (1) YEAR FROM THE DATE OF PURCHASE. SOME STATES DO NOT ALLOW LIMITATIONS ON HOW LONG AN IMPLIED WARRANTY LASTS, SO THE ABOVE LIMITATION MAY NOT APPLY TO YOU.

In no event shall Lincoln be liable for incidental or consequential damages. The liability of Lincoln on any claim for loss or damage arising out of the sale, resale, or use of lubrication equipment, materials dispensing equipment, and other related equipment shall in no event exceed the purchase price. SOME STATES DO NOT ALLOW THE EXCLUSION OR LIMITATION OF INCIDENTAL OR CONSEQUENTIAL DAMAGES, SO THE ABOVE LIMITATION OR EXCLUSION MAY NOT APPLY TO YOU.

THIS WARRANTY GIVES YOU SPECIFIC LEGAL RIGHTS AND YOU MAY ALSO HAVE OTHER RIGHTS WHICH VARY FROM STATE TO STATE.

————— RETAIN THIS INFORMATION FOR FUTURE REFERENCE —————

When ordering replacement parts, list: Part Number, Description, Model Number, and Series Letter.

LINCOLN provides a Distributor Network that stocks equipment and replacement parts.