

14:1 RATIO, OUTPUT - 1.7 CU. IN./CYL.  
MIN. AIR PRESSURE - 30 PSI  
MAX. AIR PRESSURE - 160 PSI  
MAX. OUTPUT PRESSURE - 2250 PSI

## OWNERS MANUAL

IT IS THE RESPONSIBILITY OF THE OWNER AND/OR OPERATOR TO PROPERLY USE AND MAINTAIN THIS EQUIPMENT. CAREFULLY READ AND UNDERSTAND THE INSTRUCTIONS AND WARNINGS IN THIS MANUAL BEFORE OPERATING THIS EQUIPMENT.

If the operator is not fluent in English, the instructions and warnings shall be read and discussed in the operator's native language, making sure the operator comprehends the contents.

This equipment complies with OSHA Standards where applicable.



### WARNING

**DO NOT** exceed the stated maximum working pressure of the pump or of the lowest rated component in your system.

**DO NOT** alter or modify any part of this equipment.

**DO NOT** operate this equipment with combustible gas.

**DO NOT** attempt to repair or disassemble the equipment while the system is pressurized.

**TIGHTEN** all fluid connections securely before using this equipment.

**ALWAYS** read and follow the fluid manufacturer's recommendations regarding fluid compatibility, and the use of protective clothing and equipment.

**CHECK** all equipment regularly and repair or replace worn or damaged parts immediately.

**IMPORTANT:** Failure to heed these warnings including misuse, overpressurizing, modifying parts, using incompatible chemicals and fluids, or using worn or damaged parts, may result in equipment damage and/or serious personal injury, fire, explosion, or property damage.

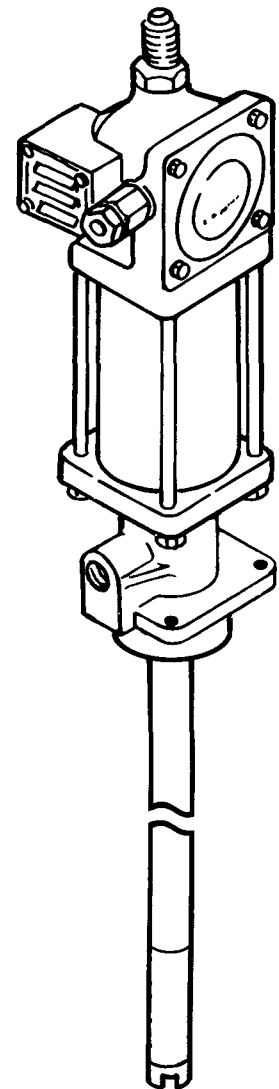

### CONTENTS

### PAGE

Safety Instructions .....	2
Inspection Instructions .....	2
Damaged Pumps .....	2
Installation .....	2
Operation .....	3
Maintenance .....	3
General Dimensions .....	3
Disassembly Procedure .....	4
Parts Breakdown and Accessories .....	4-6
Service Parts .....	7
Troubleshooting Chart .....	7
Warranty .....	8

This manual contains **IMPORTANT WARNINGS** and **INSTRUCTIONS** READ AND RETAIN FOR REFERENCE

## SAFETY INSTRUCTIONS

For professional use only. Observe all warnings. Read and understand all instructions before operating equipment. Extreme caution should be used when operating this equipment as personal injury and/or property damage can result from equipment misuse.

This equipment generates very high fluid pressure. Extreme caution should be used when operating this equipment as material from dispensing valve or leaks from loose or ruptured components can inject fluid through the skin and into the body causing serious bodily injury including possible need for amputation. Adequate protection is recommended to prevent splashing of material onto the skin or into the eyes.

**IMPORTANT:** If any fluid appears to penetrate the skin, get emergency medical care immediately! Do not treat as a simple cut. Tell attending physician exactly what fluid was injected.



### WARNING

**NEVER** point the dispensing valve at any part of the body or at another person.



### WARNING

**NEVER** try to stop or deflect material from dispensing valve or leaking connection or component with your hand or body.



### WARNING

**ALWAYS** check equipment for proper operation before each use, making sure safety devices are in place and operating properly. **DO NOT** alter or modify any part of the equipment as this may cause a malfunction and result in serious bodily injury.



### WARNING

**ALWAYS** follow the pressure relief procedure after shutting off the pump, when checking or servicing any part of the system, and when installing, cleaning or changing any part of the system.



### WARNING

**ALWAYS** read and follow the fluid and solvent manufacturer's recommendations regarding the use of protective clothing and equipment.



### WARNING

#### PRESSURE RELIEF PROCEDURE

To reduce the risk of serious bodily injury, including splashing into the eyes or onto the skin, always follow this procedure: **Whenever you shut off the pump, when checking or servicing any part of the system, and when installing, cleaning or changing any part of the system.**

1. Disconnect air to the pump.
2. Point the dispensing valve away from yourself and others.
3. Open the dispensing valve into an appropriate container until pressure is relieved.

If you suspect that the dispensing valve or hose is completely clogged or that pressure has not been fully relieved after following the above procedure, **VERY SLOWLY** loosen the hose end coupling to relieve pressure gradually, then loosen completely. Now clear the valve or hose.

## INSPECTION INSTRUCTIONS

If overpressurizing of the equipment is believed to have occurred, contact the factory authorized warranty and service center nearest you for inspection of the pump.

Specialized equipment and knowledge is required for repair of this pump. Contact the factory authorized warranty and service center nearest you for repair or adjustments other than maintenance specified in this manual.

Annual inspection by the factory authorized warranty and service center nearest you is recommended.

A list of factory authorized warranty and service centers is available upon request.

## DAMAGED PUMPS

Any pump that appears to be damaged in any way, is badly worn or operates abnormally shall be removed from use until repairs are made. Contact the factory authorized warranty and service center nearest you for repairs.

## INSTALLATION

The typical installation shown is only a guide for selecting and installing system components. Contact your Lincoln representative for assistance in designing a system to suit your specific needs.

An air line filter/regulator/lubricator is recommended for use with your Lincoln pump to remove harmful dirt and moisture from the compressed air supply, and to provide automatic lubrication to the air motor.



### WARNING

This pump can develop 2250 PSI working pressure at 160 PSI maximum incoming air pressure. Be sure that all system equipment and accessories are rated to withstand the maximum working pressure of this pump. **DO NOT** exceed the maximum working pressure of the lowest rated component in the system.

Flush the supply lines and hoses with mineral spirits or oil based solvent and blow dry with air before connecting them to the system. This is to purge any contaminants such as dirt, moisture, or metal shavings that could damage the pump or system components.

The pump was tested in lightweight oil which was left in it to protect the pump from corrosion. Flushing of the pump before connecting it to the system might be desired to prevent contamination of the fluid you are pumping.



### WARNING

To reduce the risk of injury from splashing or static sparking when flushing the pump with mineral spirits or oil based solvent, always hold a metal part of the dispensing valve firmly to the side of a grounded metal pail and operate pump at lowest possible fluid pressure.



## DISASSEMBLY INSTRUCTIONS

1. Remove Valve Cap (11470) and Trip Rod Pin (11472).
2. Unscrew Tie Rod Packing Nuts (51009) from Tie Rods (10294) and lift Air Valve Casting (237562) off of Air Cylinder (61041).
3. Remove Packing Nut (11904) and Packing Cap (11905) from Air Valve Casting.
4. Remove four Screws (236868) and Cover (236286).
5. Remove four Screws (236869), Toggle Plate (91331) and Trip Shoe Assembly (236941).
6. Remove four Screws, (236870), Springs (55138), Valve Guide Plate (45605) and Valve Slide, Seat and Gasket (83063).
7. Unscrew Trip Rod Packing Nut (11476) from Air Valve Casting and remove all packing parts.
8. Unscrew Lower Pump Tube (14371) from Pump Tube.
9. Unscrew Pump Tube Adapter (14374) and Pump Tube from Outlet Body (40579).
10. Place wrenches on Nut (51304) and wrench flats of Pump Piston Rod and unscrew Nut. Remove Piston Check (14375) and Pump Piston (14372).
11. Remove Cotter Pin (68900) and unscrew Pump Piston Rod from Adapter Nipple (14077).
12. Remove Air Cylinder (61041) and Air Passage Tube (61502) from Outlet Body.
13. Extend Piston Rod (14369-9) out bottom of Outlet Body. Place wrenches on Piston Bolt (13300) and on wrench flats of Piston Rod and unscrew Piston Rod. Withdraw Piston from Pump Gland.
14. Unscrew Gland Nut (14090) from Outlet Body and remove all gland parts.
15. To reassemble, reverse procedure. Tighten fasteners per torque specifications supplied. **Important:** To prevent damage to Pump Packings and to help increase Packing Life, Lube Air Cylinder and Piston Rod before assembly.

### Notes:

1. If complete disassembly is required, replace all Gaskets, O-rings and Packings. (Order 83837 Repair Kit.)
2. Before tightening four Valve Seat Screws (236870), align the Valve Slide, Seat and Gasket (83063), Valve Seat Gasket (38162) and Air Valve Casting (237562) by placing a rod or ink pen through the Center Port Hole.
3. Start all fasteners by hand to avoid stripping threads when reassembling.

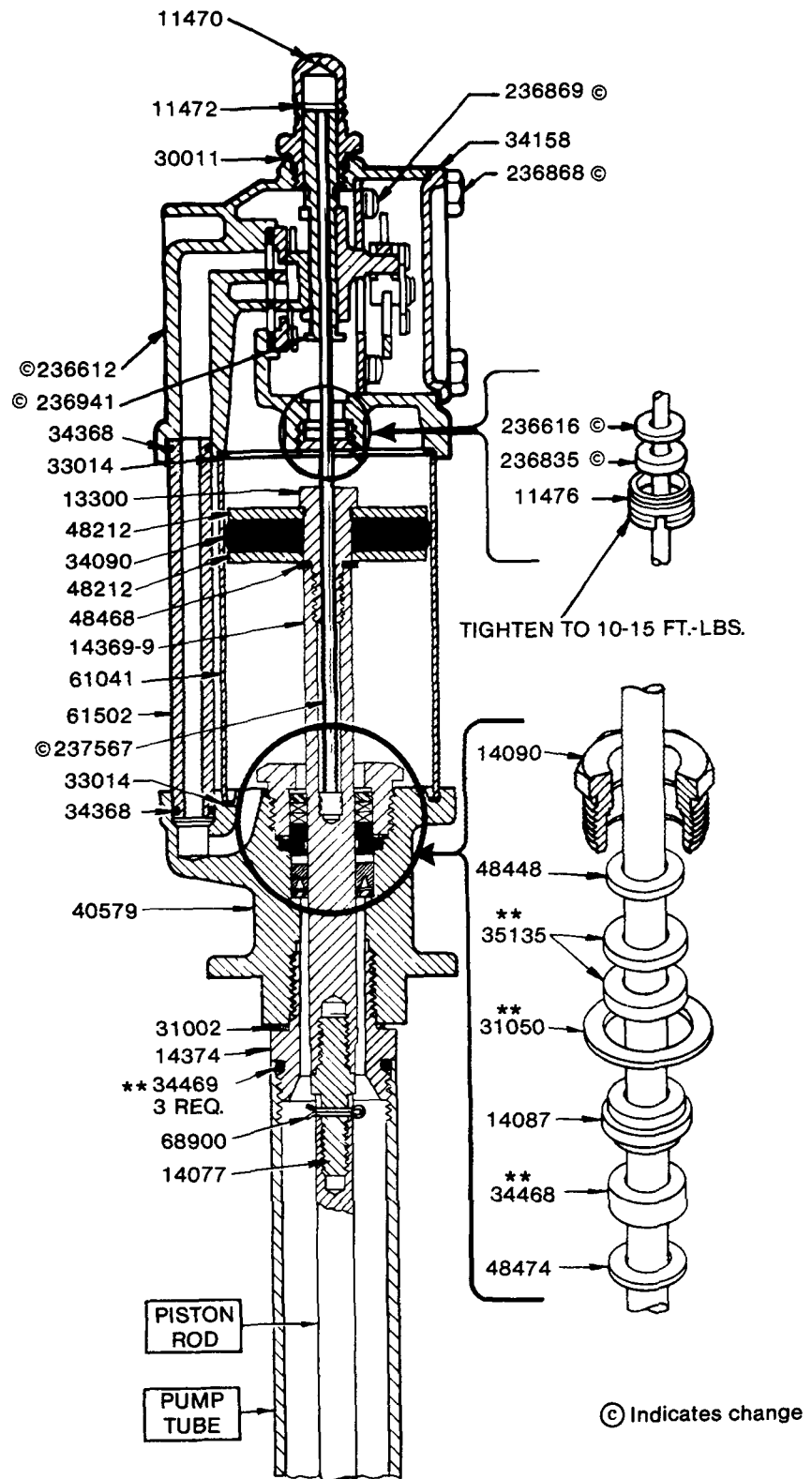
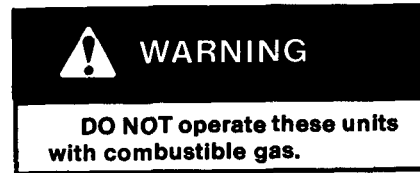

## 2 1/2" AIR MOTOR OPERATED UNDERCOATING PUMPS 14:1 RATIO

\*\* Included in 83837 Repair Kit.

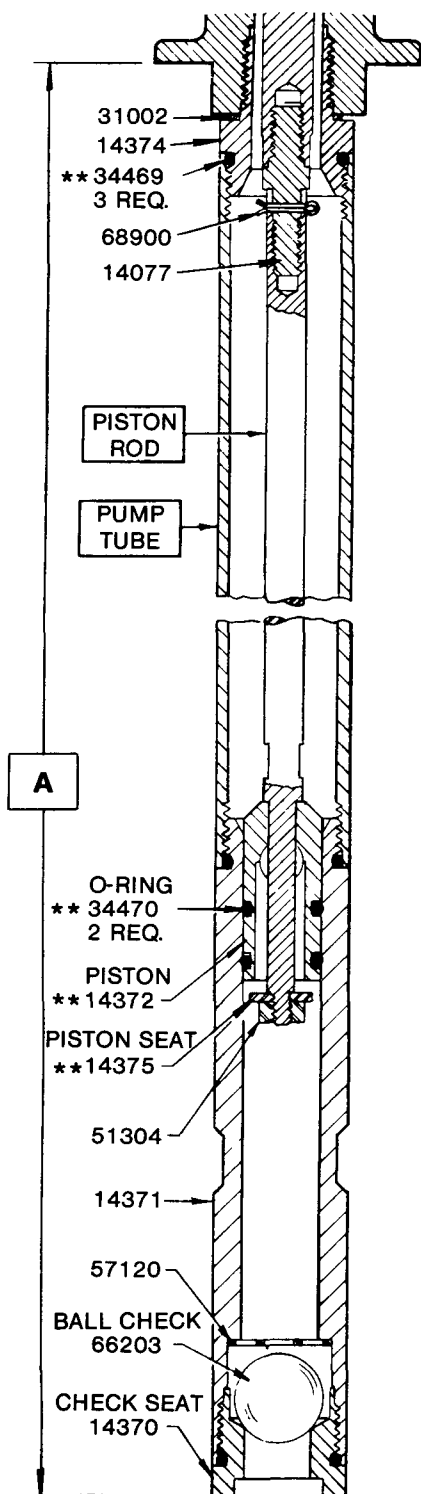

Basic Pump Number	Piston Rod	Pump Tube	Drum Size	Dimension "A"
83737	14373	61522	120 lb.	27-3/8"
83806	14482	61540	400 lb.	33-15/16"
83807	14483	61541	35 lb.	13"

### SERVICE OF LOWER PUMP TUBE ASSEMBLY

Loss of pressure and volume or continuous operation of pump when not in normal use indicates:

1. Undercoating material drum may be empty.
2. Foreign material may be lodged between the Piston (14372) and Check Seat (14375) or between the Ball Check (66203) and Check Seat (14370). Remove parts and clean thoroughly. If sealing surfaces between parts are rough or pitted, replace parts.
3. Material by-passing O-rings (34470), replace O-rings. Inspect inside of pump tube where piston travels. If pump tube is scored or rough, replace pump tube.

### ACCESSORIES

- Filter/regulator & gauge/lubricator.
- Eyebolt kit.
- Follower plate.
- Drum cover.
- 1709 Hoist.

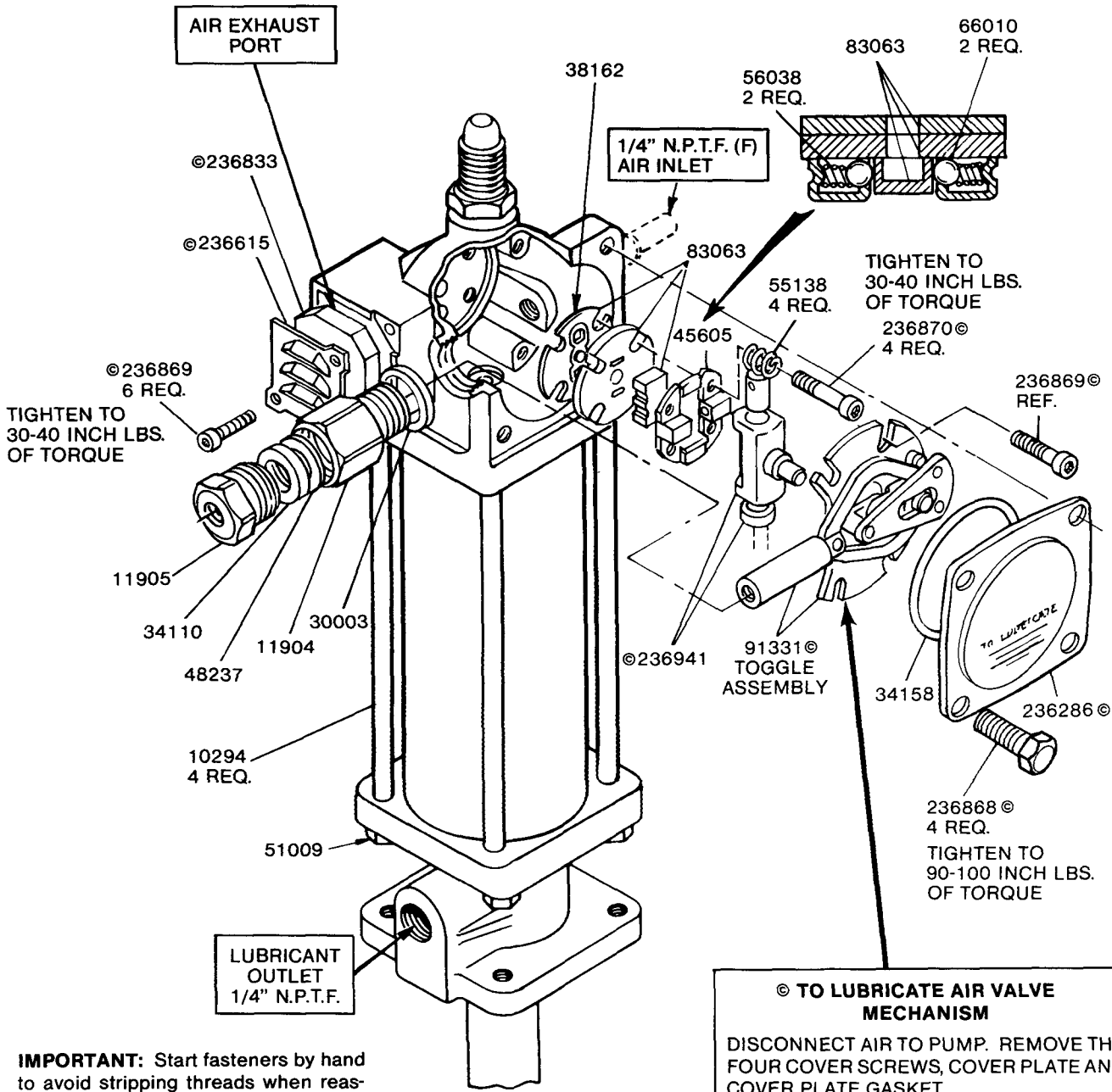

**IMPORTANT:** Start fasteners by hand to avoid stripping threads when re-assembling.

© Indicates change

**© TO LUBRICATE AIR VALVE MECHANISM**

DISCONNECT AIR TO PUMP. REMOVE THE FOUR COVER SCREWS, COVER PLATE AND COVER PLATE GASKET.

REMOVE AND DISASSEMBLE THE AIR VALVE CASTING FROM THE PUMP.

THE AIR VALVE CASTING SHOULD BE CLEANED OR FLUSHED TO REMOVE ANY CHIPS, OR OTHER FOREIGN PARTICLES PRIOR TO RE-ASSEMBLY.

BEFORE REPLACING THE TOGGLE ASSEMBLY, PACK CAVITY WITH GREASE.

USE N.L.G.I. No. 1 (LIGHT GRADE) WATER REPELLENT GREASE. APPROX 1½ OUNCES.

REPLACE COVER GASKET, COVER, AND SCREWS. TIGHTEN TO AVOID AIR LEAKS.

PERIODIC INSPECTION OF PARTS AT LEAST ONCE EACH YEAR IS ADVISABLE.

## SERVICE PARTS

Part	Qty.	Description	Part	Qty.	Description
10294	4	Tie rod	40579	1	Outlet body
11470	1	Valve cap	45605	1	Valve guide
*11472	1	Trip rod pin	48212	2	Air piston washer
*11476	1	Trip rod packing unit	48237	1	Plunger packing washer
11904	1	Packing nut	48448	1	Gland packing washer
11905	1	Packing cap	48468	1	Washer
13300	1	Piston bolt	48474	1	Washer
14077	1	Adapter nipple	51009	4	Nut
14087	1	Gland packing spacer	51304	1	Nut
14090	1	Gland nut	55138	4	Spring
*14369-9	1	Piston rod	*56038	2	Spring
14370	1	Foot valve body	57120	1	Ball check
14371	1	Lower pump tube	*61041	1	Air cylinder
*14372	1	Pump piston	61502	1	Air passage tube
14374	1	Pump tube adapter	*66010	2	Steel ball
14375	1	Piston check	*66203	1	Check ball
*30003	1	Packing nut gasket	68900	1	Cotter pin
*30011	1	Valve cap gasket	83063	1	Valve slide, seat & gasket
*31002	1	Gasket	*91331	1	Toggle plate
*31050	1	Gland gasket	236286	1	Cover
*33014	2	Air cylinder gasket	236615	1	Muffler cover
*34090	1	Air piston packing	*236616	1	Trip rod packing gasket
*34110	1	Plunger packing	236833	1	Muffler
*34158	1	Cover gasket	*236835	1	Trip rod packing
*34368	2	O-ring	236868	4	Screw
*34468	1	U-cup packing	236869	6	Screw
*34469	3	O-ring	236870	4	Valve seat bolt
*34470	2	O-ring	236941	1	Trip shoe assembly
*35135	2	Gland packing	237562	1	Air valve casting
*38162	1	Valve seat gasket	*237567	1	Trip rod

\*Recommended service parts inventory.

## TROUBLESHOOTING

1. Pump does not operate.	<p>Check air supply to pump.</p> <p>Replace Trip Shoe Assembly (236941) and Toggle Plate (991331).</p>
2. Air seepage from air exhaust port while pump is not operating.	<p>Replace Valve Slide, Seat &amp; Gasket (83063), 236835 Trip Rod Packing and Gasket (236616).</p>
3. Loss of pressure, volume or continuous operation of pump when not in normal use.	<p>Clean piston check and ball foot valve.</p> <p>Check Piston (14372), Piston Check (14375) and O-rings (34470). Replace if worn or damaged.</p> <p>Check inside diameter of Lower Pump Tube (14371), replace if scored.</p> <p>Inspect lubricant supply line for leaks or breaks.</p>
4. Excessive amount of air entrapped in lubricant or excessive amount of lubricant coming from air exhaust. <b>Note:</b> Some lubricant exhausts with air normally.	<p>Replace two Gland Packings (35135), Gland Gasket (31050) and U-cup Packing (34468).</p>
5. Pump will not stall against fluid pressure on "Up" stroke.	<p>Replace O-rings (34470).</p> <p>Clean Piston Check (14375) and seating surface of Piston (14372).</p>
6. Pump will not stall against fluid pressure on "Down" stroke.	<p>Clean ball foot valve.</p>

---

## **LINCOLN LUBRICATING EQUIPMENT LIMITED WARRANTY**

Lincoln, A Pentair Company, warrants that lubrication equipment, materials dispensing equipment and other related equipment manufactured by it will be free from defects in material and workmanship during the one (1) year following the date of purchase. If equipment proves to be defective during this warranty period, it will be repaired or replaced without charge, provided that factory examination indicates the equipment to be defective. To obtain repair or replacement, it must be shipped, transportation charges prepaid, with proof of date of purchase to a Lincoln authorized Warranty and Service Center, within the one (1) year following the date of purchase.

This warranty is extended to the original retail purchaser only. This warranty does not apply to equipment damaged from accident, overload, abuse, misuse, negligence, faulty installation or abrasive or corrosive materials, or to equipment repaired or altered by anyone not authorized by Lincoln to repair or alter the equipment. This warranty applies only to equipment installed and operated according to the recommendations of Lincoln or its authorized field personnel. No other express warranty applies to lubrication equipment, materials dispensing equipment, and other related equipment manufactured by Lincoln.

ANY IMPLIED WARRANTIES applicable to lubrication equipment, materials dispensing equipment, and other related equipment manufactured by Lincoln INCLUDING THE WARRANTIES OF MERCHANTABILITY AND FITNESS FOR A PARTICULAR PURPOSE, WILL LAST ONLY FOR ONE (1) YEAR FROM THE DATE OF PURCHASE. SOME STATES DO NOT ALLOW LIMITATIONS ON HOW LONG AN IMPLIED WARRANTY LASTS, SO THE ABOVE LIMITATION MAY NOT APPLY TO YOU.

In no event shall Lincoln be liable for incidental or consequential damages. The liability of Lincoln on any claim for loss or damage arising out of the sale, resale, or use of lubrication equipment, materials dispensing equipment, and other related equipment shall in no event exceed the purchase price. SOME STATES DO NOT ALLOW THE EXCLUSION OR LIMITATION OF INCIDENTAL OR CONSEQUENTIAL DAMAGES, SO THE ABOVE LIMITATION OR EXCLUSION MAY NOT APPLY TO YOU.

THIS WARRANTY GIVES YOU SPECIFIC LEGAL RIGHTS AND YOU MAY ALSO HAVE OTHER RIGHTS WHICH VARY FROM STATE TO STATE.

**———— RETAIN THIS INFORMATION FOR FUTURE REFERENCE ————**

When ordering replacement parts, list: Part Number, Description, Model Number, and Series Letter.

LINCOLN provides a Distributor Network that stocks equipment and replacement parts.