

3:1 RATIO, OUTPUT - 3 GPM  
MIN. AIR PRESSURE - 30 PSI  
MAX. AIR PRESSURE - 200 PSI  
MAX. OUTPUT PRESSURE - 600 PSI

## OWNERS MANUAL

IT IS THE RESPONSIBILITY OF THE OWNER AND/OR OPERATOR TO PROPERLY USE AND MAINTAIN THIS EQUIPMENT. CAREFULLY READ AND UNDERSTAND THE INSTRUCTIONS AND WARNINGS IN THIS MANUAL BEFORE OPERATING THIS EQUIPMENT.

If the operator is not fluent in English, the instructions and warnings shall be read and discussed in the operator's native language, making sure the operator comprehends the contents.

This equipment complies with OSHA Standards where applicable.

### WARNING

**DO NOT** exceed the stated maximum working pressure of the pump or of the lowest rated component in your system.

**DO NOT** alter or modify any part of this equipment.

**DO NOT** operate this equipment with combustible gas.

**DO NOT** attempt to repair or disassemble the equipment while the system is pressurized.

**TIGHTEN** all fluid connections securely before using this equipment.

**ALWAYS** read and follow the fluid manufacturer's recommendations regarding fluid compatibility, and the use of protective clothing and equipment.

**CHECK** all equipment regularly and repair or replace worn or damaged parts immediately.

**IMPORTANT:** Failure to heed these warnings including misuse, overpressurizing, modifying parts, using incompatible chemicals and fluids, or using worn or damaged parts, may result in equipment damage and/or serious personal injury, fire, explosion, or property damage.

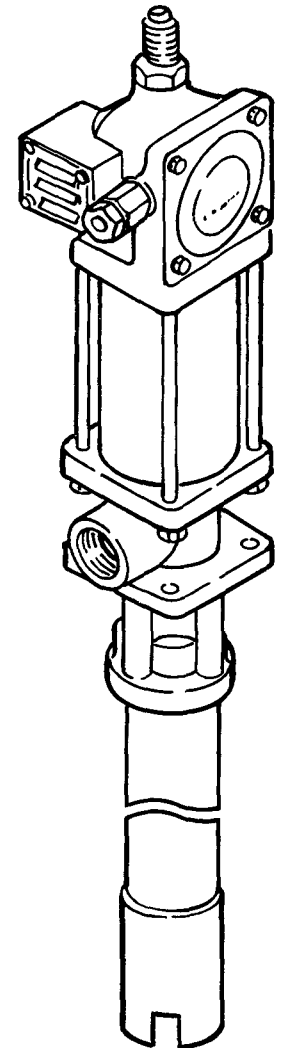

CONTENTS	PAGE
Safety Instructions .....	2
Inspection Instructions .....	2
Damaged Pumps .....	2
Installation .....	2
Operation .....	3
Maintenance .....	3
General Dimensions .....	3
Disassembly Procedure .....	4
Parts Breakdown .....	4-6
Service Parts .....	7
Troubleshooting Chart .....	7
Accessories .....	7
Warranty .....	8

This manual contains **IMPORTANT WARNINGS** and **INSTRUCTIONS** READ AND RETAIN FOR REFERENCE

## SAFETY INSTRUCTIONS

This equipment for professional use only. Observe all warnings. Read and understand all instructions before operating equipment. Extreme caution should be used when operating this equipment as personal injury and/or property damage can result from equipment misuse.



### WARNING

**NEVER** point dispensing valve at any part of the body or at another person.



### WARNING

**NEVER** try to stop or deflect material from dispensing valve or leaking connection or component with your hand or body.



### WARNING

**ALWAYS** check equipment for proper operation before each use, making sure safety devices are in place and operating properly. **DO NOT** alter or modify any part of the equipment as this may cause a malfunction and result in serious bodily injury.



### WARNING

**ALWAYS** follow the pressure relief procedure after shutting off the pump, when checking or servicing any part of the system; and when installing, cleaning or changing any part of the system.



### WARNING

**ALWAYS** read and follow the fluid and solvent manufacturer's recommendations regarding the use of protective clothing and equipment.



## WARNING

### PRESSURE RELIEF PROCEDURE

To reduce the risk of serious bodily injury, including splashing into the eyes or onto the skin, always follows this procedure: Whenever you shut off the pump, when checking or servicing any part of the system, and when installing, cleaning or changing any part of the system.

1. Disconnect air to the pump.
2. Point the dispensing valve away from yourself and others.
3. Open the dispensing valve into an appropriate container until pressure is relieved.

If you suspect that the dispensing valve or hose is completely clogged or that pressure has not been fully relieved after following the above procedure, **VERY SLOWLY** loosen the hose end coupling to relieve pressure gradually, then loosen completely. Now clear the valve or hose.

## INSPECTION INSTRUCTIONS

If overpressurizing of the equipment is believed to have occurred, contact the factory authorized warranty and service center nearest you for inspection of the pump.

Specialized equipment and knowledge is required for repair of this pump. Contact the factory authorized warranty and service center nearest you for repair or adjustments other than maintenance specified in this manual.

Annual inspection by the factory authorized warranty and service center nearest you is recommended.

A list of factory authorized warranty and service centers is available upon request.

## DAMAGED PUMPS

Any pump that appears to be damaged in any way, is badly worn or operates abnormally shall be removed from use until repairs are made. Contact the factory authorized warranty and service center nearest you for repairs.

## INSTALLATION

The typical installation shown is only a guide for selecting and installing system components. Contact your Lincoln Representative for assistance in designing a system to suit your specific needs.

An air line filter/regulator/lubricator is recommended for use with your Lincoln pump to remove harmful dirt and moisture from the compressed air supply, and to provide automatic lubrication to the air motor.



### WARNING

This pump can develop 600 PSI working pressure at 200 PSI maximum incoming air pressure. Be sure that all system equipment and accessories are rated to withstand the maximum working pressure of this pump. **DO NOT** exceed the maximum working pressure of the lowest rated component in the system.

Flush the supply lines and hoses with mineral spirits or oil based solvent and blow dry with air before connecting them to the system. This is to purge any contaminants such as dirt, moisture, or metal shavings that could damage the pump or system components.

The pump was tested in lightweight oil which was left in it to protect the pump from corrosion. Flushing of the pump before connecting it to the system might be desired to prevent possible contamination of the fluid you are pumping.



### WARNING

To reduce the risk of injury from splashing or static sparking when flushing the pump with mineral spirits or oil based solvent, always hold a metal part of the dispensing valve firmly to the side of a grounded metal pail and operate pump at lowest possible fluid pressure.

**OPERATION**

To start the pump, turn on the main air supply. Slowly open the air regulator until the pump runs smoothly. Open the dispensing valve to allow air to be purged from the system. Allow pump to cycle until fluid without air pockets flows from dispensing valve, then close dispensing valve.

In a direct supply system, with adequate air pressure supplied to the air motor, the pump starts when the dispensing valve is opened and stalls against pressure when dispensing valve is closed.

In a circulating system, the pump runs continuously and slows down or speeds up as supply demands until the air supply is shut off.

Use the air regulator to control pump speed and fluid pressure. Always use the lowest pressure required to achieve the desired results. Higher pressures will cause pump packings to wear prematurely.

**WARNING**

To reduce the risk of serious bodily injury or property damage, NEVER exceed the maximum air or fluid working pressure of the lowest rated system component.

If the pump accelerates rapidly or is running too fast, stop it immediately. Check the fluid supply and refill if necessary. Prime the pump to remove all air from the system or flush the pump and relieve pressure.

**WARNING**

Water or even moist air can cause pump to corrode. To help prevent corrosion, NEVER leave the pump filled with water or air. After normal flushing, flush the pump again with mineral spirits or oil based solvent, relieve pressure and leave mineral spirits in the pump. Be sure to follow all steps of the pressure relief procedure warning.

**MAINTENANCE**

**WARNING**

To reduce the risk of serious bodily injury, ALWAYS follow the pressure relief procedure warning whenever you stop the pump and before checking or repairing any part of the system.

**GENERAL DIMENSIONS**

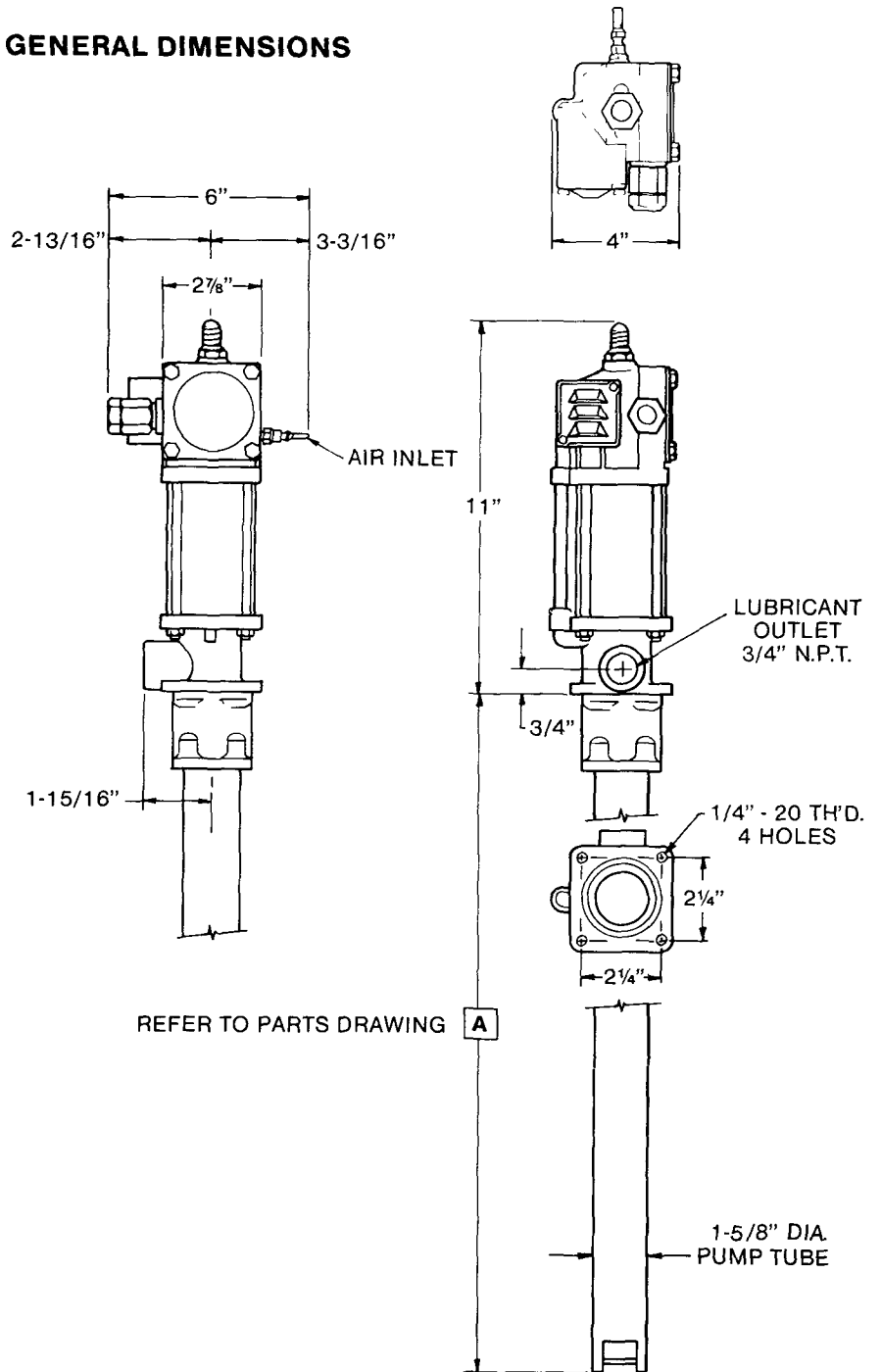

## DISASSEMBLY PROCEDURE

1. Remove Valve Cap(11470) and Trip Rod Pin (11472).
2. Unscrew four Tie Rod Nuts(51009) from Tie Rods (10294) and lift Air Valve Casting (237562) off of Air Cylinder (61041).
3. Remove Packing Nut (11904) and Packing Cap(11905) from Air Valve Casting.
4. Remove four Valve Cover Screws (236868) and Cover (236286).
5. Remove four Toggle Plate Screws (236869), Toggle Plate(91331) and Trip Shoe Assembly (236941).
6. Remove four Valve Seat Bolts (236870), Valve Seat Springs (55138), Valve Guide Plate (45605) and Valve Slide, Seat and Gasket (83063).
7. Unscrew Trip Rod Packing Nut (11476) from Air Valve Casting and remove all packing parts.
8. Unscrew Pump Tube from Outlet Casting (41248).
9. Remove Air Cylinder (61041) and Air Passage Tube (61502) from outlet body.
10. Extend Piston Rod(11340) out bottom of Outlet Casting. Place wrenches on Air Piston Bolt (11329) and on wrench flats on Piston Rod and unscrew Piston Rod. Thread Piston Rod through Gland Packing.
11. Unscrew Gland Packing Nut(12333) from outlet body and remove all gland parts.
12. Unscrew Piston Seat Cap (10943) from Piston Seat (12341) and from Piston Seat Packing (34067), Packing Washer (48140) and Air Expeller Tube (62110).
13. Unscrew Piston Seat (12341) from Piston Rod to allow removal of Piston (12338), Spring Stop (12337) and Spring (55195).
14. To reassemble, reverse procedure. Tighten fasteners per torque specifications provided.

**IMPORTANT:** To prevent damage to Air Piston Packing and Pump Gland Packing, and to help increase packing life, Lube Air Cylinder and Air Piston Rod before assembly. Thread Piston Rod through Gland Packing when assembling pump.

### NOTES:

1. If complete disassembly is required, replace all gaskets, o-rings and packings. (Order 83060 Repair Kit.)
2. Before tightening four Valve Seat Bolt (236870), align the Valve Slide, Seat and Gasket Plate (83063), Slide Valve Gasket (38162) and Air Valve Casting (237562) by placing a rod or ink pen through the center port hole.
3. Start all fasteners by hand to avoid stripping threads when reassembling.

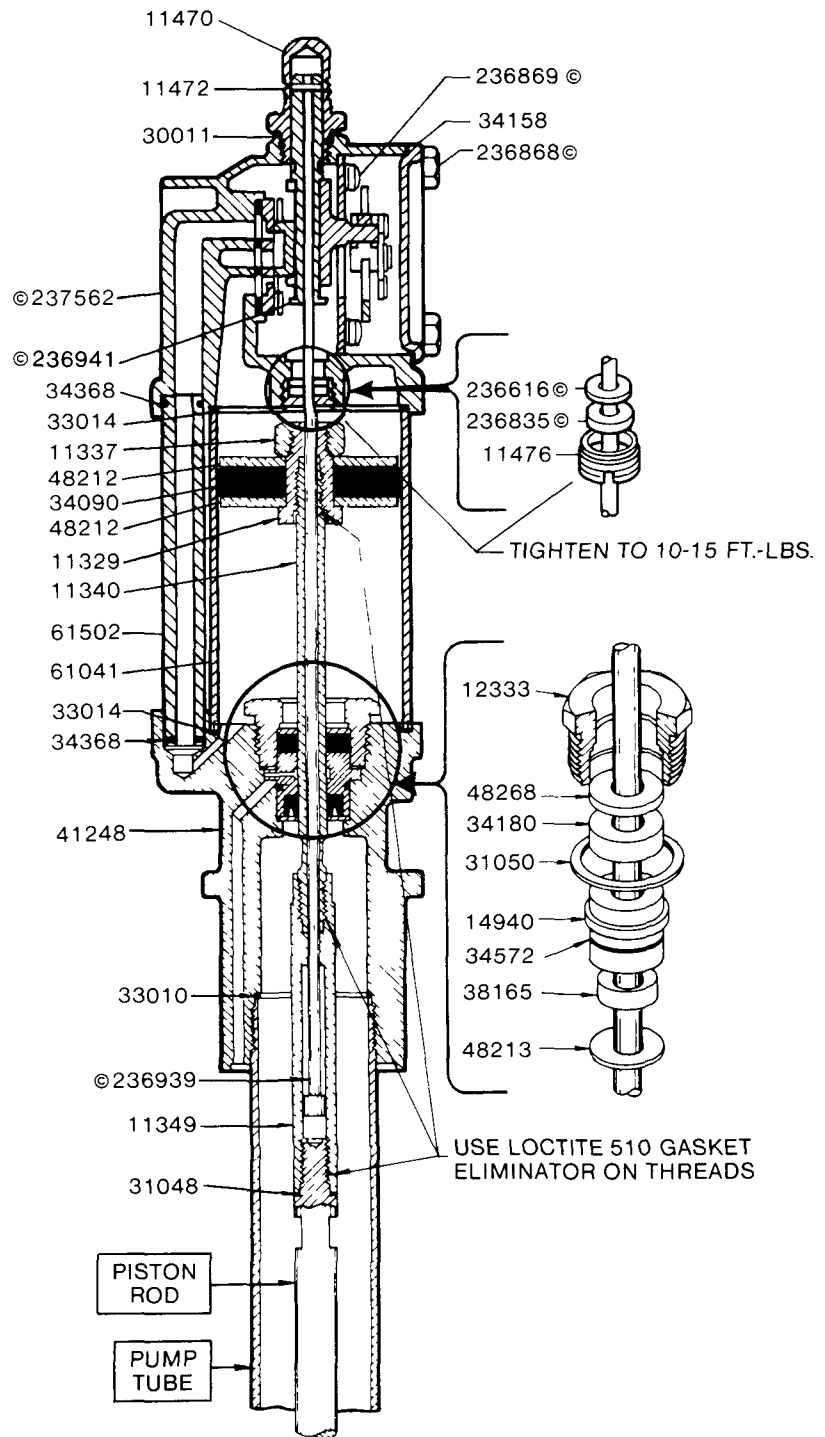

© Indicates change

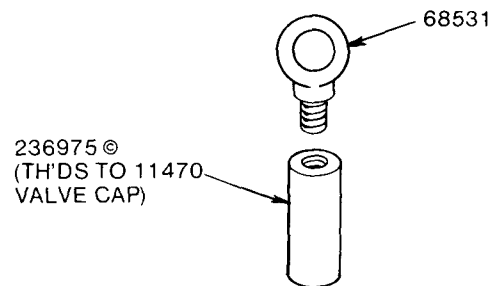
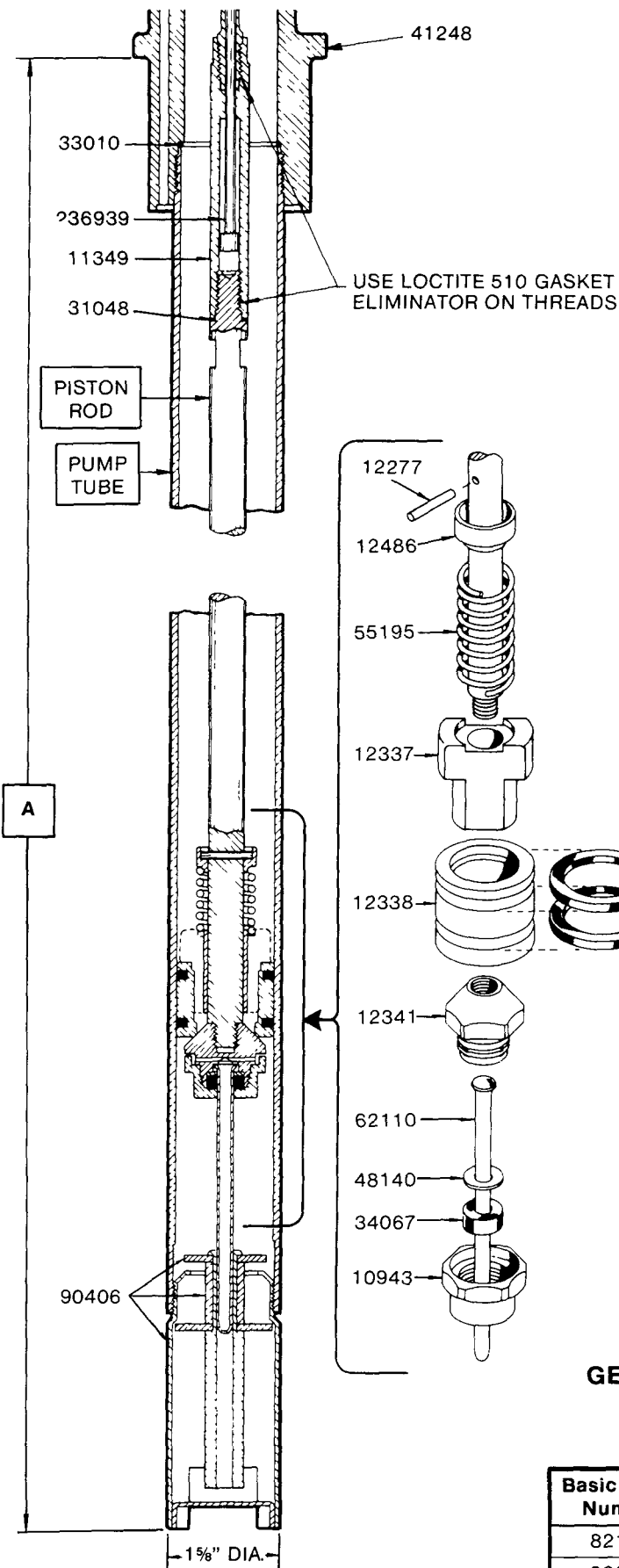

**EYEBOLT KIT**  
 FOR HOISTING PURPOSES (OPTIONAL)  
 (PARTS MUST BE ORDERED SEPARATELY)

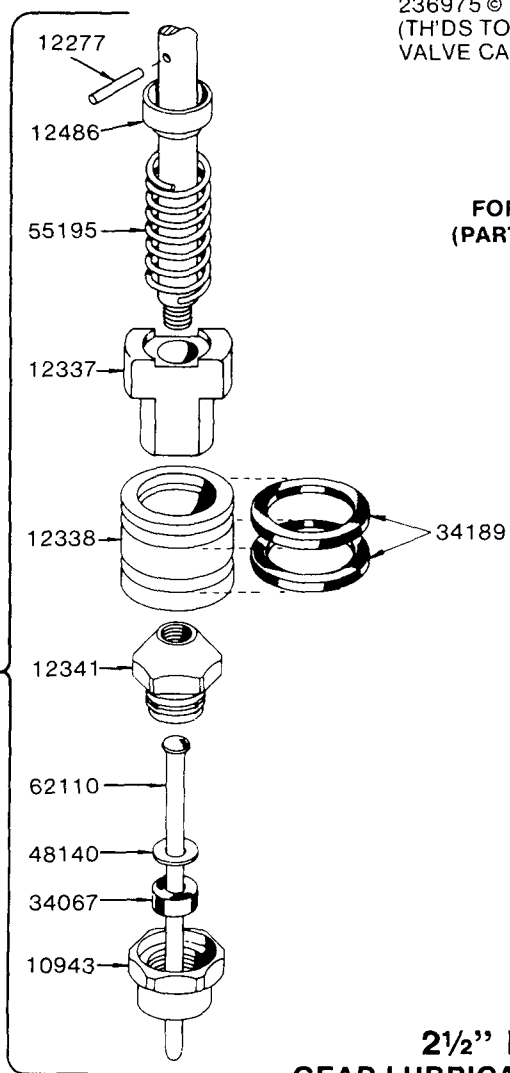

**2 1/2" DIA. AIR MOTOR**  
**GEAR LUBRICANT LOW PRESSURE PUMPS**  
**3:1 RATIO**

Basic Pump Number	Piston Rod	Pump Tube	Drum Size	Dimension "A"	Pump Series
82133	12342	61341	400 lb.	36-5/16"	L
82686	13021	61422	120 lb.	27-6/16"	F
84166	14951	61569	275 gal. tank	43-5/16"	C

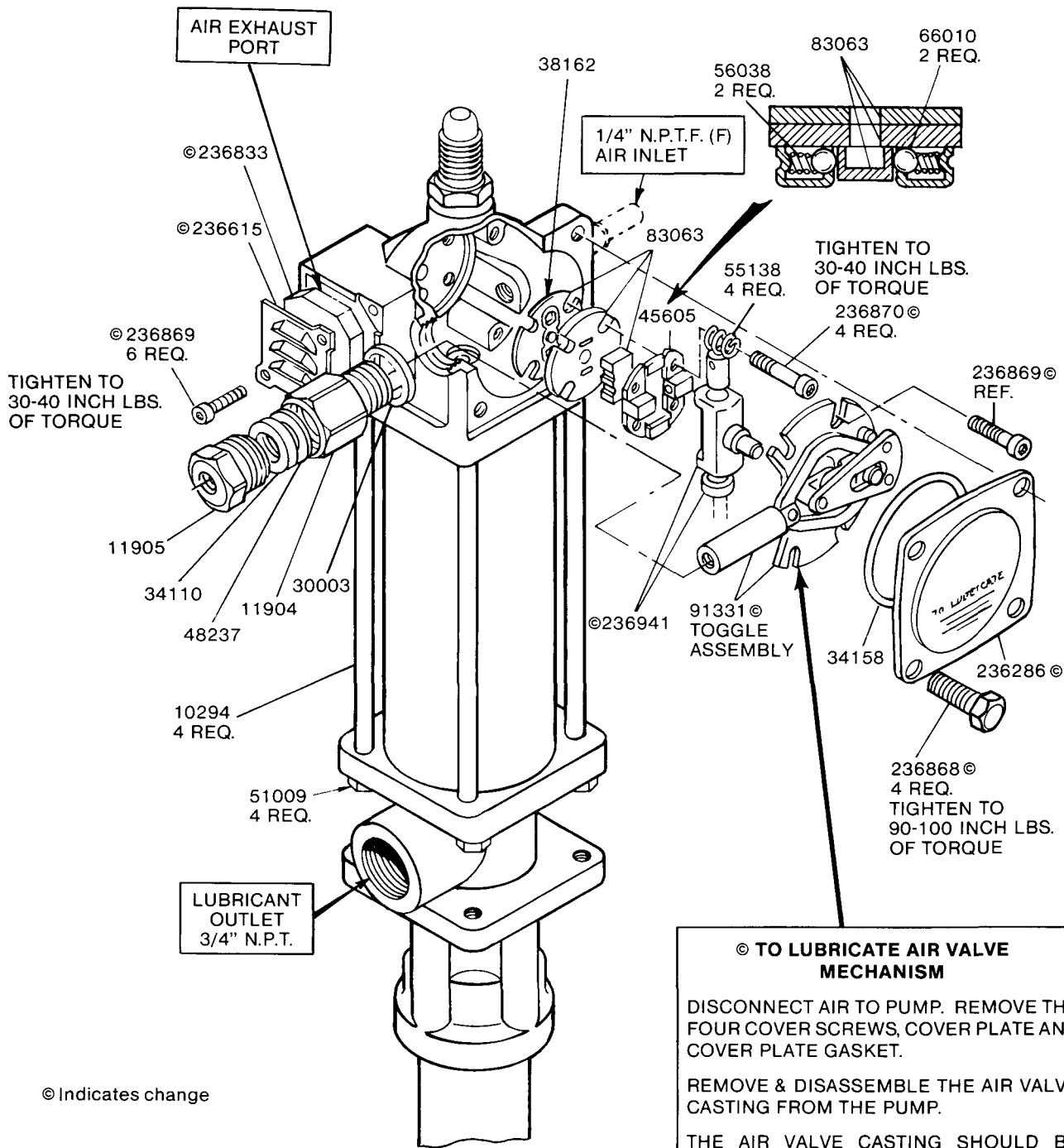

TIGHTEN TO 30-40 INCH LBS. OF TORQUE

TIGHTEN TO 30-40 INCH LBS. OF TORQUE

TIGHTEN TO 90-100 INCH LBS. OF TORQUE

**© TO LUBRICATE AIR VALVE MECHANISM**

DISCONNECT AIR TO PUMP. REMOVE THE FOUR COVER SCREWS, COVER PLATE AND COVER PLATE GASKET.

REMOVE & DISASSEMBLE THE AIR VALVE CASTING FROM THE PUMP.

THE AIR VALVE CASTING SHOULD BE CLEANED OR FLUSHED TO REMOVE ANY CHIPS, OR OTHER FOREIGN PARTICLES PRIOR TO RE-ASSEMBLY.

BEFORE REPLACING THE TOGGLE ASSEMBLY, PACK CAVITY WITH GREASE.

USE N.L.G.I. No. 1 (LIGHT GRADE) WATER REPELLENT GREASE. APPROX. 1½ OUNCES.

REPLACE COVER GASKET, COVER, AND SCREWS. TIGHTEN TO AVOID AIR LEAKS.

PERIODIC INSPECTION OF PARTS AT LEAST ONCE EACH YEAR IS ADVISABLE.

© Indicates change

© **IMPORTANT**—START FASTENERS BY HAND TO AVOID STRIPPING THREADS WHEN RE-ASSEMBLING

## SERVICE PARTS

Part	Qty.	Description	Part	Qty.	Description
10294	4	Tie rod	*38165	1	U-cup packing
10943	1	Piston seat cap	41248	1	Outlet casting
11329	1	Air piston bolt	45605	1	Valve guide plate
11337	1	Air piston nut	48140	1	Packing washer
*11340	1	Air motor piston rod	48212	2	Air piston washer
11349	1	Piston rod connector	48213	1	Gland packing washer
11470	1	Valve cap	48237	1	Plunger packing washer
*11472	1	Trip rod pin	48268	1	Gland packing washer
11476	1	Trip rod packing nut	51009	4	Tie rod nut
11904	1	Packing nut	*55138	4	Valve seat spring
11905	1	Packing cap	*55195	1	Spring
12277	1	Pin	*56038	2	Spring
12333	1	Gland packing nut	*61041	1	Air cylinder
12337	1	Spring stop	61502	1	Air passage tube
*12338	1	Piston	62110	1	Air expeller tube
12341	1	Piston seat	*66010	4	Check ball
12486	1	Pin retainer	68531	1	Eye bolt
14940	1	Gland packing spacer	*83063	1	Valve slide, seat & gasket
*30003	1	Packing nut gasket	90406	1	Foot valve
*30011	1	Valve cap gasket	*91331	1	Toggle plate
*31048	1	Connector gasket	236286	1	Cover
*31050	1	Gland gasket	236615	1	Muffler cover
*33010	1	Pump tube gasket	*236616	1	Packing nut gasket
*33014	2	Air cylinder gasket	236833	1	Muffler packing
*34067	1	Piston seat packing	*236835	1	Trip rod packing
*34090	1	Air piston packing	236868	4	Valve cover screw
*34110	1	Plunger packing	*236869	6	Toggle plate screw
*34158	1	Cover gasket	236870	4	Valve seat bolt
*34180	1	Gland packing	*236939	1	Trip rod
*34189	2	Piston packing	236941	1	Trip shoe assembly
*34368	2	O-ring	236975	1	Extension adapter
*34572	1	O-ring	237562	1	Air valve casting
*38162	1	Slide valve gasket			

\* Recommended service parts inventory.

## TROUBLESHOOTING

Problem	Solution
1. Pump does not operate.	Check air supply to pump. Replace 236941 Trip Shoe Assembly and 91331 Toggle Plate.
2. Air seepage from air exhaust port while pump is not operating.	Replace 83063 Valve Slide, Seat & Gasket, 236835 Trip Rod Packing and 236616 Gasket.
3. Loss of pressure, volume, or continuous operation of pump when not in normal use.	Remove and clean piston, piston seat and foot valve. Inspect 12238 Piston, 12341 Piston Seat and 34189 Piston Packings. Replace if worn or damaged. Inspect fluid supply line for leaks or breaks.
4. Excessive amount of air entrapped in fluid or excessive amount of fluid coming from air exhaust <b>Note:</b> Some fluid exhausts with air normally.	Replace 34180 Gland Packing, 31050 Gland Gasket, 34572 O-ring and 38165 U-cup Packings.

### ACCESSORIES

Filter/Regulator & Gauge/Lubricator

Drum Cover 120 Lb., 400 Lb.

Eyebolt Kit

Bung Bushing (2" NPTF)

1709 Hoist

---

## **LINCOLN LUBRICATING EQUIPMENT LIMITED WARRANTY**

Lincoln, A Pentair Company, warrants that lubrication equipment, materials dispensing equipment and other related equipment manufactured by it will be free from defects in material and workmanship during the one (1) year following the date of purchase. If equipment proves to be defective during this warranty period, it will be repaired or replaced without charge, provided that factory examination indicates the equipment to be defective. To obtain repair or replacement, it must be shipped, transportation charges prepaid, with proof of date of purchase to a Lincoln authorized Warranty and Service Center, within the one (1) year following the date of purchase.

This warranty is extended to the original retail purchaser only. This warranty does not apply to equipment damaged from accident, overload, abuse, misuse, negligence, faulty installation or abrasive or corrosive materials, or to equipment repaired or altered by anyone not authorized by Lincoln to repair or alter the equipment. This warranty applies only to equipment installed and operated according to the recommendations of Lincoln or its authorized field personnel. No other express warranty applies to lubrication equipment, materials dispensing equipment, and other related equipment manufactured by Lincoln.

ANY IMPLIED WARRANTIES applicable to lubrication equipment, materials dispensing equipment, and other related equipment manufactured by Lincoln INCLUDING THE WARRANTIES OF MERCHANTABILITY AND FITNESS FOR A PARTICULAR PURPOSE, WILL LAST ONLY FOR ONE (1) YEAR FROM THE DATE OF PURCHASE. SOME STATES DO NOT ALLOW LIMITATIONS ON HOW LONG AN IMPLIED WARRANTY LASTS, SO THE ABOVE LIMITATION MAY NOT APPLY TO YOU.

In no event shall Lincoln be liable for incidental or consequential damages. The liability of Lincoln on any claim for loss or damage arising out of the sale, resale, or use of lubrication equipment, materials dispensing equipment, and other related equipment shall in no event exceed the purchase price. SOME STATES DO NOT ALLOW THE EXCLUSION OR LIMITATION OF INCIDENTAL OR CONSEQUENTIAL DAMAGES, SO THE ABOVE LIMITATION OR EXCLUSION MAY NOT APPLY TO YOU.

THIS WARRANTY GIVES YOU SPECIFIC LEGAL RIGHTS AND YOU MAY ALSO HAVE OTHER RIGHTS WHICH VARY FROM STATE TO STATE.

**————— RETAIN THIS INFORMATION FOR FUTURE REFERENCE —————**

When ordering replacement parts, list: Part Number, Description, Model Number, and Series Letter.

LINCOLN provides a Distributor Network that stocks equipment and replacement parts.